

Technical Handbook



IMPORTANT

Holo-Krome has published this handbook as a guide to dimensional, mechanical, and application data for Holo-Krome Socket Screw Products. However, the following limitations must be carefully observed in using the information presented in this handbook:

- (1) The data in this handbook is subject to change from time to time as a result of changes in products and specifications. To obtain the latest technical data pertaining to Holo-Krome products, contact the Holo-Krome Engineering Department.
- (2) Certain products listed in these tables are non-stock products. Specifications of non-stock products may differ slightly from the handbook description, due to differences in the manufacturing process.
- (3) Proper screw sizes and tightening torque for any given application is a function of the various design parameters, such as heat, lubrication, etc. Therefore, the data in this handbook should be used only for general guidance in conjunction with the specific design criteria and with the application of proper engineering principles.
- (4) Holo-Krome disclaims all responsibility for its products if they are modified in any way, including plating, hardness alterations, drilling, etc. Specials will be quoted complete by Holo-Krome on request.
- (5) Appropriate specifications are shown with the applicable products. Many of these are written by consensus organizations, and, while Holo-Krome intends that its standard products meet these specifications in all respects, there are changes which take place over the years and must be considered not applicable on a retroactive basis.
- (6) This handbook has been revised to provide data for Metric module products as well as those in Inch module. The organization of the book is designed to make it easy for the user to find his information in whatever module he is working. The Dimensional Data in each case is presented for the various products, followed by the Application Data. Inch module is presented complete, followed by the Metric.

The Holo-Krome Engineering Department welcomes questions regarding fasteners for specific customer applications. Their technical experience and special test facilities in the precision fasteners field are available to help solve your fastener problems.

THE HOLO-KROME QUALITY STORY

Quality is frequently defined as conformance to specification, and at Holo-Krome a great deal of effort is expended in ensuring that the products shipped do, in fact, meet the required specification.

From the placing of the raw material order, through the shipping and certification of the finished product, Holo-Krome procedures and specifications are applied to meet that objective.

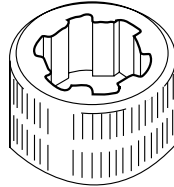

The definition of the required specification requires a little discussion. Holo-Krome's products, like those of any manufacturer, must meet certain criteria. The definition of those criteria can be done several ways. It is common for people to refer to an "Industry Standard," when they are looking for an easy way to define a product. Actually, any manufactured article must, of necessity, have two sets of characteristics: the dimensional, controlling the size and shape, and the mechanical, controlling the base material and the performance of the product. In the fastener industry, there are many organizations which write standards or

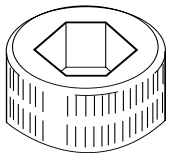

specifications for this product. In the case of socket head cap screws, for instance, one set of applicable standards would be the ASME/ANSI B18.3, which defines the dimensional characteristics of this product, and

ASTM A574, which defines the mechanical properties. Both of these are quite detailed, providing on the one hand, basic size definitions such as diameter, length and thread size, as well as surface finish, concentricity and method of manufacture, and, on the other hand the basic chemistry, heat treatment, hardness, tensile strength and other metallurgical characteristics, as well as the tests necessary to establish they have been done correctly.

Holo-Krome's specification for raw material has been designed to provide material which will properly make the desired product, without inherent flaws that might be harmful. When the material is received, it is inspected to be sure that it does meet those specifications, and then a Lab Number is assigned, which will provide traceability throughout manufacturing, testing, storage and shipment.

From the first set-up on the first machine, calibrated gages and control charts are used to ensure conformance to the prints which have been assigned, and at heat treatment, utilizing atmosphere-controlled furnaces, testing is performed to the further corroborate adherence to specification. In the case of special products, the customer may request other specifications to meet his own particular needs. There are many specifications in existence for the type of product we are discussing, and the selection of these specifications is a matter of agreement between purchaser and seller. In most cases, the "Industry Standard" is used, which is the combination shown above, for socket head cap screws.

The ingredient necessary to provide all of these assurances lies in Holo-Krome's people, who are trained in the various arts and skills needed to perform the checks and tests required. In addition to these people and their skills is the physical plant and equipment which they use. From indicating thread gages of the latest type, and laser measuring equipment, to automated devices to create metallographic specimens, as well as appropriate testing equipment, the investment has been made to have available whatever is required for assurance that the specifications are being met.

This devotion to quality is a company philosophy, from top management to the last packer on the line. Quality is everybody's job, and every associate in the Holo-Krome organization is aware of that fact, and very much a part of it. Associate Involvement Groups are used in the plant to help solve problems which are broader in scope than a single machine, and these have proven to be successful in the drive for continuous improvement which is the Holo-Krome philosophy.

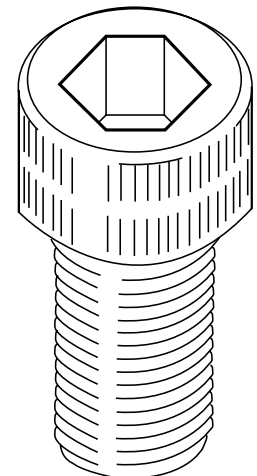

INCH FASTENERS

TABLE OF CONTENTS

DIMENSIONAL DATA	Page No.
Socket Head Cap Screws-1960 Series	1-6
Sems for Socket Head Cap Screws	7-8
Low Head Cap Screws	9
Flat Countersunk Head Cap Screws	10,11
Button Head Cap Screws	12
Hexagon and Spline Sockets	13
Socket Head Shoulder Screws	14,15
Set Screws	16-18
Dowel Pins and Pull Dowel Pins	19
Allen Wrenches and Bits	20
Allen Spline Keys and Bits	21
Socket Pressure Plugs-Dryseal-(NPTF)-3/4 Taper	22
Socket Pressure Plugs-Flush-(PTF)-7/8 Taper	23
Socket Jam Screws	24
Allenuts	24
Holo-Krome Thread Standards and Radius Root Dimensions	25
Holo-Krome Finishes	26
Galvanic Corrosion	26
Thermal Expansion	26
 MECHANICAL PROPERTIES AND APPLICATIONS DATA	 27
Mechanical Properties and Applications Data	28
Comparison-Socket Screws and Hex Head Screws	29
Applications of Various Head Styles	30
Mechanical Properties-Socket Head Cap Screws-1960 Series	31
Torque Data-Socket Head Cap Screws-1960 Series	32
Decarburization and Discontinuity Limits	33
Mechanical Properties-Stainless Steel Socket Head Cap Screws	34
Mechanical Properties-Button Head, Flat Countersunk Head, Low Head Cap Screws	35
Tightening Torque-Button Head, Flat Countersunk Head, Low Head Cap Screws	35
Mechanical Properties-Socket Shoulder Screws	36
Socket Set Screws-Alloy Steel-Application Data	37
Socket Set Screws-Axial Holding Power	38,39
Mechanical Properties-Allen Wrenches and Bits	40
Application Data-Socket Pressure Plugs	41
Coated Pressure Plugs	42
Mechanical Properties-Dowel Pins	43
Holo-Krome Nylok Hex-Socket Screws	44,45
Fastener Related Standards	46,47
General Application Data-Index	48
Glossary of Terms	49,50
Tapping Hints	51
Tap Drill/Hole Sizes	51
Fastener Joint Design	52
Fastener Strengths	53
Metric Conversions	54
Hardness Value Conversions	55
Effects of Alloying Elements	56
Metric Socket Fasteners	57

Inch Section

INDEX TO TABLES

	Page No.
Table 1	Holo-Krome Socket Head Cap Screws-Dimensions 1960 series 1
Table 1A	Dimensions of Underhead Fillets 2
Table 2	Holo-Krome Socket Head Cap Screws- Body and Grip Lengths 3
Table 3	Holo-Krome Socket Head Cap Screws-Functional Limits for Runout of Head, Body and Thread 4
Table 4	Dimensions for Drilled-Head Socket Screws 5
Table 5	Drill and Counterbore Sizes - Socket Head Cap Screws-1960 Series 6
Table 6	Dimensions of Helical Spring Lock Washers for Socket Head Cap Screw Sems 7
Table 6A	Dimensions of Plain Washers for Sems 8
Table 6B	Dimensions of Conical Spring Washers for Sems 8
Table 7	Holo-Krome Socket Low Head Cap Screws-Dimensions 9
Table 8	Holo-Krome Socket Flat Countersunk Head Cap Screws-Dimensions 10
Table 9	Holo-Krome Socket Flat Countersunk Head Cap Screws-Body and Grip Lengths 11
Table 9A	Holo-Krome Socket Flat Countersunk Head Cap Screws-(Beyond sizes in Table 9) 11
Table 10	Holo-Krome Socket Button Head Cap Screws-Dimensions 12
Table 11	Holo-Krome Hexagon and Spline Sockets-Dimensions 13
Table 12	Holo-Krome Socket Head Shoulder Screws-Dimensions 14
Table 13	Holo-Krome Socket Set Screws-Dimensions 16,17
Table 14	Holo-Krome Socket Set Screws-Key Engagements for Short Length Set Screws 18
Table 15	Holo-Krome Dowel Pins-Dimensions 19
Table 16	Holo-Krome Pull Dowel Pins-Dimensions 19
Table 17	Allen Wrenches and Bits-Dimensions 20
Table 18	Allen Spline Keys and Bits-Dimensions 21
Table 19	Holo-Krome Socket Pressure Plugs-Dryseal (NPTF) Type-3/4 Taper-Dimensions 22
Table 20	Holo-Krome Socket Pressure Plugs-Flush (PTF) Type-7/8 Taper-Dimensions 23
Table 21	Holo-Krome Socket Jam Screws-Dimensions 24
Table 22	Allenuts-Dimensions 24
Table 23	Holo-Krome Thread Standards 25
Table 24	Holo-Krome Finishes 26
Table 24A	Galvanic Corrosion 26
Table 24B	Thermal Expansion 26
Table 25	Holo-Krome Socket Head Cap Screws Series Mechanical Properties-1960 Series 31
Table 26	Holo-Krome Socket Head Cap Screws-Torque Data-1960 Series 32
Table 27	Decarburization and Discontinuity Limits 33
Table 28	Holo-Krome Stainless Steel Socket Head Cap Screws 34
Table 29	Holo-Krome Button, Flat Countersunk Cap Screws-Mechanical Properties & Tightening Torque ... 35
Table 29A	Holo-Krome Low Head Socket Cap Screws-Mechanical Properties & Tightening Torque 35
Table 30	Holo-Krome Socket Shoulder Screws-Mechanical Properties 36
Table 31	Holo-Krome Socket Set Screws-Axial Holding Power 38
Table 32	Holo-Krome Allen Wrenches and Bits-Mechanical Properties & Application Data 40
Table 33	Holo-Krome Pressure Plugs-Application Data 41
Table 34	Holo-Krome Dowel Pins-Mechanical Properties 43
Table 35	Fastener Related Standards 46,47
Table A-1	Common Tap Drill Sizes-Inch & Metric 51
Table A-2	Fastener Strengths 53
Table A-3	Conversion Table-Fractional Inch to Decimal Inch and Millimeter 54
Table A-4	Conversion Table-Millimeters to Inches 54
Table A-5	Decimal Equivalent-Drill Sizes 54
Table A-6	Hardness Value Conversions 55

Intentionally Left Blank

TABLE 1 HOLO-KROME SOCKET HEAD CAP SCREWS—1960 SERIES

**HOLO-KROME
THERMO-FORGED®
GRAIN FLOW**

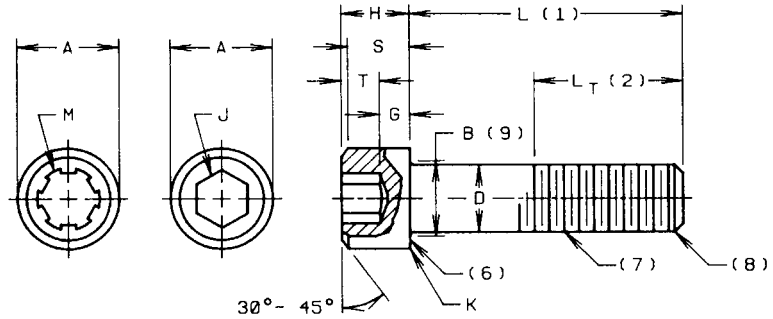

TABLE 1 DIMENSIONS—1960 SERIES

NOMINAL SIZE	BASIC SCREW DIAMETER	D(3) BODY DIAMETER		A(4) HEAD DIAMETER		H HEAD HEIGHT		S HEAD SIDE HEIGHT	M(5) SPLINE SOCKET SIZE	J(5) HEXAGON SOCKET SIZE	T KEY ENGAGEMENT	G WALL THICKNESS	K CHAMFER OR RADIUS	L _{T(2)} THREAD LENGTH		
		MAX.	MIN.	MAX.	MIN.	MAX.	MIN.	MIN.	NOM.	NOM.	MIN.	MIN.	MAX.	MAX.	MIN.	
		0	0.0600	0.0600	0.0568	0.096	0.091	0.060	0.057	0.054	0.060	0.050	0.025	0.020	0.003	0.62
1	0.0730	0.0730	0.0695	0.118	0.112	0.073	0.070	0.066	0.072	1/16	0.062	0.031	0.025	0.003	0.77	0.62
2	0.0860	0.0860	0.0822	0.140	0.134	0.086	0.083	0.077	0.096	5/64	0.078	0.038	0.029	0.003	0.80	0.62
3	0.0990	0.0990	0.0949	0.161	0.154	0.099	0.095	0.089	0.096	5/64	0.078	0.044	0.034	0.003	0.83	0.62
4	0.1120	0.1120	0.1075	0.183	0.176	0.112	0.108	0.101	0.111	3/32	0.094	0.051	0.038	0.005	0.99	0.75
5	0.1250	0.1250	0.1202	0.205	0.198	0.125	0.121	0.112	0.111	3/32	0.094	0.057	0.043	0.005	1.00	0.75
6	0.1380	0.1380	0.1329	0.226	0.218	0.138	0.134	0.124	0.133	7/64	0.109	0.064	0.047	0.005	1.05	0.75
8	0.1640	0.1640	0.1585	0.270	0.262	0.164	0.159	0.148	0.168	9/64	0.141	0.077	0.056	0.005	1.19	0.88
10	0.1900	0.1900	0.1840	0.312	0.303	0.190	0.185	0.171	0.183	5/32	0.156	0.090	0.065	0.005	1.27	0.88
1/4	0.2500	0.2500	0.2435	0.375	0.365	0.250	0.244	0.225	0.216	3/16	0.188	0.120	0.095	0.008	1.50	1.00
5/16	0.3125	0.3125	0.3053	0.469	0.457	0.312	0.306	0.281	0.291	1/4	0.250	0.151	0.119	0.008	1.71	1.12
3/8	0.3750	0.3750	0.3678	0.562	0.550	0.375	0.368	0.337	0.372	5/16	0.312	0.182	0.143	0.008	1.94	1.25
7/16	0.4375	0.4375	0.4294	0.656	0.642	0.438	0.430	0.394	0.454	3/8	0.375	0.213	0.166	0.010	2.17	1.38
1/2	0.5000	0.5000	0.4919	0.750	0.735	0.500	0.492	0.450	0.454	3/8	0.375	0.245	0.190	0.010	2.38	1.50
5/8	0.6250	0.6250	0.6163	0.938	0.921	0.625	0.616	0.562	0.595	1/2	0.500	0.307	0.238	0.010	2.82	1.75
3/4	0.7500	0.7500	0.7406	1.125	1.107	0.750	0.740	0.675	0.620	5/8	0.625	0.370	0.285	0.010	3.25	2.00
7/8	0.8750	0.8750	0.8647	1.312	1.293	0.875	0.864	0.787	0.698	3/4	0.750	0.432	0.333	0.015	3.69	2.25
1	1.0000	1.0000	0.9886	1.500	1.479	1.000	0.988	0.900	0.790	3/4	0.750	0.495	0.380	0.015	4.12	2.50
1-1/8	1.1250	1.1250	1.1086	1.688	1.665	1.125	1.111	1.012	-	7/8	0.875	0.557	0.428	0.015	4.65	2.81
1-1/4	1.2500	1.2500	1.2336	1.875	1.852	1.250	1.236	1.125	-	7/8	0.875	0.620	0.475	0.015	5.09	3.12
1-3/8	1.3750	1.3750	1.3568	2.062	2.038	1.375	1.360	1.237	-	1	1.000	0.682	0.523	0.015	5.65	3.44
1-1/2	1.5000	1.5000	1.4818	2.250	2.224	1.500	1.485	1.350	-	1	1.000	0.745	0.570	0.015	6.08	3.75
1-3/4	1.7500	1.7500	1.7295	2.625	2.597	1.750	1.734	1.575	-	1-1/4	1.250	0.870	0.665	0.015	7.13	4.38
2	2.0000	2.0000	1.9780	3.000	2.970	2.000	1.983	1.800	-	1-1/2	1.500	0.995	0.760	0.015	8.11	5.00

NOTES FOR TABLE 1

1. LENGTH. The length of the screw is the distance measured on a line parallel to the axis, from the plane of the bearing surface under the head to the plane of the flat of the point. It includes the threads and body. The basic length dimension on the product shall be the nominal length expressed as a two-place decimal.

Balance of notes on page 2.

STANDARD LENGTH INCREMENTS, L

NOMINAL SCREW SIZE	NOMINAL SCREW LENGTH	STANDARD LENGTH INCREMENT
0 to 1 inch Incl.	1/8 thru 1/4	1/16
	1/4 thru 1	1/8
	1 thru 3-1/2	1/4
	3-1/2 thru 7	1/2
Over 1 inch	7 thru 10	1
	1 thru 7	1/2
	7 thru 10	1
	Over 10	2

LENGTH TOLERANCES, L

NOMINAL SCREW SIZE	0 Thru 3/8, Incl.	7/16, Thru 3/4, Incl.	7/8, Thru 1-1/2, Incl.	Over 1-1/2
	NOMINAL SCREW LENGTH TOLERANCE ON LENGTH			
Up to 1., Incl.	-0.03	-0.03	-0.05	-
Over 1 in. to 2-1/2, Incl.	-0.04	-0.06	-0.10	-0.18
Over 2-1/2 to 6, Incl.	-0.06	-0.08	-0.14	-0.20
Over 6	-0.12	-0.12	-0.20	-0.24

NOTES FOR TABLE 1 CONTINUED

2. **THREAD LENGTH.** L_T Thread length of the screw is the distance from the extreme point to the last complete or full form thread. See page 3 for grip and body lengths of standard length screws. L_{Tmax} in Table 1 refers to longer than standard length screws.

3. **BODY.** L_B The unthreaded cylindrical portion of the shank for screws that are not threaded to the head.

4. **HEAD DIAMETER.** Heads may be made plain or knurled at Holo-Krome's option unless specified on the order. For knurled screws, the maximum head diameter includes the knurling. Minimum head diameter is the diameter of the head before knurling, or any unknurled section or band on the head.

HEAD CONCENTRICITY. The heads of Holo-Krome Cap Screws are concentric with the shank within 1% of the basic screw diameter, D maximum (2% total runout), or 0.006 inch total runout, whichever is greater, when held within one diameter of the head but beyond the fillet.

5. **SOCKET CONCENTRICITY.** Holo-Krome Sockets are concentric with the shanks of the cap screws within 1-1/2% of the basic screw diameter, D maximum, (3% total runout), or 0.005 inch, whichever is greater for screws through a nominal size of 1/2 inch. Sizes above 1/2 inch have sockets concentric with the shank within 3% of the basic screw diameter, D maximum, (6% total runout). See page 13 for socket tolerances.

6. **BEARING SURFACE.** The plane of the bearing surface is perpendicular to the axis of the screw within a maximum deviation of 1 degree.

7. **THREADS AND GAGING.** Threads are Unified Standard radius root. On screws with a nominal size 0 through 1 inch inclusive, threads are Class 3A in both UNRC and UNRF. On nominal sizes over 1 inch, threads are made to Class 2A in both UNRC or UNRF. Holo-Krome screw threads have controlled radius roots and radiused runout for greater fatigue life. Acceptability of screw threads shall be based on System 22 of ANSI/ASME B1.3M.

Class 3A threads do not provide a plating allowance. When plating is required, it is recommended that Holo-Krome supply the parts plated.

8. **SCREW POINT CHAMFER.** The point shall be flat or slightly concave and chamfered. The plane of the point shall be approximately normal to the axis of the screw. The chamfer shall extend slightly below the root of the thread and the edge between the flat and chamfer may be slightly rounded. The included angle of the point should be approximately 90 degrees. Chamfering of screw sizes up to and including size 8 (0.164 in.) shall be optional.

9. **FILLET.** For all lengths of screws the form of the underhead fillet shall be optional, as depicted in Figure 1, provided it is a smooth and continuous concave curve fairing into the bearing surface of the head and the screw shank within the envelope established by the limits for fillet extension, length and juncture radius specified in Table 1A.

10. **TOTAL RUNOUT.** The total runout between the head, body and threads of socket cap screws shall be such that the screw will assemble into a compound hole that is threaded at one end to the basic thread size (Class 3B min.) for a depth equivalent to 1.5 times the basic screw diameter and drilled and counterbored as shown in Table 3. These diameters shall be concentric with the axis of the thread within 10% of the thread pitch diameter tolerance. The starting thread shall be chamfered and the corners shall be chamfered or rounded to a diameter equal to F max. Table 1A.

Applicable Standards and Specifications
ASME/ANSI B18.3 and ASTM A574

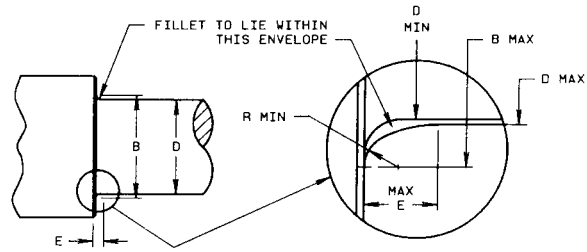

FIGURE 1 UNDERHEAD FILLET DETAIL

TABLE 1A DIMENSIONS OF UNDERHEAD FILLETS

NOMINAL SCREW SIZE	B	R	E
	TRANSITION DIAMETER	JUNCTURE RADIUS	FILLET LENGTH
	MAX.	MIN.	MAX.
0	0.074	0.002	0.012
1	0.087	0.003	0.012
2	0.102	0.003	0.014
3	0.115	0.004	0.014
4	0.130	0.004	0.015
5	0.195	0.005	0.017
6	0.158	0.005	0.017
8	0.188	0.006	0.020
10	0.218	0.006	0.024
1/4	0.278	0.007	0.024
5/16	0.347	0.009	0.029
3/8	0.415	0.012	0.034
7/16	0.494	0.014	0.039
1/2	0.552	0.016	0.044
5/8	0.689	0.021	0.054
3/4	0.828	0.025	0.066
7/8	0.963	0.031	0.075
1	1.100	0.034	0.085
1-1/8	1.235	0.039	0.094
1-1/4	1.370	0.044	0.102
1-3/8	1.505	0.048	0.110
1-1/2	1.640	0.052	0.119
1-3/4	1.910	0.062	0.136
2	2.180	0.071	0.153

SUPERSEDED DIMENSIONS — 1936 SERIES

The following table is included for reference only.

NOMINAL SIZE	HEAD DIAMETER	HEXAGON SOCKET SIZE	NOMINAL SIZE	HEAD DIAMETER	HEXAGON SOCKET SIZE
	MAX.	NOM.		MAX.	NOM.
0	—	—	3/8	—	—
1	—	0.050	7/16	5/8	5/16
2	—	1/16	1/2	—	—
3	—	—	5/8	7/8	—
4	—	5/64	3/4	1	9/16
5	—	—	7/8	1-1/8	9/16
6	—	3/32	1	1-5/16	5/8
8	—	1/8	1-1/8	1-1/2	3/4
10	—	—	1-1/4	1-3/4	3/4
1/4	—	—	1-3/8	1-7/8	3/4
5/16	7/16	7/32	1-1/2	2	—

TABLE 2 HOLO-KROME SOCKET HEAD CAP SCREWS - 1960 SERIES

GRIP LENGTH — L_G . The maximum distance from the bearing surface of the head to the first completed or full form thread. A clamped part thinner than L_G would not allow the screw to seat.

BODY LENGTH — L_B . The minimum length of the unthreaded cylindrical portion of the shank.

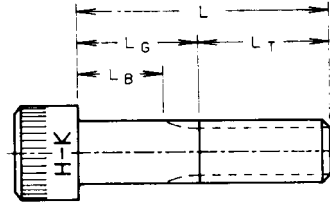

TABLE 2 BODY AND GRIP LENGTHS - 1960 SERIES - LENGTHS ABOVE LINE ARE THREADED TO THE HEAD

NOMINAL SIZE	0		1		2		3		4		5		6		8		10		
	L_G	L_B	L_G	L_B	L_G	L_B	L_G	L_B	L_G	L_B	L_G	L_B	L_G	L_B	L_G	L_B	L_G	L_B	
3/4	.25	.19																	
7/8	.25	.19	.25	.17	.25	.16	.25	.15											
1	.50	.44	.25	.17	.25	.16	.25	.15	.25	.12	.25	.12							
1-1/4	.75	.69	.62	.55	.62	.54	.62	.52	.25	.12	.25	.12	.50	.34	.38	.22	.38	.17	
1-1/2	—	—	.88	.80	.88	.79	.88	.77	.75	.62	.75	.62	.50	.34	.38	.22	.38	.17	
1-3/4	—	—	—	—	1.12	1.04	1.12	1.02	.75	.62	.75	.62	1.00	.84	.88	.72	.88	.67	
2	—	—	—	—	—	—	1.38	1.27	1.25	1.12	1.25	1.12	1.00	.84	.88	.72	.88	.67	
2-1/4	—	—	—	—	—	—	—	—	1.25	1.12	1.25	1.12	1.50	1.34	1.38	1.22	1.38	1.17	
2-1/2	—	—	—	—	—	—	—	—	—	—	1.75	1.62	1.50	1.34	1.38	1.22	1.38	1.17	
2-3/4	—	—	—	—	—	—	—	—	—	—	—	—	2.00	1.84	1.88	1.72	1.88	1.67	
3	—	—	—	—	—	—	—	—	—	—	—	—	—	—	1.88	1.72	1.88	1.67	
3-1/4	—	—	—	—	—	—	—	—	—	—	—	—	—	—	2.38	2.22	2.38	2.17	
3-1/2	—	—	—	—	—	—	—	—	—	—	—	—	—	—	—	—	—	2.38	2.17
3-3/4	—	—	—	—	—	—	—	—	—	—	—	—	—	—	—	—	—	2.88	2.67
4	—	—	—	—	—	—	—	—	—	—	—	—	—	—	—	—	—	2.88	2.67

NOMINAL SIZE	1/4		5/16		3/8		7/16		1/2		5/8		3/4		7/8		1.000	
	L_G	L_B	L_G	L_B	L_G	L_B	L_G	L_B	L_G	L_B	L_G	L_B	L_G	L_B	L_G	L_B	L_G	L_B
1-1/2	.50	.25																
1-3/4	.50	.25	.62	.35	.50	.19												
2	1.00	.75	.62	.35	.50	.19	.62	.27										
2-1/4	1.00	.75	1.12	.85	1.00	.69	.62	.27	.75	.36								
2-1/2	1.50	1.25	1.12	.85	1.00	.69	1.12	.77	.75	.36	.75	.30						
2-3/4	1.50	1.25	1.62	1.35	1.50	1.19	1.12	.77	.75	.36	.75	.30						
3	2.00	1.75	1.62	1.35	1.50	1.19	1.62	1.27	1.50	1.12	.75	.30	1.00	.50				
3-1/4	2.00	1.75	2.12	1.85	2.00	1.69	1.62	1.27	1.50	1.12	1.50	1.04	1.00	.50	1.00	.44		
3-1/2	2.50	2.25	2.12	1.85	2.00	1.69	2.12	1.77	1.50	1.12	1.50	1.04	1.00	.50	1.00	.44	1.00	.38
3-3/4	2.50	2.25	2.62	2.35	2.50	2.19	2.12	1.77	2.25	1.86	1.50	1.04	1.00	.50	1.00	.44	1.00	.38
4	3.00	2.75	2.62	2.35	2.50	2.19	2.62	2.27	2.25	1.86	2.25	1.80	2.00	1.50	1.00	.44	1.00	.38
4-1/4	3.00	2.75	3.12	2.85	3.00	2.69	2.62	2.27	2.25	1.86	2.25	1.80	2.00	1.50	2.00	1.44	1.00	.38
4-1/2	3.50	3.25	3.12	2.85	3.00	2.69	3.12	2.77	3.00	2.62	2.25	1.80	2.00	1.50	2.00	1.44	2.00	1.38
4-3/4	3.50	3.25	3.62	3.35	3.50	3.19	3.12	2.77	3.00	2.62	3.00	2.54	2.00	1.50	2.00	1.44	2.00	1.38
5	4.00	3.75	3.62	3.35	3.50	3.19	3.62	3.27	3.00	2.62	3.00	2.54	3.00	2.50	2.00	1.44	2.00	1.38
5-1/4	—	—	4.12	3.85	4.00	3.69	3.62	3.27	3.75	3.36	3.00	2.54	3.00	2.50	3.00	2.44	2.00	1.38
5-1/2	—	—	4.12	3.85	4.00	3.69	4.12	3.77	3.75	3.36	3.75	3.30	3.00	2.50	3.00	2.44	3.00	2.38
5-3/4	—	—	4.62	4.35	4.50	4.19	4.12	3.77	3.75	3.36	3.75	3.30	3.00	2.50	3.00	2.44	3.00	2.38
6	—	—	4.62	4.35	4.50	4.19	4.62	4.27	4.50	4.12	3.75	3.30	4.00	3.50	3.00	2.44	3.00	2.38
6-1/4	—	—	5.12	4.85	5.00	4.69	4.62	4.27	4.50	4.12	4.50	4.04	4.00	3.50	4.00	3.44	3.00	2.38
6-1/2	—	—	—	—	5.00	4.69	5.12	4.77	4.50	4.12	4.50	4.04	4.00	3.50	4.00	3.44	4.00	3.38
6-3/4	—	—	—	—	5.50	5.19	5.12	4.77	5.25	4.86	4.50	4.04	4.00	3.50	4.00	3.44	4.00	3.38
7	—	—	—	—	5.50	5.19	5.62	5.27	5.25	4.86	5.25	4.80	5.00	4.50	4.00	3.44	4.00	3.38
7-1/4	—	—	—	—	6.00	5.69	5.62	5.27	5.25	4.86	5.25	4.80	5.00	4.50	5.00	4.44	4.00	3.38
7-1/2	—	—	—	—	6.00	5.69	6.12	5.77	6.00	5.62	5.25	4.80	5.00	4.50	5.00	4.44	5.00	4.38
7-3/4	—	—	—	—	—	—	6.12	5.77	6.00	5.62	6.00	5.54	5.00	4.50	5.00	4.44	5.00	4.38
8	—	—	—	—	—	—	6.62	6.27	6.00	5.62	6.00	5.54	6.00	5.50	5.00	4.44	5.00	4.38
8-1/2	—	—	—	—	—	—	7.12	6.77	7.00	6.62	6.75	6.30	6.00	5.50	6.00	5.44	6.00	5.38
9	—	—	—	—	—	—	7.62	7.27	7.00	6.62	6.75	6.30	7.00	6.50	6.00	5.44	6.00	5.38
9-1/2	—	—	—	—	—	—	—	—	8.00	7.62	7.75	7.30	7.00	6.50	7.00	6.44	7.00	6.38
10	—	—	—	—	—	—	—	—	8.00	7.62	7.75	7.30	8.00	7.50	7.00	6.44	7.00	6.38
11	—	—	—	—	—	—	—	—	—	—	9.25	8.80	9.00	8.50	8.00	7.44	8.00	7.38
12	—	—	—	—	—	—	—	—	—	—	10.25	9.80	10.00	9.50	9.00	8.44	9.00	8.38
13	—	—	—	—	—	—	—	—	—	—	—	—	11.00	10.50	10.00	9.44	10.00	9.38
14	—	—	—	—	—	—	—	—	—	—	—	—	12.00	11.50	11.00	10.44	11.00	10.38
15	—	—	—	—	—	—	—	—	—	—	—	—	13.00	12.50	12.00	11.44	12.00	11.38
16	—	—	—	—	—	—	—	—	—	—	—	—	—	—	13.00	12.44	13.00	12.38
17	—	—	—	—	—	—	—	—	—	—	—	—	—	—	14.00	13.44	14.00	13.38
18	—	—	—	—	—	—	—	—	—	—	—	—	—	—	15.00	14.44	15.00	14.38
19	—	—	—	—	—	—	—	—	—	—	—	—	—	—	—	—	16.00	15.38
20	—	—	—	—	—	—	—	—	—	—	—	—	—	—	—	—	17.00	16.38

For longer lengths or diameters over 1" see Page 1 L_T , Table 1

TABLE 3 HOLO-KROME SOCKET HEAD CAP SCREWS - 1960 SERIES

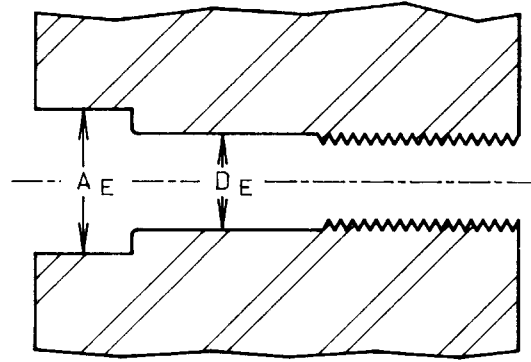

TABLE 3 FUNCTIONAL LIMITS FOR RUNOUT OF HEAD, BODY AND THREAD — 1960 SERIES

NOMINAL SIZE		0		1		2		3		4		5		6		8		10	
NOMINAL LENGTH		HOLE DIAMETERS FOR SHANK (D _E) AND FOR HEAD (A _E) ¹																	
OVER	TO, INCL.	D _E	A _E	D _E	A _E	D _E	A _E	D _E	A _E	D _E	A _E	D _E	A _E	D _E	A _E	D _E	A _E	D _E	A _E
0	1/4	.063	.105	.076	.127	—	—	—	—	—	—	—	—	—	—	—	—	—	—
1/4	1/2	.065	.107	.078	.129	—	—	—	—	—	—	—	—	—	—	—	—	—	—
1/2	3/4	.068	.110	.080	.131	—	—	—	—	—	—	—	—	—	—	—	—	—	—
3/4	1	.070	.112	.082	.133	—	—	—	—	—	—	—	—	—	—	—	—	—	—
1	1-1/2	—	—	.087	.138	—	—	—	—	—	—	—	—	—	—	—	—	—	—
0	1/2	—	—	—	—	.090	.150	.103	.171	.116	.193	—	—	—	—	—	—	—	—
1/2	1	—	—	—	—	.095	.155	.107	.175	.120	.197	—	—	—	—	—	—	—	—
1	1-1/2	—	—	—	—	.099	.159	.111	.179	.123	.200	—	—	—	—	—	—	—	—
1-1/2	2	—	—	—	—	.103	.163	.115	.183	.127	.204	—	—	—	—	—	—	—	—
2	2-1/2	—	—	—	—	—	—	—	—	.131	.208	—	—	—	—	—	—	—	—
0	3/4	—	—	—	—	—	—	—	—	—	—	.130	.216	.143	.237	.168	.280	—	—
3/4	1-1/2	—	—	—	—	—	—	—	—	—	—	.136	.222	.148	.242	.173	.285	—	—
1-1/2	2-1/4	—	—	—	—	—	—	—	—	—	—	.140	.226	.153	.247	.178	.290	—	—
2-1/4	3	—	—	—	—	—	—	—	—	—	—	.146	.232	.158	.252	.183	.295	—	—
3	4	—	—	—	—	—	—	—	—	—	—	.150	.236	.163	.257	.189	.301	—	—
0	1	—	—	—	—	—	—	—	—	—	—	—	—	—	—	—	—	.196	.324
1	2	—	—	—	—	—	—	—	—	—	—	—	—	—	—	—	—	.201	.329
2	3	—	—	—	—	—	—	—	—	—	—	—	—	—	—	—	—	.207	.335
3	4	—	—	—	—	—	—	—	—	—	—	—	—	—	—	—	—	.213	.341
4	6	—	—	—	—	—	—	—	—	—	—	—	—	—	—	—	—	.215	.346

NOMINAL SIZE		1/4		5/16		3/8		7/16		1/2		5/8		3/4		7/8		1	
NOMINAL LENGTH		HOLE DIAMETERS FOR SHANK (D _E) AND FOR HEAD (A _E) ¹																	
OVER	TO, INCL.	D _E	A _E	D _E	A _E	D _E	A _E	D _E	A _E	D _E	A _E	D _E	A _E	D _E	A _E	D _E	A _E	D _E	A _E
0	1	.255	.386	.317	.480	.379	.574	.441	.669	—	—	—	—	—	—	—	—	—	—
1	2	.260	.391	.322	.485	.383	.578	.445	.673	—	—	—	—	—	—	—	—	—	—
2	3	.265	.396	.326	.489	.387	.582	.449	.676	—	—	—	—	—	—	—	—	—	—
3	4	.270	.401	.331	.494	.391	.586	.453	.680	—	—	—	—	—	—	—	—	—	—
4	6	.275	.406	.337	.500	.400	.595	.462	.690	—	—	—	—	—	—	—	—	—	—
0	2	—	—	—	—	—	—	—	—	.507	.767	.631	.956	.756	1.146	.880	1.335	1.005	1.525
2	4	—	—	—	—	—	—	—	—	.514	.774	.638	.963	.762	1.152	.886	1.341	1.010	1.530
4	6	—	—	—	—	—	—	—	—	.521	.781	.644	.969	.767	1.157	.891	1.346	1.015	1.535
6	8	—	—	—	—	—	—	—	—	.525	.785	.650	.975	.773	1.163	.897	1.352	1.020	1.540
8	10	—	—	—	—	—	—	—	—	—	—	—	—	.775	1.165	.900	1.355	1.025	1.545

NOMINAL SIZE		1-1/8		1-1/4		1-3/8		1-1/2		1-3/4		2	
NOMINAL LENGTH		HOLE DIAMETERS FOR SHANK (D _E) AND FOR HEAD (A _E) ¹											
OVER	TO, INCL.	D _E	A _E	D _E	A _E	D _E	A _E	D _E	A _E	D _E	A _E	D _E	A _E
0	6	1.140	1.725	1.265	1.915	1.390	2.104	1.515	2.295	1.765	2.675	2.015	3.055
6	12	1.155	1.740	1.280	1.930	1.405	2.119	1.530	2.310	1.780	2.690	2.030	3.070
12	18	1.170	1.755	1.295	1.945	1.420	2.134	1.545	2.325	1.795	2.705	2.045	3.085
18	24	1.185	1.770	1.310	1.960	1.435	2.149	1.560	2.340	1.810	2.720	2.060	3.100

¹The largest diameter D_E and A_E specified for the various screw sizes in TABLE 3 shall apply for any nominal screw longer than that tabulated for the respective nominal screw size.

TABLE 4 CROSS DRILLING DIMENSIONS

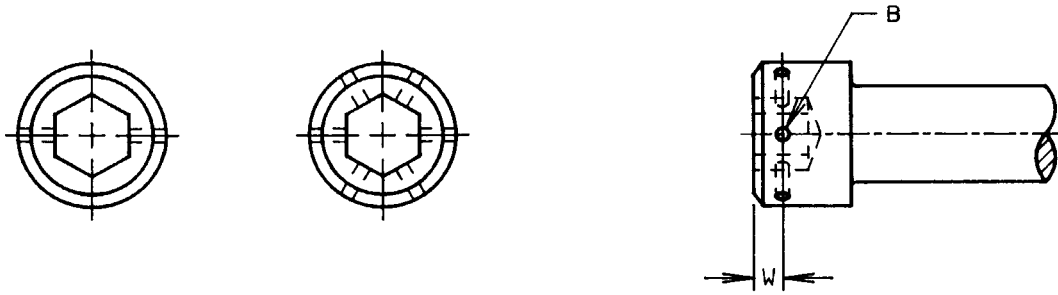

6 AND SMALLER

8 AND LARGER

TABLE 4 DIMENSIONS FOR DRILLED-HEAD SOCKET SCREWS

NOMINAL SIZE	W		B		HOLE ALIGNMENT PLUG DIAMETER
	TOP OF HEAD TO CENTER OF HOLE		DRILLED HOLE DIAMETER		
	MAX.	MIN.	MAX.	MIN.	
4	0.040	0.026	0.039	0.033	0.025
5	0.045	0.030	0.039	0.033	0.025
6	0.050	0.035	0.039	0.033	0.025
8	0.060	0.040	0.050	0.044	0.030
10	0.065	0.045	0.050	0.044	0.030
1/4	0.085	0.065	0.050	0.044	0.030
5/16	0.104	0.084	0.050	0.044	0.030
3/8	0.123	0.103	0.067	0.061	0.051
7/16	0.141	0.121	0.067	0.061	0.051
1/2	0.160	0.140	0.067	0.061	0.051
5/8	0.198	0.178	0.067	0.061	0.051
3/4	0.235	0.215	0.097	0.091	0.081
7/8	0.273	0.253	0.097	0.091	0.081
1	0.310	0.290	0.097	0.091	0.081
1 1/8	0.348	0.328	0.127	0.119	0.104
1 1/4	0.385	0.365	0.127	0.119	0.104
1 3/8	0.423	0.403	0.127	0.119	0.104
1 1/2	0.460	0.440	0.127	0.119	0.104

TABLE 5 HOLO-KROME SOCKET HEAD CAP SCREWS — 1960 SERIES

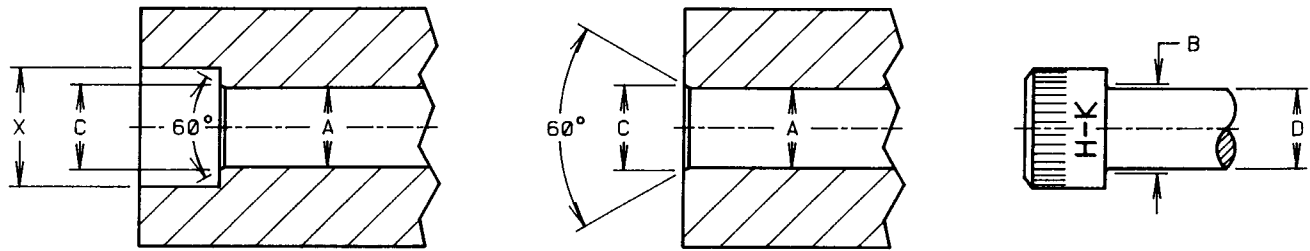

TABLE 5 DRILL AND COUNTERBORE SIZES — 1960 SERIES

NOMINAL SIZE	BASIC SCREW DIAMETER	A				X	C
		DRILL SIZE FOR HOLE A					
		CLOSE FIT		NORMAL FIT			
		NOM.	DEC.	NOM.	DEC.		
0	0.0600	51*	0.0670	49*	0.0730	1/8	0.074
1	0.0730	46*	0.0810	43*	0.0890	5/32	0.087
2	0.0860	3/32	0.0937	36*	0.1065	3/16	0.102
3	0.0990	36*	0.1065	31*	0.1200	7/32	0.115
4	0.1120	1/8	0.1250	29*	0.1360	7/32	0.130
5	0.1250	9/64	0.1406	23*	0.1540	1/4	0.145
6	0.1380	23*	0.1540	18*	0.1695	9/32	0.158
8	0.1640	15*	0.1800	10*	0.1935	5/16	0.188
10	0.1900	5*	0.2055	2*	0.2210	3/8	0.218
1/4	0.2500	17/64	0.2656	9/32	0.2812	7/16	0.278
5/16	0.3125	21/64	0.3281	11/32	0.3437	17/32	0.346
3/8	0.3750	25/64	0.3906	13/32	0.4062	5/8	0.415
7/16	0.4375	29/64	0.4531	15/32	0.4687	23/32	0.483
1/2	0.5000	33/64	0.5156	17/32	0.5312	13/16	0.552
5/8	0.6250	41/64	0.6406	21/32	0.6562	1	0.689
3/4	0.7500	49/64	0.7656	25/32	0.7812	1-3/16	0.828
7/8	0.8750	57/64	0.8906	29/32	0.9062	1-3/8	0.963
1	1.0000	1-1/64	1.0156	1-1/32	1.0312	1-5/8	1.100
1-1/4	1.2500	1-9/32	1.2812	1-5/16	1.3125	2	1.370
1-1/2	1.5000	1-17/32	1.5312	1-9/16	1.5625	2-3/8	1.640
1-3/4	1.7500	1-25/32	1.7812	1-13/16	1.8125	2-3/4	1.910
2	2.0000	2-1/32	2.0312	2-1/16	2.0625	3-1/8	2.180

*Wire size drill

NOTES FOR TABLE 5

CLOSE FIT. Normally limited to holes for those lengths of screws threaded to the head in assemblies in which (1) only one screw is used, or (2) two or more screws are used and the mating holes are produced at assembly or by matched and coordinated tooling.

NORMAL FIT. Intended for (1) screws of relatively long length or (2) assemblies that involve two or more screws and where the mating holes are produced by conventional tolerancing methods. It provides for the maximum allowable eccentricity of the longest standard screws and for certain deviations in the parts being fastened, such as deviations in hole straightness; angularity between the axis of the tapped hole and that of the hole for the shank; differences in center distances of the mating holes and other deviations.

CHAMFERING. It is considered good practice to chamfer or break the edges of holes that are smaller than B maximum in parts in which hardness approaches, equals or exceeds the screw hardness. If holes are not chamfered, the heads may not seat properly or the sharp edges may deform the fillets on the screws, making them susceptible to fatigue in applications that involve dynamic loading. The chamfers, however, should not be larger than needed to ensure that the heads seat properly or that the fillet on the screw is not deformed. Normally the chamfers need not exceed B maximum. Chamfers exceeding these values reduce the effective bearing area and introduce the possibility of indentation when the parts fastened are softer than the screws, or of brinnelling of the heads of the screws when the parts are harder than the screws.

TABLE 6 DIMENSIONS FOR SEMS

SOCKET HEAD CAP SCREWS FOR SEMS

The socket head cap screw component of sems shall conform to the specifications for cap screws published in American National Standard ASME/ANSI B18.3 except (1) that the maximum diameter of the unthreaded shank shall be less than the maximum major diameter of the thread by an amount sufficient to prevent disassembly of the washer from the screw; and (2) that on short length screws where unthreaded length applies, the full form threads shall extend to within two pitches (threads) of the contacting face of the washer or closer if practicable. Where required, threads extending closer than two pitches (threads) of the contacting face of the washer may be negotiated between the manufacturer and purchaser.

WASHERS FOR SEMS

The washer components of sems shall conform with the dimensions and specifications given for the various types in this standard. It should be noted that the washers for sems may differ dimensionally from the equivalent over-the-thread washers as specified in American National Standards, ANSI B18.21.1 and ANSI B18.22.1. Except for helical spring lock washers where the inside diameters are included for manufacturing purposes, the holes in the sems washers are not specified in as much as the washers shall be assembled onto the screw blanks before the threads are rolled. The edge contour of the hole on the head side of washer and the size relationship between the washer inside diameter and the diameter of the unthreaded shank on the screw shall be such that the washer will be retained on the screw after the threads are rolled but shall not bind on the shank or impinge on the underhead fillet of the screw before or during tightening of the assembly.

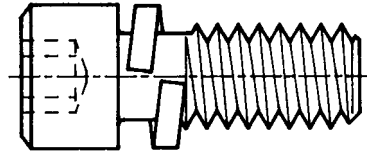

TABLE 6 DIMENSIONS OF HELICAL SPRING LOCK WASHERS FOR SOCKET HEAD CAP SCREW SEMS

NOMINAL SIZE	BASIC SCREW DIAMETER	WASHER INSIDE DIAMETER		WASHER SECTION		WASHER OUTSIDE DIAMETER	
				WIDTH	THICKNESS		
		MAX.	MIN.	MAX.	MIN.	MAX.	MIN.
2	0.0860	0.080	0.075	0.022	0.022	0.129	0.119
3	0.0990	0.091	0.086	0.030	0.030	0.158	0.147
4	0.1120	0.106	0.101	0.030	0.030	0.174	0.161
5	0.1250	0.118	0.113	0.040	0.040	0.206	0.193
6	0.1380	0.129	0.124	0.040	0.040	0.217	0.204
8	0.1640	0.155	0.149	0.047	0.047	0.257	0.243
10	0.1900	0.179	0.173	0.062	0.047	0.311	0.297
1/4	0.2500	0.238	0.230	0.062	0.062	0.370	0.354
3/16	0.3125	0.298	0.290	0.078	0.078	0.462	0.446
3/8	0.3750	0.361	0.353	0.094	0.094	0.557	0.541
7/16	0.4375	0.420	0.411	0.109	0.109	0.646	0.629
1/2	0.5000	0.482	0.473	0.125	0.125	0.740	0.723
5/8	0.6250	0.601	0.592	0.156	0.156	0.921	0.904
3/4	0.7500	0.722	0.713	0.188	0.188	1.106	1.089

Applicable Standards and Specifications
ASME/ANSI B18.13

TABLE 6A DIMENSIONS FOR SEMS



TABLE 6A DIMENSIONS OF PLAIN WASHERS FOR SEMS

NOMINAL SIZE	BASIC SCREW DIAMETER	WASHER OUTSIDE DIAMETER		WASHER THICKNESS		
		MAX.	MIN.	BASIC	MAX.	MIN.
2	0.0860	0.188	0.183	0.025	0.028	0.022
3	0.0990	0.219	0.214	0.025	0.028	0.022
4	0.1120	0.250	0.245	0.032	0.036	0.028
5	0.1250	0.281	0.276	0.032	0.036	0.028
6	0.1380	0.312	0.307	0.032	0.036	0.028
8	0.1640	0.383	0.370	0.032	0.036	0.028
10	0.1900	0.446	0.433	0.040	0.045	0.036
1/4	0.2500	0.515	0.495	0.063	0.071	0.056
5/16	0.3125	0.640	0.620	0.063	0.071	0.056
3/8	0.3750	0.749	0.727	0.063	0.071	0.056
7/16	0.4375	0.890	0.868	0.063	0.071	0.056
1/2	0.5000	1.015	0.993	0.063	0.071	0.056

TABLE 6B DIMENSIONS OF CONICAL SPRING WASHERS FOR SEMS

NOMINAL SIZE	BASIC SCREW DIAMETER	WASHER OUTSIDE DIAMETER		TYPE L WASHER					TYPE H WASHER				
				THICKNESS			CROWN HEIGHT		THICKNESS			CROWN HEIGHT	
		MAX .	MIN.	BASIC	MAX.	MIN.	MAX .	MIN.	BASIC	MAX .	MIN.	MAX .	MIN.
6	0.1380	0.320	0.307	0.025	0.029	0.023	0.016	0.010	0.035	0.040	0.033	0.016	0.010
8	0.1640	0.383	0.370	0.035	0.040	0.033	0.016	0.010	0.040	0.046	0.037	0.016	0.010
10	0.1900	0.446	0.433	0.035	0.040	0.033	0.016	0.010	0.050	0.056	0.047	0.017	0.011
1/4	0.2500	0.515	0.495	0.045	0.050	0.042	0.024	0.014	0.064	0.071	0.059	0.021	0.011
5/16	0.3125	0.640	0.620	0.055	0.060	0.052	0.026	0.016	0.079	0.087	0.074	0.026	0.016
3/8	0.3750	0.765	0.743	0.071	0.079	0.066	0.025	0.015	0.095	0.103	0.090	0.024	0.014
7/16	0.4375	0.890	0.868	0.079	0.087	0.074	0.028	0.018	0.128	0.136	0.122	0.026	0.016
1/2	0.5000	1.015	0.993	0.100	0.108	0.094	0.031	0.021	0.142	0.150	0.136	0.030	0.020

TABLE 7 HOLO-KROME SOCKET LOW HEAD CAP SCREWS

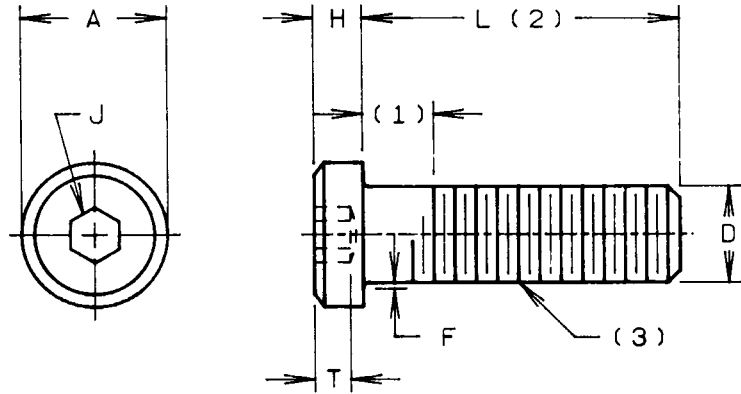

TABLE 7 DIMENSIONS

NOMINAL SIZE	BASIC SCREW DIAMETER	A		H		J		T	F	
		HEAD DIAMETER		HEAD HEIGHT		HEXAGON SOCKET SIZE		KEY ENGAGEMENT	FILLET EXTENSION	
		MAX.	MIN.	MAX.	MIN.	NOM.	MIN.	MAX.	MIN.	
4	0.1120	0.183	0.178	0.056	0.053	0.0500	0.038	0.009	0.005	
5	0.1250	0.205	0.200	0.062	0.059	1/16 0.062	0.044	0.010	0.006	
6	0.1380	0.226	0.221	0.069	0.066	1/16 0.062	0.050	0.010	0.006	
8	0.1640	0.270	0.265	0.082	0.079	5/64 0.078	0.060	0.012	0.007	
10	0.1900	0.312	0.307	0.095	0.092	3/32 0.094	0.072	0.014	0.009	
1/4	0.2500	0.375	0.369	0.125	0.121	1/8 0.125	0.094	0.014	0.009	
5/16	0.3125	0.437	0.431	0.156	0.152	5/32 0.156	0.120	0.017	0.012	
3/8	0.3750	0.562	0.556	0.187	0.182	3/16 0.188	0.145	0.020	0.015	
7/16	0.4375	0.625	0.618	0.218	0.213	7/32 0.219	0.166	0.023	0.018	
1/2	0.5000	0.750	0.743	0.250	0.244	1/4 0.250	0.184	0.026	0.020	
5/8	0.6250	0.875	0.867	0.312	0.306	5/16 0.312	0.250	0.032	0.024	

NOTES FOR TABLE 7

1. **THREAD LENGTH.** On all stock lengths the last complete (full form) thread measured with a thread ring gage (having the thread chamfer and/or counterbore removed) extends to within two threads of the head. On other lengths and diameters the length of thread will conform to socket head cap screw thread lengths.

2. **SCREW LENGTH.** The length of the screw is the distance measured on a line parallel to the axis, from the plane of the bearing surface under the head to the plane of the flat of the point. The basic length dimension on the product shall be the nominal length, expressed as a two-place decimal.

STANDARD LENGTH INCREMENTS, L

Nominal Screw Length	Standard Length Increment
1/8 thru 1/4	1/16
1/4 thru 1	1/8
1 thru 2	1/4

3. **THREADS AND GAGING.** Threads are Class 3A UNRC and UNRF with Holo-Krome controlled radius root and radiused runout. Acceptability of screw threads shall be based on System 22 of ANSI/ASME B1.3M. Class 3A threads do not provide a plating allowance. When plating is required, it is recommended that Holo-Krome supply the parts plated.

4. **SOCKETS.** Thermo-Forging®, a Holo-Krome patented process, provides accurately formed sockets without broaching chips. Because Thermo-Forging is not a machining process, it does not shear metal grains and sockets can be deeper and much stronger.

LENGTH TOLERANCES, L

Nominal Screw Size	4 thru 3/8, Inclusive	1/2 and 5/8, Inclusive
Nominal Screw Length	Tolerance on Length	
Up to 1 in., Incl.	-0.03	-0.03
Over 1 in. to 2-1/2, Incl.	-0.04	-0.06

TABLE 8 HOLO-KROME SOCKET FLAT COUNTERSUNK HEAD CAP SCREWS

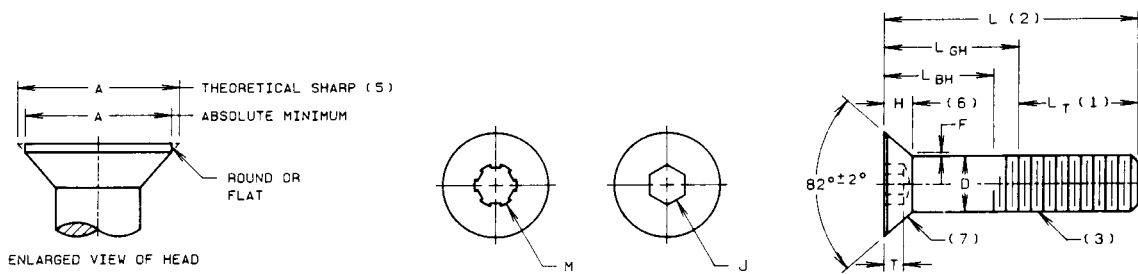

TABLE 8 DIMENSIONS

NOMINAL SIZE	BASIC SCREW DIAMETER	D		A		H		M	J	T	F
		BODY DIAMETER		HEAD DIAMETER		HEAD HEIGHT		SPLINE SOCKET SIZE	HEXAGON SOCKET SIZE	KEY ENGAGEMENT	FILLET EXTENSION ABOVE D MAX
		MAX.	MIN.	MAX. THEORETICAL SHARP	ABSOLUTE MIN.	REFERENCE	FLUSHNESS TOLERANCE	NOM.	NOM.	MIN.	MAX.
0	0.0600	0.0600	0.0568	0.138	0.117	0.044	0.006	0.048		0.025	0.006
1	0.0730	0.0730	0.0695	0.168	0.143	0.054	0.007	0.060		0.031	0.008
2	0.0860	0.0860	0.0822	0.197	0.168	0.064	0.008	0.060	0.050	0.038	0.010
3	0.0990	0.0990	0.0949	0.226	0.193	0.073	0.010	0.072	1/16 0.062	0.044	0.010
4	0.1120	0.1120	0.1075	0.255	0.218	0.083	0.011	0.072	1/16 0.062	0.055	0.012
5	0.1250	0.1250	0.1202	0.281	0.240	0.090	0.012	0.096	5/64 0.078	0.061	0.014
6	0.1380	0.1380	0.1329	0.307	0.263	0.097	0.013	0.096	5/64 0.078	0.066	0.015
8	0.1640	0.1640	0.1585	0.359	0.311	0.112	0.014	0.111	3/32 0.094	0.076	0.015
10	0.1900	0.1900	0.1840	0.411	0.359	0.127	0.015	0.145	1/8 0.125	0.087	0.015
1/4	0.2500	0.2500	0.2435	0.531	0.480	0.161	0.016	0.183	5/32 0.156	0.111	0.015
5/16	0.3125	0.3125	0.3053	0.656	0.600	0.198	0.017	0.216	3/16 0.188	0.135	0.015
3/8	0.3750	0.3750	0.3678	0.781	0.720	0.234	0.018	0.251	7/32 0.219	0.159	0.015
7/16	0.4375	0.4375	0.4294	0.844	0.781	0.234	0.018	0.291	1/4 0.250	0.159	0.015
1/2	0.5000	0.5000	0.4919	0.938	0.872	0.251	0.018	0.372	5/16 0.312	0.172	0.015
5/8	0.6250	0.6250	0.6163	1.188	1.112	0.324	0.022	0.454	3/8 0.375	0.220	0.015
3/4	0.7500	0.7500	0.7406	1.438	1.355	0.396	0.024	0.454	1/2 0.500	0.220	0.015
7/8	0.8750	0.8750	0.8647	1.688	1.604	0.468	0.025	-	9/16 0.562	0.248	0.015
1	1.0000	1.0000	0.9886	1.938	1.841	0.540	0.028	-	5/8 0.625	0.297	0.015

1. **THREAD LENGTH, L_T .** The length of the thread shall be measured, parallel to the axis of the screw, from the extreme point to the last complete (full form) thread.

2. **SCREW LENGTH.** The length of the screw is measured, parallel to the screw axis, from the plane of the top of the head to the plane of the flat of the point. The basic length dimension on the product shall be the nominal length expressed as a two-place decimal.

STANDARD LENGTH TOLERANCES, L

Nominal Screw Size	Nominal Screw Length	Standard Length Increment
0 to 1 inch Incl.	1/8 thru 1/4	1/16
	1/4 thru 1	1/8
	1 thru 3-1/2	1/4
	3-1/2 thru 7	1/2
	7 thru 10	1

LENGTH TOLERANCES, L

Nominal Screw Size	0 thru 3/8, Incl.	7/16 thru 3/4, Incl.	7/8 thru 1-1/2, Incl.
Nominal Screw Length	Tolerance on Length		
Up to 1 in., Incl.	-0.03	-0.03	-0.05
Over 1 in. to 2-1/2, Incl.	-0.04	-0.06	-0.10
Over 2-1/2 to 6, Incl.	-0.06	-0.08	-0.14
Over 6	-0.12	-0.12	-0.20

3. **THREADS.** Threads are Class 3A UNRC and UNRF with Holo-Krome controlled radius root, and radiused runout.

Class 3A threads do not provide a plating allowance. When plating is required, it is recommended that Holo-Krome supply the parts plated.

4. **SOCKETS.** Thermo-Forging®, a Holo-Krome patented process, provides accurately formed sockets without broaching chips. Because Thermo-Forging is not a machining process, it does not shear metal grains and sockets can be deeper and much stronger.

5. **HEAD DIAMETERS.** The maximum sharp values under Column A are theoretical values only as it is not practical to make the edges of the head sharp. The maximum sharp value represents the exact diameter of a hole countersunk to exactly 82° in which a screw having maximum head size will just fit flush.

6. **HEAD HEIGHT.** The tabulated values for head height are given for reference only and are calculated to the maximum formulation.

7. **BEARING SURFACE.** The axis of the conical bearing surface shall be parallel to the axis of the body within 1/2°.

Applicable Standards and Specifications
ASME/ANSI B18.3 and ASTM F835

TABLE 9 HOLO-KROME SOCKET FLAT COUNTERSUNK HEAD CAP SCREWS

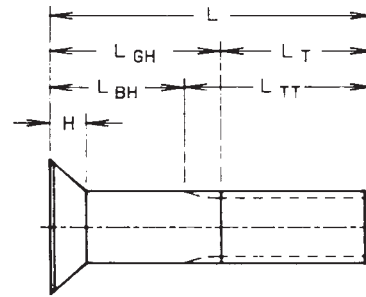

TABLE 9 BODY AND GRIP LENGTHS

NOMINAL SIZE	0		1		2		3		4		5		6		8		10		
NOMINAL LENGTH	L _{GH}	L _{BH}	L _{GH}	L _{BH}	L _{GH}	L _{BH}	L _{GH}	L _{BH}	L _{GH}	L _{BH}	L _{GH}	L _{BH}	L _{GH}	L _{BH}	L _{GH}	L _{BH}	L _{GH}	L _{BH}	
3/4	0.25	0.19																	
7/8	0.25	0.19	0.25	0.17	0.25	0.16	0.25	0.15											
1	0.50	0.44	0.25	0.17	0.25	0.16	0.25	0.15											
1-1/4	0.75	0.69	0.62	0.55	0.62	0.54	0.62	0.52	0.50	0.38	0.50	0.38	0.50	0.34	0.38	0.22			
1-1/2	—	—	0.88	0.80	0.88	0.79	0.88	0.77	0.50	0.38	0.50	0.38	0.50	0.34	0.38	0.22	0.62	0.42	
1-3/4	—	—	—	—	1.12	1.04	1.12	1.02	1.00	0.88	1.00	0.88	1.00	0.84	0.88	0.72	0.62	0.42	
2	—	—	—	—	—	—	—	—	1.00	0.88	1.00	0.88	1.00	0.84	0.88	0.72	1.12	0.92	
2-1/4	—	—	—	—	—	—	—	—	1.50	1.38	1.50	1.38	1.50	1.34	1.38	1.22	1.12	0.92	
2-1/2	—	—	—	—	—	—	—	—	—	—	—	—	1.50	1.34	1.38	1.22	1.62	1.42	
2-3/4	—	—	—	—	—	—	—	—	—	—	—	—	2.00	1.84	1.88	1.72	1.62	1.42	
3	—	—	—	—	—	—	—	—	—	—	—	—	—	—	—	1.88	1.72	2.12	1.92
3-1/4	—	—	—	—	—	—	—	—	—	—	—	—	—	—	2.38	2.22	2.12	1.92	
3-1/2	—	—	—	—	—	—	—	—	—	—	—	—	—	—	—	—	—	2.62	2.42
3-3/4	—	—	—	—	—	—	—	—	—	—	—	—	—	—	—	—	—	2.62	2.42
4	—	—	—	—	—	—	—	—	—	—	—	—	—	—	—	—	—	3.12	2.92

NOMINAL SIZE	1/4		5/16		3/8		7/16		1/2		5/8		3/4		7/8		1	
NOMINAL LENGTH	L _{GH}	L _{BH}	L _{GH}	L _{BH}	L _{GH}	L _{BH}	L _{GH}	L _{BH}	L _{GH}	L _{BH}	L _{GH}	L _{BH}	L _{GH}	L _{BH}	L _{GH}	L _{BH}	L _{GH}	L _{BH}
1-3/4	0.75	0.50																
2	0.75	0.50	0.88	0.60														
2-1/4	1.25	1.00	0.88	0.60	1.00	0.69												
2-1/2	1.25	1.00	1.38	1.10	1.00	0.69	1.12	0.77	1.00	0.62								
2-3/4	1.75	1.50	1.38	1.10	1.50	1.19	1.12	0.77	1.00	0.62								
3	1.75	1.50	1.88	1.60	1.50	1.19	1.62	1.27	1.00	0.62								
3-1/4	2.25	2.00	1.88	1.60	2.00	1.69	1.62	1.27	1.75	1.36	1.50	1.04						
3-1/2	2.25	2.00	2.38	2.10	2.00	1.69	2.12	1.77	1.75	1.36	1.50	1.04	1.50	1.00				
3-3/4	2.75	2.50	2.38	2.10	2.50	2.19	2.12	1.77	1.75	1.36	1.50	1.04	1.50	1.00	1.50	0.94		
4	2.75	2.50	2.88	2.60	2.50	2.19	2.62	2.27	2.50	2.12	2.25	1.80	1.50	1.00	1.50	0.94	1.50	0.88
4-1/4	3.25	3.00	2.88	2.60	3.00	2.69	2.62	2.27	2.50	2.12	2.25	1.80	1.50	1.00	1.50	0.94	1.50	0.88
4-1/2	3.25	3.00	3.38	3.10	3.00	2.69	3.12	2.77	2.50	2.12	2.25	1.80	2.50	2.00	1.50	0.94	1.50	0.88
4-3/4	3.75	3.50	3.38	3.10	3.50	3.19	3.12	2.77	3.25	2.86	3.00	2.54	2.50	2.00	2.50	1.94	1.50	0.88
5	3.75	3.50	3.88	3.60	3.50	3.19	3.62	3.27	3.25	2.86	3.00	2.54	2.50	2.00	2.50	1.94	2.50	1.88
5-1/4	4.25	4.00	3.88	3.60	4.00	3.69	3.62	3.27	3.25	2.86	3.00	2.54	2.50	2.00	2.50	1.94	2.50	1.88
5-1/2	—	—	4.38	4.10	4.00	3.69	4.12	3.77	4.00	3.62	3.75	3.30	3.50	3.00	2.50	1.94	2.50	1.88
5-3/4	—	—	4.38	4.10	4.50	4.19	4.12	3.77	4.00	3.62	3.75	3.30	3.50	3.00	3.50	2.94	2.50	1.88
6	—	—	4.88	4.60	4.50	4.19	4.62	4.27	4.00	3.62	3.75	3.30	3.50	3.00	3.50	2.94	3.50	2.88

NOTES FOR TABLES 9 AND 9A

- GRIP GAGING LENGTH, L_{GH}. The grip gaging length is the distance, measured parallel to the axis of screw, from the top of the head to the first complete (full form) thread under the head.
- BODY LENGTH L_{BH}. The body length is the length, measured parallel to axis of screw, of the unthreaded portion of the shank and the head height.
- CONCENTRICITY. Concentricity of the thread with the body shall be within 0.005 in. per inch of body length (unthreaded portion) full (total) indicator reading, taken directly under the head when the screw is held by the full threads closest to the head of the screw and shall not exceed 0.025 in.
- For screws of nominal lengths longer than those shown in Table 10, and for screws over 1 in. in diameter, the L_{GH} max. and L_{BH} min. shall be determined as shown in Table 10A: L_{GH} = (L-L_T), L_{BH} = (L-L_{TT}).

TABLE 9A (For Screws Beyond Sizes in Table 9)

NOMINAL SIZE OR BASIC SCREW DIAMETER	L _T		L _{TT}		NOMINAL SIZE OR BASIC SCREW DIAMETER	L _T		L _{TT}	
	THREAD LENGTH	TOTAL THREAD LENGTH	THREAD LENGTH	TOTAL THREAD LENGTH		THREAD LENGTH	TOTAL THREAD LENGTH		
								MIN.	MAX.
0	0.0600	0.50	0.62	7/16	0.4375	1.38	2.17		
1	0.0730	0.62	0.77	1/2	0.5000	1.50	2.38		
2	0.0860	0.62	0.80	5/8	0.6250	1.75	2.82		
3	0.0990	0.62	0.83	3/4	0.7500	2.00	3.25		
4	0.1120	0.75	0.99	7/8	0.8750	2.25	3.69		
5	0.1250	0.75	1.00	1	1.0000	2.50	4.12		
6	0.1380	0.75	1.05						
8	0.1640	0.88	1.19						
10	0.1900	0.88	1.27						
1/4	0.2500	1.00	1.50						
5/16	0.3125	1.12	1.71						
3/8	0.3750	1.25	1.94						

TABLE 10 HOLO-KROME SOCKET BUTTON HEAD CAP SCREWS

NOTE: THIS PRODUCT IS DESIGNED FOR LIGHT FASTENING APPLICATIONS ONLY, SUCH AS SHEETMETAL COVERS, PLASTIC GUARDS, ETC. IT SHOULD NOT BE USED IN CRITICAL HIGH STRENGTH APPLICATIONS WHERE SOCKET HEAD CAPSCREWS SHOULD BE USED.

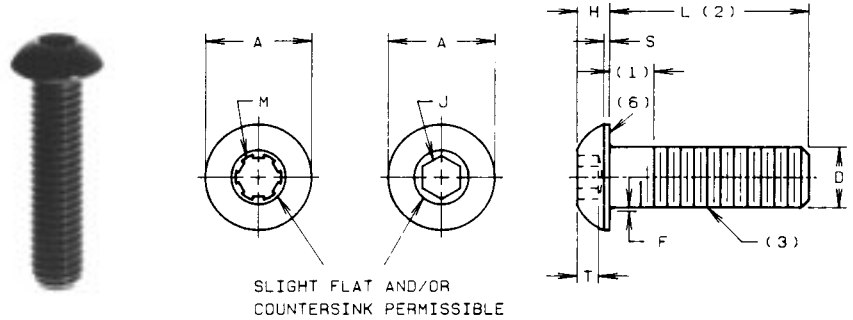

TABLE 10 DIMENSIONS

NOMINAL SIZE	BASIC SCREW DIAMETER	A		H		S	M	J		T	F		L
		HEAD DIAMETER		HEAD DIAMETER		HEAD SIDE HEIGHT	SPLINE SOCKET SIZE	HEXAGON SOCKET SIZE		KEY ENGAGEMENT	FILLET EXTENSION		MAXIMUM STANDARD LENGTH
		MAX.	MIN.	MAX.	MIN.	REF.	NOM.	NOM.	NOM.	MIN.	MAX.	MIN.	NOM.
0	0.0600	0.114	0.104	0.032	0.026	0.010	0.048	0.035	0.020	0.010	0.005	1/2	
1	0.0730	0.139	0.129	0.039	0.033	0.010	0.060	0.050	0.028	0.010	0.005	1/2	
2	0.0860	0.164	0.154	0.046	0.038	0.010	0.060	0.050	0.028	0.010	0.005	1/2	
3	0.0990	0.188	0.176	0.052	0.044	0.010	0.072	1/16 0.062	0.035	0.010	0.005	1/2	
4	0.1120	0.213	0.201	0.059	0.051	0.015	0.072	1/16 0.062	0.035	0.010	0.005	1/2	
5	0.1250	0.238	0.226	0.066	0.058	0.015	0.096	5/64 0.078	0.044	0.010	0.005	1/2	
6	0.1380	0.262	0.250	0.073	0.063	0.015	0.096	5/64 0.078	0.044	0.010	0.005	5/8	
8	0.1640	0.312	0.298	0.087	0.077	0.015	0.111	3/32 0.094	0.052	0.015	0.010	3/4	
10	0.1900	0.361	0.347	0.101	0.091	0.020	0.145	1/8 0.125	0.070	0.015	0.010	1	
1/4	0.2500	0.437	0.419	0.132	0.122	0.031	0.183	5/32 0.156	0.087	0.020	0.015	1	
5/16	0.3125	0.547	0.527	0.166	0.152	0.031	0.216	3/16 0.188	0.105	0.020	0.015	1	
3/8	0.3750	0.656	0.636	0.199	0.185	0.031	0.251	7/32 0.219	0.122	0.020	0.015	1-1/4	
1/2	0.5000	0.875	0.851	0.265	0.245	0.046	0.372	5/16 0.312	0.175	0.030	0.020	2	
5/8	0.6250	1.000	0.970	0.331	0.311	0.062	0.454	3/8 0.375	0.210	0.030	0.020	2	

NOTES FOR TABLE 10

1. **THREAD LENGTH.** On all stock lengths the last complete (full form) thread measured with a thread ring gage (having the thread chamfer and/or counterbore removed) extends to within two threads of the head. On other lengths and diameters the length of thread will conform to Socket Head Cap Screw thread lengths.

2. **SCREW LENGTH.** The length of the screw is the distance measured on a line parallel to the axis, from the plane of the bearing surface under the head to the plane of the flat of the point. The basic length dimension on the product shall be the nominal length expressed as a two-place decimal.

3. **THREADS AND GAGING.** Threads are Class 3A UNRC and UNRF with Holo-Krome controlled radiused root and radiused runout. Acceptability of screw threads shall be based on System 22 of ANSI/ASME B1.3M. Class 3A threads do not provide a plating allowance. When plating is required, it is recommended that Holo-Krome supply the parts plated.

STANDARD LENGTH INCREMENTS, L		
Nominal Screw Length	Standard Length Increment	
1/8 thru 1/4	1/16	
1/4 thru 1	1/8	
1 thru 2	1/4	
LENGTH TOLERANCES		
Nominal Screw Size	0 thru 3/8, Inclusive	1/2 and 5/8, Inclusive
Nominal Screw Length	Tolerance on Length	
Up to 1 in., Inc.	-0.03	-0.03
Over 1 in. to 2-1/2, Incl.	-0.04	-0.06

Applicable Standards and Specifications
ASME/ANSI B18.3 and ASTM F835

4. **SOCKETS.** Thermo forging®, a Holo-Krome patented process, provides accurately formed sockets without broaching chips. Because Thermo-Forging is not a machining process, it does not shear metal grains and sockets can be deeper and much stronger.

5. **FILLET.** For all lengths of screws, the form of the fillet shall be optional, provided it fairs into the bearing surface within the limits of the thread major diameter maximum plus F maximum, and the thread major diameter minimum, plus F minimum and is smooth and continuous curve having a bearing surface juncture radius no less than that tabulated below:

Nominal Screw Size	Juncture Radius Min.	Nominal Screw Size	Juncture Radius Min.
0	.002	10	.006
1	.003	1/4	.007
2	.003	5/16	.009
3	.004	3/8	.012
4	.004	1/2	.016
5	.005	5/8	.021
6	.005		
8	.006		

6. **BEARING SURFACE.** The plane of the bearing surface shall be perpendicular to the axis of the shank within 2°.

TABLE 11 HOLO-KROME HEXAGON AND SPLINE SOCKETS

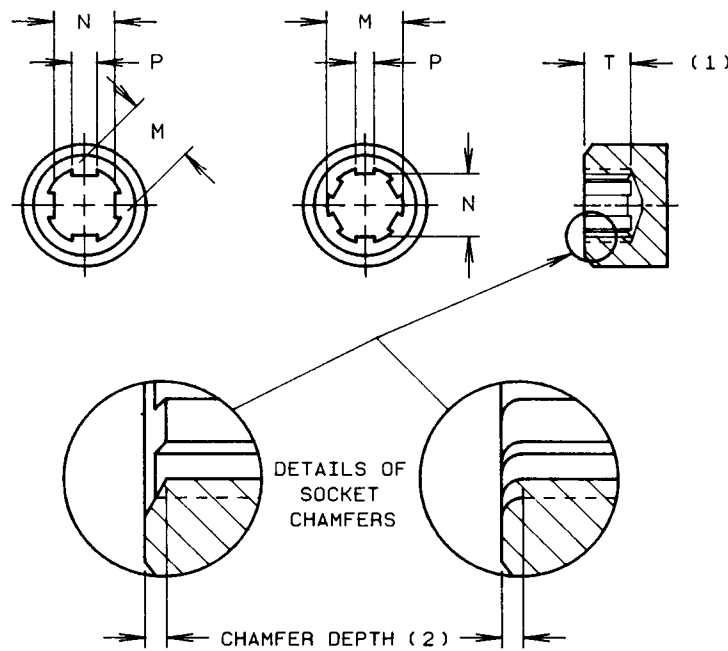
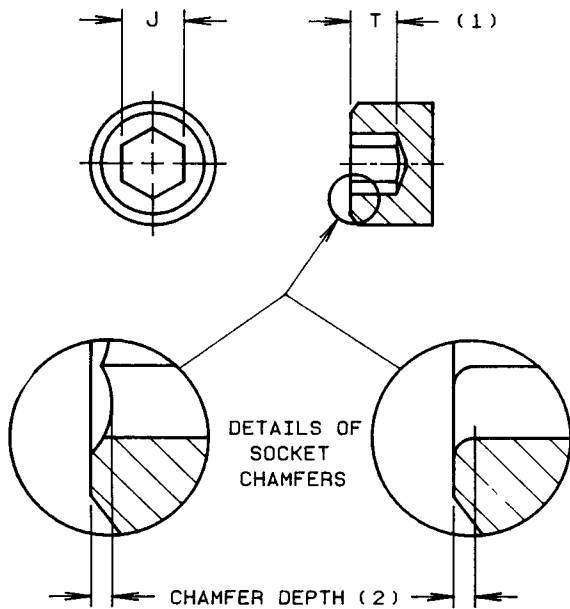

**TABLE 11 DIMENSIONS
HEXAGON**

NOMINAL SOCKET SIZE	J	
	SOCKET WIDTH ACROSS FLATS	
	MAX.	MIN.
0.028	0.0285	0.0280
0.035	0.0355	0.0350
0.050	0.0510	0.0500
1/16	0.0635	0.0625
5/64	0.0791	0.0781
5/32	0.0952	0.0937
7/64	0.1111	0.1094
1/8	0.1270	0.1250
9/64	0.1426	0.1406
5/32	0.1587	0.1562
3/16	0.1900	0.1875
7/32	0.2217	0.2187
1/4	0.2530	0.2500
5/16	0.3160	0.3125
3/8	0.3790	0.3750
7/16	0.4420	0.4375
1/2	0.5050	0.5000
9/16	0.5080	0.5625
5/8	0.6310	0.6250
3/4	0.7570	0.7500
7/8	0.8850	0.8750
1	1.0100	1.0000
1-1/4	1.2650	1.2500

SPLINE

NOMINAL SOCKET AND KEY SIZE	NUMBER OF TEETH	M		N		P	
		SOCKET MAJOR DIAMETER		SOCKET MINOR DIAMETER		WIDTH OF TOOTH	
		MAX.	MIN.	MAX.	MIN.	MAX.	MIN.
0.033	4	0.035	0.034	0.026	0.0255	0.012	0.0115
0.048	6	0.050	0.049	0.041	0.040	0.011	0.010
0.060	6	0.062	0.061	0.051	0.050	0.014	0.013
0.072	6	0.074	0.073	0.064	0.063	0.016	0.015
0.096	6	0.098	0.097	0.082	0.080	0.022	0.021
0.111	6	0.115	0.113	0.098	0.096	0.025	0.023
0.133	6	0.137	0.135	0.118	0.116	0.030	0.028
0.145	6	0.149	0.147	0.128	0.126	0.032	0.030
0.168	6	0.173	0.171	0.150	0.147	0.036	0.033
0.183	6	0.188	0.186	0.163	0.161	0.039	0.037
0.216	6	0.221	0.219	0.190	0.188	0.050	0.048
0.251	6	0.256	0.254	0.221	0.219	0.060	0.058
0.291	6	0.298	0.296	0.254	0.252	0.068	0.066
0.372	6	0.380	0.377	0.319	0.316	0.092	0.089
0.454	6	0.463	0.460	0.386	0.383	0.112	0.109
0.595	6	0.604	0.601	0.509	0.506	0.138	0.134
0.620	6	0.631	0.627	0.535	0.531	0.149	0.145
0.698	6	0.709	0.705	0.604	0.600	0.168	0.164
0.790	6	0.801	0.797	0.685	0.681	0.189	0.185

NOTE: Sockets up to 1" in nominal size should not be evaluated by direct measurement, but checked with go and no-go gages as specified in ASME/ANSI B18.3.

NOTES FOR TABLE 11

1. SOCKET DEPTH (T) - Applicable socket depths are specified in the dimensional tables and notes for the respective screw types.

2. SOCKET CHAMFER. Where hexagon sockets are chamfered, the depth of chamfer shall not exceed 10 per cent of the nominal socket size for sizes up to and including 1/16 in., and 7.5 per cent for larger sizes. For chamfered sockets, it is permissible for the NOT GO socket gage to enter to the dept of chamfer as specified in ASME/ANSI B 18.3.

TABLE 12 HOLO-KROME SOCKET HEAD SHOULDER SCREWS

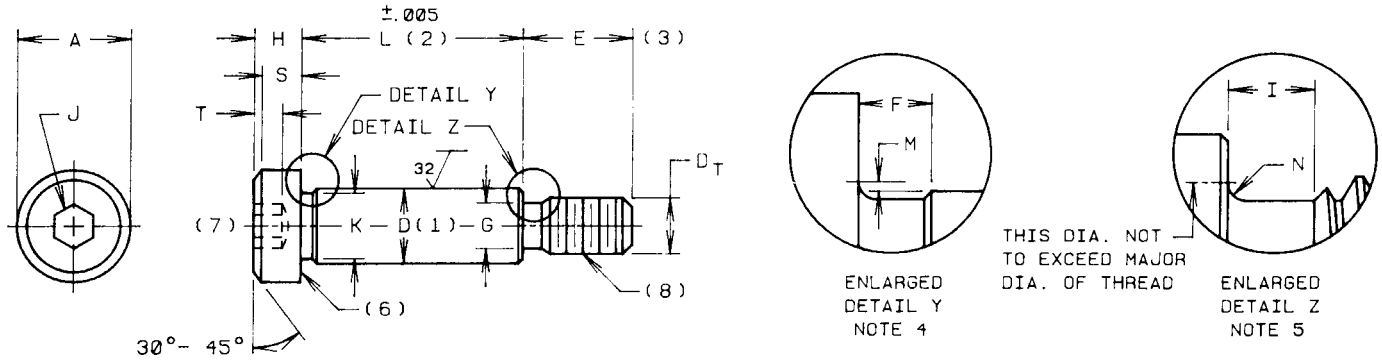

TABLE 12 DIMENSIONS

NOMINAL SIZE OR BASIC SHOULDER DIAMETER	D(1)		A		H		S	J		T	M		
	SHOULDER DIAMETER		HEAD DIAMETER		HEAD SIDE HEIGHT		HEAD HEIGHT	HEXAGON SOCKET SIZE		KEY ENGAGEMENT	HEAD FILLET EXTENSION ABOVE D		
	MAX.	MIN.	MAX.	MIN.	MAX.	MIN.	MIN.	NOM.		MIN.	MAX.	MIN.	
1/4	0.250	0.2480	0.2460	0.375	0.357	0.188	0.177	0.157	1/8	0.125	0.094	0.014	0.009
5/16	0.312	0.3105	0.3085	0.438	0.419	0.219	0.209	0.183	5/32	0.156	0.117	0.017	0.012
3/8	0.375	0.3730	0.3710	0.562	0.543	0.250	0.240	0.209	3/16	0.188	0.141	0.020	0.015
1/2	0.500	0.4980	0.4960	0.750	0.729	0.312	0.302	0.262	1/4	0.250	0.188	0.026	0.020
5/8	0.625	0.6230	0.6210	0.875	0.853	0.375	0.365	0.315	5/16	0.312	0.234	0.032	0.024
3/4	0.750	0.7480	0.7460	1.000	0.977	0.500	0.490	0.421	3/8	0.375	0.281	0.039	0.030
1	1.000	0.9980	0.9960	1.312	1.287	0.625	0.610	0.527	1/2	0.500	0.375	0.050	0.040
1-1/4	1.250	1.2480	1.2460	1.750	1.723	0.750	0.735	0.633	5/8	0.625	0.469	0.060	0.050
1-1/2	1.500	1.4980	1.4960	2.125	2.095	1.000	0.980	0.842	7/8	0.875	0.656	0.070	0.060
1-3/4	1.750	1.7480	1.7460	2.375	2.345	1.125	1.105	0.948	1	1.000	0.750	0.080	0.070
2	2.000	1.9980	1.9960	2.750	2.720	1.250	1.230	1.054	1-1/4	1.250	0.937	0.090	0.080

TABLE 12 DIMENSIONS (continued)

NOMINAL SIZE OR BASIC SHOULDER DIAMETER		K	F	D _T		THREADS PER INCH	G		I	N		E(3)
		SHOULDER NECK DIAMETER	SHOULDER NECK WIDTH	NOMINAL THREAD SIZE OR BASIC THREAD DIAMETER			THREAD NECK DIAMETER		THREAD NECK WIDTH	THREAD NECK FILLET		THREAD LENGTH
		MIN.	MAX.				MAX.	MIN.	MAX	MAX.	MIN.	BASIC
1/4	0.250	0.227	0.093	10	0.1900	24	0.142	0.133	0.083	0.023	0.017	0.375
5/16	0.312	0.289	0.093	1/4	0.2500	20	0.193	0.182	0.100	0.028	0.022	0.438
3/8	0.375	0.352	0.093	5/16	0.3125	18	0.249	0.237	0.111	0.031	0.025	0.500
1/2	0.500	0.477	0.093	3/8	0.3750	16	0.304	0.291	0.125	0.035	0.029	0.625
5/8	0.625	0.602	0.093	1/2	0.5000	13	0.414	0.397	0.154	0.042	0.036	0.750
3/4	0.750	0.727	0.093	5/8	0.6250	11	0.521	0.502	0.182	0.051	0.045	0.875
1	1.000	0.977	0.125	3/4	0.7500	10	0.638	0.616	0.200	0.055	0.049	1.000
1-1/4	1.250	1.227	0.125	7/8	0.8750	9	0.750	0.726	0.222	0.062	0.056	1.125
1-1/2	1.500	1.478	0.125	1-1/8	1.1250	7	0.964	0.934	0.286	0.072	0.066	1.500
1-3/4	1.750	1.728	0.125	1-1/4	1.2500	7	1.089	1.059	0.286	0.072	0.066	1.750
2	2.000	1.978	0.125	1-1/2	1.5000	6	1.307	1.277	0.333	0.102	0.096	2.000

HOLO-KROME SOCKET HEAD SHOULDER SCREWS



NOTES FOR TABLE 12

1. **SHOULDER.** Shoulder refers to the enlarged unthreaded portion of the screw, the diameter of which serves as the basis for derivation of the nominal size. The maximum shoulder diameter is 0.002 less than the nominal size.

2. **LENGTH.** The length of screw shall be measured parallel to the axis of screw from the plane of the bearing surface under the head to the plane of the shoulder at threaded end. The basic length dimension of the product shall be the nominal length of the shoulder, expressed as a three-place decimal.

STANDARD LENGTHS. The difference between consecutive lengths of standard screws shall be as designated in the following tabulation:

Nominal Screw (Shoulder) Length	Standard Length Increment
1/4 thru 3/4	1/8
3/4 thru 5	1/4
Over 5	1/2

3. **THREAD LENGTH TOLERANCE.** The tolerance on thread length E shall be -0.020 in. for screw sizes up to 3/8 in. inclusive, and -0.030 in. for screw sizes larger than 3/8 in.

4. **NECK AND FILLET UNDER HEAD.** The screws may be necked under the head at option of Holo-Krome. The fillet at the intersection of the head bearing surface and neck or shoulder shall be above D within the tabulated limits for M.

5. **NECK UNDER SHOULDER.** The neck under the shoulder shall allow the shoulder to seat against the face of a standard basic GO thread ring gage.

6. **BEARING SURFACE.** The plane of the bearing surface of the head shall be perpendicular to the axis of the shoulder within a maximum deviation of two degrees.

7. **CONCENTRICITY.** Head shall be concentric with the shoulder within 1 per cent (2 per cent total runout) of the nominal diameter D or 0.003 in. (0.006 in. total runout), whichever is greater.

Pitch diameter and shoulder shall be concentric within 0.004 in. total runout when checked at a distance of 0.188 in. from the shoulder at the threaded end.

Concentricity, parallelism, bow and squareness of shoulder to thread, shall be within 0.005 in. total runout per inch of shoulder length, with a maximum of 0.025 in., when firmly seated against the shoulder in a threaded bushing, and checked on the shoulder a distance 2F from the underside of the head. Threads of bushing shall be basic size, and bushing OD and ends shall be concentric and square with the axis.

8. **THREADS AND GAGING.** Threads are Class 3A UNRC and UNRF with Holo-Krome controlled radius root. Acceptability of screw threads shall be based on System 22 of ANSI/ASME B1.3M.

Class 3A threads do not provide a plating allowance. When plating is required, it is recommended that Holo-Krome supply the parts plated.

Applicable Standards and Specifications
ASME/ANSI B18.3

TABLE 13 HOLO-KROME SOCKET SET SCREWS

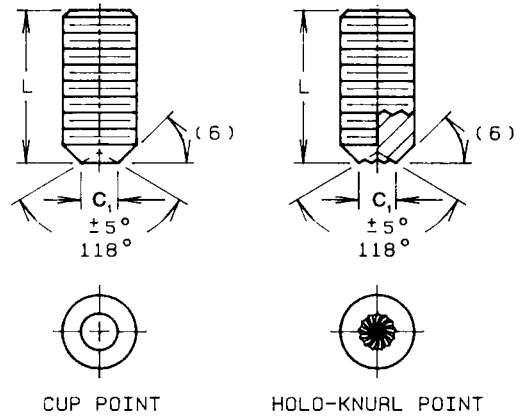
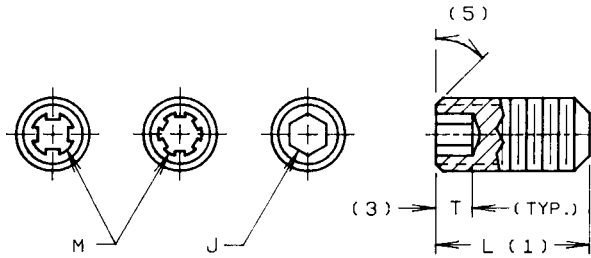

TABLE 13 DIMENSIONS

NOMINAL SIZE	BASIC SCREW DIAMETER	J(4)		M(4)	T (3)		C ₁		C ₂		R	Y
		HEXAGON SOCKET SIZE		SPLINE SOCKET SIZE	MIN KEY ENGAGEMENT TO DEVELOP FUNCTIONAL CAPABILITY OF KEY		CUP POINT DIAMETERS		FLAT POINT DIAMETERS		OVAL POINT RADIUS	CONE POINT ANGLE 90° ±2° FOR THESE NOMINAL LENGTHS OR LONGER: 118° ±2° FOR SHORTER NOMINAL LENGTHS
		NOM.	NOM.	HEX SOCKET T _H MIN.	SPLINE SOCKET T _S MIN.	MAX.	MIN.	MAX.	MIN.	BASIC		
0	0.0600	0.028	0.033	0.050	0.026	0.032	0.027	0.033	0.027	0.045	0.09	
1	0.0730	0.035	0.033	0.060	0.035	0.038	0.033	0.040	0.033	0.055	0.09	
2	0.0860	0.035	0.048	0.060	0.040	0.043	0.038	0.047	0.039	0.064	0.13	
3	0.0990	0.050	0.048	0.070	0.040	0.050	0.045	0.054	0.045	0.074	0.13	
4	0.1120	0.050	0.060	0.070	0.045	0.056	0.051	0.061	0.051	0.084	0.19	
5	0.1250	1/16 0.062	0.072	0.080	0.055	0.062	0.056	0.067	0.057	0.094	0.19	
6	0.1380	1/16 0.062	0.072	0.080	0.055	0.069	0.062	0.074	0.064	0.104	0.19	
8	0.1640	5/64 0.078	0.096	0.090	0.080	0.082	0.074	0.087	0.076	0.123	0.25	
10	0.1900	3/32 0.094	0.111	0.100	0.080	0.095	0.086	0.102	0.088	0.142	0.25	
1/4	0.2500	1/8 0.125	0.145	0.125	0.125	0.125	0.114	0.132	0.118	0.188	0.31	
5/16	0.3125	5/32 0.156	0.183	0.156	0.156	0.156	0.144	0.172	0.156	0.234	0.38	
3/8	0.3750	3/16 0.188	0.216	0.188	0.188	0.187	0.174	0.212	0.194	0.281	0.44	
7/16	0.4375	7/32 0.219	0.251	0.219	0.219	0.218	0.204	0.252	0.232	0.328	0.50	
1/2	0.5000	1/4 0.250	0.291	0.250	0.250	0.250	0.235	0.291	0.270	0.375	0.57	
5/8	0.6250	5/16 0.312	0.372	0.312	0.312	0.312	0.295	0.371	0.347	0.469	0.75	
3/4	0.7500	3/8 0.375	0.454	0.375	0.375	0.375	0.357	0.450	0.425	0.562	0.88	
7/8	0.8750	1/2 0.500	0.595	0.500	0.500	0.437	0.418	0.530	0.502	0.656	1.00	
1	1.0000	9/16 0.562	—	0.562	—	0.500	0.480	0.609	0.579	0.750	1.13	

NOTES FOR TABLE 13

1. LENGTH - The length of the screw shall be measured overall, parallel to axis of screw. The basic length dimension on the product shall be the nominal length expressed as a two-place decimal.

STANDARD LENGTH INCREMENTS, L

NOMINAL SCREW LENGTH	STANDARD LENGTH INCREMENT
1/16 thru 3/16*	.03
1/8 thru 1/2	.06
1/2 thru 1	.12
1 thru 2	.25
2 thru 6	.50
Over 6	1.00

* Applicable only to sizes 0 (0.060 in.) through 3 (0.099 in.), inclusive.

LENGTH TOLERANCES, L

NOMINAL SCREW LENGTH	TOLERANCE ON LENGTH
Up to 5/8, Incl..	± 0.01
Over 5/8 to 2, Incl.	± 0.02
Over 2 to 6, Incl.	± 0.03
Over 6	± 0.06

2. THREADS AND GAGING. Threads shall be Unified external thread; Class 3A, UNC and UNF Series. Acceptability of screw threads shall be based on System 22 of ANSI/ASME B1.3M.

Since standard gages provide only for engagement lengths up to 1-1/2 diameters, changes in pitch diameter of either or both external and internal thread may be required for longer lengths of engagement.

Class 3A does not provide a plating allowance. When plated products are required, it is recommended that Holo-Krome supply the parts plated.

3. SOCKET DEPTHS. The key engagement dimensions given in columns T_H and T_S of Table 13 shall apply only to nominal screw lengths equal to or longer than the lengths listed in Columns B and B₁, respectively. For hexagon socket key engagement dimensions in screws of shorter nominal lengths than listed in Column B of Table 13, see Table 14. Spline sockets in screws shorter than those listed in Column B₁ of Table 13 shall be as deep as practicable.

4. SOCKETS. Thermo-Forging®, a Holo-Krome patented process, provides accurately formed sockets without broaching chips. Because Thermo-Forging is not a machining process, it does not shear metal grains and the sockets can be deeper and much stronger.

HOLO-KROME SOCKET SET SCREWS

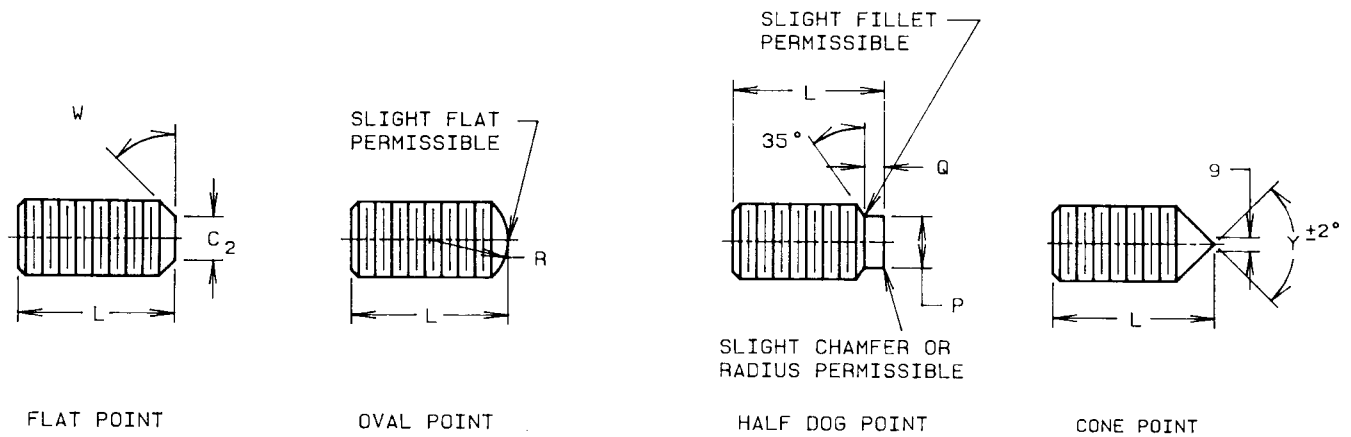

TABLE 13 DIMENSIONS (Continued)

NOMINAL SIZE	BASIC SCREW DIAMETER	P		Q		B			B ₁		
		HALF DOG POINT				SHORTEST OPTIMUM NOMINAL LENGTH TO WHICH COLUMN T _H APPLIES			SHORTEST OPTIMUM NOMINAL LENGTH TO WHICH COLUMN T _S APPLIES		
		DIAMETER		LENGTH		CUP AND FLAT POINTS	90° CONE AND OVAL POINTS	HALF DOG POINTS	CUP AND FLAT POINTS	90° CONE AND OVAL POINTS	HALF DOG POINTS
		MAX.	MIN.	MAX.	MIN.						
0	0.0600	0.040	0.037	0.017	0.013	0.13	0.13	0.13	0.06	0.13	0.13
1	0.0730	0.049	0.045	0.021	0.017	0.13	0.19	0.13	0.13	0.19	0.13
2	0.0860	0.057	0.053	0.024	0.020	0.13	0.19	0.19	0.13	0.19	0.19
3	0.0990	0.066	0.062	0.027	0.023	0.19	0.19	0.19	0.13	0.19	0.19
4	0.1120	0.075	0.070	0.030	0.026	0.19	0.19	0.19	0.13	0.19	0.19
5	0.1250	0.083	0.078	0.033	0.027	0.19	0.19	0.19	0.13	0.19	0.19
6	0.1380	0.092	0.087	0.038	0.032	0.19	0.25	0.19	0.13	0.25	0.19
8	0.1640	0.109	0.103	0.043	0.037	0.19	0.25	0.25	0.19	0.25	0.25
10	0.1900	0.127	0.120	0.049	0.041	0.19	0.25	0.25	0.19	0.25	0.25
1/4	0.2500	0.156	0.149	0.067	0.059	0.25	0.31	0.31	0.25	0.31	0.31
5/16	0.3125	0.203	0.195	0.082	0.074	0.31	0.44	0.38	0.31	0.44	0.38
3/8	0.3750	0.250	0.241	0.099	0.089	0.38	0.44	0.44	0.38	0.44	0.44
7/16	0.4375	0.297	0.287	0.114	0.104	0.44	0.63	0.50	0.44	0.63	0.50
1/2	0.5000	0.344	0.334	0.130	0.120	0.50	0.63	0.63	0.50	0.63	0.63
5/8	0.6250	0.469	0.456	0.164	0.148	0.63	0.88	0.88	0.63	0.88	0.88
3/4	0.7500	0.562	0.549	0.196	0.180	0.75	1.00	1.00	0.75	1.00	1.00
7/8	0.8750	0.656	0.642	0.227	0.211	0.88	1.00	1.00	0.88	1.25	1.00
1	1.0000	0.750	0.734	0.260	0.240	1.00	1.25	1.25	—	—	—

5. CHAMFER. On screws longer than minimum lengths listed in Column B or B₁, the face will normally be chamfered between 30° and 45°. Shorter screws will be chamfered where possible.

In special applications where stripping is a problem, Holo-Krome may be able to supply unchamfered screws to provide additional strength.

6. POINT ANGLE. The angle on flat and cup point set screws is 45° plus 5° minus 0° for screws of lengths equal to or longer than those listed in Column B or B₁; and 30° minimum for shorter screws.

The point angle applies only to that portion of the angle below the thread root diameter.

7. OVAL POINT. The oval point radius tolerance is + 0.015 inches for

nominal sizes through 5, and + 0.031 inches for screws 6 and over.

8. HALF DOG POINT ECCENTRICITY. The permissible eccentricity of the half dog axis, with respect to the axis of the thread, shall not exceed 3 per cent of the basic diameter of the screw, and in no case shall be greater than 0.005 in. for sizes up to and incl. 3/4 in. For sizes over 3/4 in. it shall not be greater than 0.010 in. (Total runout shall not exceed twice the permissible eccentricity.)

9. CONE POINT CONFIGURATION. The apex of the cone may be flattened or rounded to the extent of 10 per cent of the basic diameter of the screw.

Applicable Standards and Specifications
ASME/ANSI B18.3 and ASTM F912.

TABLE 14 HOLO-KROME SOCKET SET SCREWS

TABLE 14 HEXAGON KEY ENGAGEMENTS FOR SHORT LENGTH SET SCREWS^{1, 2}

NOMINAL SIZE	BASIC SCREW DIAMETER	J		L NOMINAL SCREW LENGTHS ¹	T _H MINIMUM KEY ENGAGEMENT		
		HEXAGON SOCKET SIZE			CUP ⁶ AND FLAT POINTS	118° CONE AND OVAL POINTS	HALF DOG POINT
		NOM.					
0	0.0600	0.028		0.06 0.09	0.030 0.040	0.028 0.040 ⁵	— ⁴ 0.028
1	0.0730	0.035		0.06 0.09	0.030 0.040	0.029 0.040 ⁵	— ⁴ 0.040
2	0.0860	0.035		0.06 0.09	0.030 0.040	0.029 0.040	— ⁴ 0.035
3	0.0990	0.050		0.09 0.13	0.040 0.055	0.039 0.040 ⁵	— ⁴ 0.045
4	0.1120	0.050		0.09 0.13	0.045 0.060	0.039 0.045	— ⁴ 0.045
5	0.1250	1/16	0.062	0.09 0.13	0.040 0.060	0.039 0.045	— ⁴ 0.045
6	0.1380	1/16	0.062	0.09 0.13 0.16	0.040 0.060 0.070	0.039 0.045 0.065	— ⁴ 0.045 0.065
8	0.1640	5/64	0.078	0.13 0.16 0.19	0.060 0.070 — ³	0.050 0.060 0.065	0.045 0.060 0.065
10	0.1900	3/32	0.094	0.13 0.19	0.060 — ³	0.042 0.060	0.042 0.060
1/4	0.2500	1/8	0.125	0.19 0.25	0.090 — ³	0.065 0.110	0.055 0.090
5/16	0.3125	5/32	0.156	0.25 0.31	0.125 — ³	0.099 0.140	0.090 0.105
3/8	0.3750	3/16	0.188	0.25 0.31 0.50	0.110 0.140 — ³	0.090 0.115 0.165	0.075 0.105 0.155
7/16	0.4375	7/32	0.219	0.38 0.44	0.160 — ³	0.125 0.160	0.125 0.160
1/2	0.5000	1/4	0.250	0.38 0.44 0.50	0.175 0.215 — ³	0.130 0.155 0.195	0.130 0.155 0.195
5/8	0.6250	5/16	0.312	0.50	0.205	0.145	0.145
3/4	0.7500	3/8	0.375	0.63 0.75	0.255 — ³	0.190 0.325	0.190 0.295
7/8	0.8750	1/2	0.500	0.75 0.87	0.330 — ³	0.255 0.419	0.225 0.330
1	1.0000	9/16	0.562	0.75 0.85 1.00	0.280 0.380 — ³	0.175 0.280 0.380	0.175 0.280 0.380

¹CAUTION: The use of products listed in Table 14 can result in failure of the socket key, or mating threads during tightening because key engagement and thread length are less than optimum. Therefore, it is strongly recommended that screws of lengths equal to or greater than the lengths specified in Columns B and B₁ of Table 13 be used wherever possible.

²See Table 13 and the illustrations and notes thereto, for additional dimensions and specifications.

³These products are covered in Table 13.

⁴These sizes are impractical to manufacture because of point configuration and short length.

⁵Cone point angle for these lengths shall be 90°; see Column Y in Table 13.

⁶Cup angle may be 118° or 130°, ± 5°, depending upon screw length and manufacturing process.

TABLE 15 HOLO-KROME DOWEL PINS

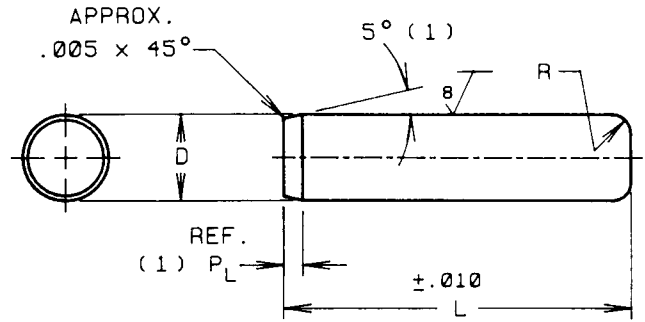

TABLE 15 DIMENSIONS

NOMINAL SIZE	DIAMETER D				P _L POINT LENGTH (REF.)	R TOP RADIUS BASIC
	STANDARD PIN		OVERSIZE PIN			
	MAX.	MIN.	MAX.	MIN.		
1/8	0.1253	0.1251	0.1261	0.1259	0.045	0.031
3/16	0.1878	0.1876	0.1886	0.1884	0.060	0.046
1/4	0.2503	0.2501	0.2511	0.2509	0.070	0.062
5/16	0.3128	0.3126	0.3136	0.3134	0.070	0.062
3/8	0.3753	0.3751	0.3761	0.3759	0.080	0.078
7/16	0.4378	0.4376	0.4386	0.4384	0.090	0.093
1/2	0.5003	0.5001	0.5011	0.5009	0.090	0.109
5/8	0.6253	0.6251	0.6261	0.6259	0.090	0.125
3/4	0.7503	0.7501	0.7511	0.7509	0.120	0.125
7/8	0.8753	0.8751	0.8761	0.8759	0.120	0.125
1	1.0003	1.0001	1.0011	1.0009	0.120	0.125

1. Point length is decreased and point angle increased on short dowel pins.

Applicable Standards and Specifications
ASME/ANSI B18.8.2

TABLE 16 HOLO-KROME PULL DOWEL PINS

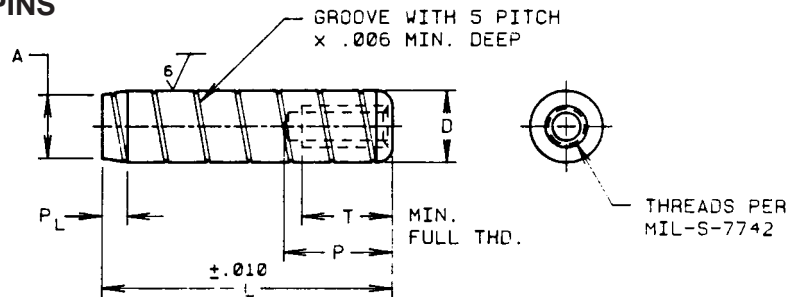

TABLE 16 DIMENSIONS

NOMINAL SIZE	THREAD SIZE	A	D		P _L	P	T
		MAX.	MAX.	MIN.	MIN.	MAX.	MIN.
1/4	#8-32 UNC-2B	0.237	0.2503	0.2501	0.031	0.500	0.250
5/16	#10-32 UNF-2B	0.298	0.3128	0.3126	0.034	0.625	0.344
3/8	#10-32 UNF-2B	0.359	0.3753	0.3751	0.038	0.625	0.344
7/16	#10-32 UNF-2B	0.417	0.4378	0.4376	0.047	0.625	0.344
1/2	1/4-20 UNC-2B	0.480	0.5003	0.5001	0.047	0.750	0.375
5/8	1/4-20 UNC-2B	0.605	0.6253	0.6251	0.047	0.750	0.375
3/4	5/16-18 UNC-2B	0.725	0.7503	0.7501	0.059	0.875	0.375
7/8	3/8-16 UNC-2B	0.850	0.8753	0.8751	0.059	0.875	0.375
1	3/8-16 UNC-2B	0.975	1.0003	1.0001	0.059	0.875	0.375

Applicable Standards and Specifications
ASME/ANSI B18.8.2.

TABLE 17 ALLEN WRENCHES AND BITS

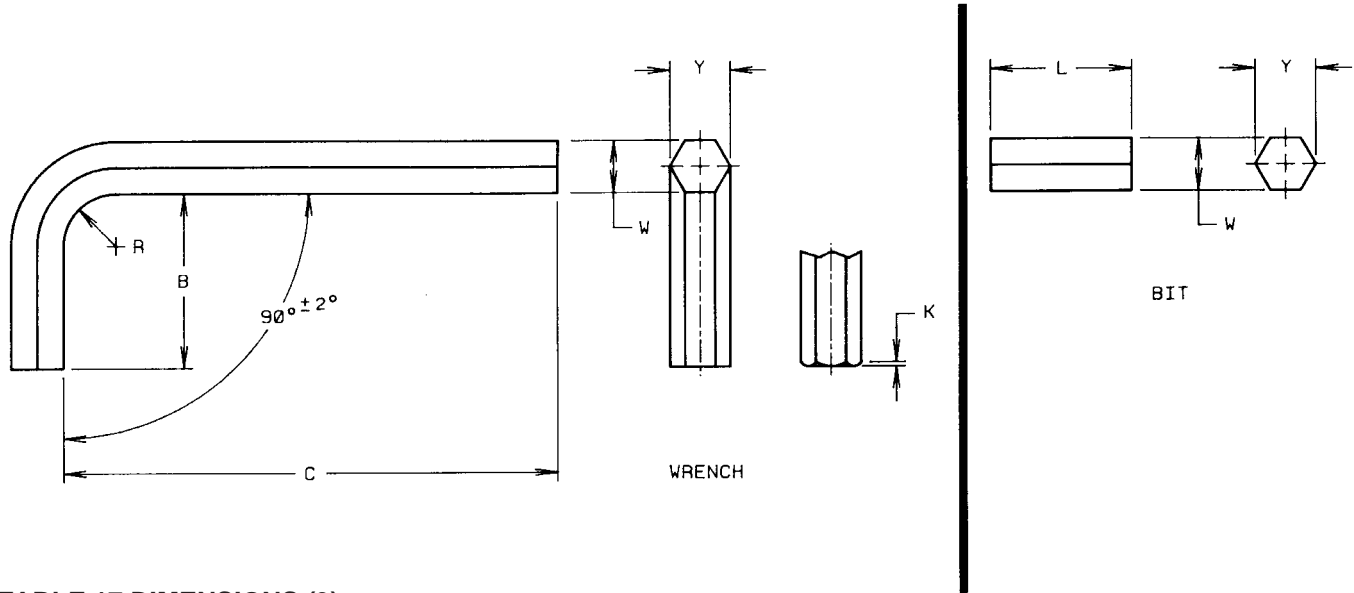

TABLE 17 DIMENSIONS (3)

NOMINAL KEY OR BIT AND SOCKET SIZE	W		Y		B		C				R	K
	HEXAGON WIDTH ACROSS FLATS		HEXAGON WIDTH ACROSS CORNERS		LENGTH OF SHORT ARM		LENGTH OF LONG ARM				RADIUS OF BEND	CHAMFER
	MAX.	MIN.	MAX.	MIN.	MAX.	MIN.	SHORT SERIES		LONG SERIES			
							MAX.	MIN.	MAX.	MIN.	MIN.	MAX.
0.028	0.0280	0.0275	0.0314	0.0300	0.312	0.125	1.312	1.125	2.688	2.500	0.062	0.003
0.035	0.0350	0.0345	0.0393	0.0378	0.438	0.250	1.312	1.125	2.766	2.578	0.062	0.004
0.050	0.0500	0.0490	0.0560	0.0540	0.625	0.438	1.750	1.562	2.938	2.750	0.062	0.006
1/16 0.062	0.0625	0.0615	0.0701	0.0680	0.656	0.469	1.844	1.656	3.094	2.906	0.062	0.008
5/64 0.078	0.0781	0.0771	0.0880	0.0859	0.703	0.516	1.969	1.781	3.281	3.094	0.078	0.008
3/32 0.094	0.0937	0.0927	0.1058	0.1035	0.750	0.562	2.094	1.906	3.469	3.281	0.094	0.009
7/64 0.109	0.1094	0.1079	0.1238	0.1210	0.797	0.609	2.219	2.031	3.656	3.469	0.109	0.014
1/8 0.125	0.1250	0.1235	0.1418	0.1390	0.844	0.656	2.344	2.156	3.844	3.656	0.125	0.015
9/64 0.141	0.1406	0.1391	0.1593	0.1566	0.891	0.703	2.469	2.281	4.031	3.844	0.141	0.016
5/32 0.156	0.1562	0.1547	0.1774	0.1745	0.938	0.750	2.594	2.406	4.219	4.031	0.156	0.016
3/16 0.188	0.1875	0.1860	0.2135	0.2105	1.031	0.844	2.844	2.656	4.594	4.406	0.188	0.022
7/32 0.219	0.2187	0.2172	0.2490	0.2460	1.125	0.938	3.094	2.906	4.969	4.781	0.219	0.024
1/4 0.250	0.2500	0.2485	0.2845	0.2815	1.219	1.031	3.344	3.156	5.344	5.156	0.250	0.030
5/16 0.312	0.3125	0.3110	0.3570	0.3531	1.344	1.156	3.844	3.656	6.094	5.906	0.312	0.032
3/8 0.375	0.3750	0.3735	0.4300	0.4238	1.469	1.281	4.344	4.156	6.844	6.656	0.375	0.044
7/16 0.438	0.4375	0.4355	0.5018	0.4944	1.594	1.406	4.844	4.656	7.594	7.406	0.438	0.047
1/2 0.500	0.5000	0.4975	0.5735	0.5650	1.719	1.531	5.344	5.156	8.344	8.156	0.500	0.050
9/16 0.562	0.5625	0.5600	0.6452	0.6356	1.844	1.656	5.844	5.656	9.094	8.906	0.562	0.053
5/8 0.625	0.6250	0.6225	0.7169	0.7080	1.969	1.781	6.344	6.156	9.844	9.656	0.625	0.055
3/4 0.750	0.7500	0.7470	0.8603	0.8512	2.219	2.031	7.344	7.156	11.344	11.156	0.750	0.070
7/8 0.875	0.8750	0.8720	1.0036	0.9931	2.469	2.281	8.344	8.156	12.844	12.656	0.875	0.076
1 1.000	1.0000	0.9970	1.1470	1.1350	2.719	2.531	9.344	9.156	14.344	14.156	1.000	0.081
1-1/4 1.250	1.2500	1.2430	—	—	3.250	2.750	11.500	11.000	—	—	1.250	0.092
1-1/2 1.500	1.5000	1.4930	—	—	3.750	3.250	13.500	13.000	—	—	1.500	0.104

1. Each end is square with the axis of each arm within 4° and edges may be sharp or chamfered at the option of Holo-Krome, the chamfer not to exceed K.

2. For nominal socket sizes above 1 in. it is recommended that bits be used in conjunction with standard hexagon wrenches or power drives. Bits are available, but lengths are not standardized.

3. For plated wrenches and bits, all dimensions are before plating.

Applicable Standards and Specifications
ASME/ANSI B18.3 and GGG-K-275 Amend. 1 (Reference)

TABLE 18 ALLEN SPLINE KEYS AND BITS

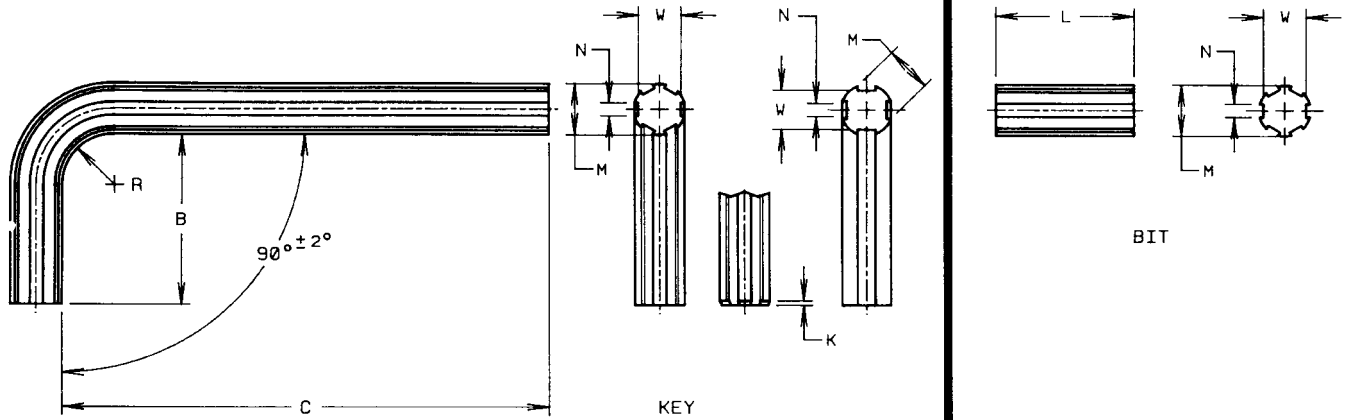

TABLE 18 DIMENSIONS (2)

NOMINAL KEY OR BIT AND SOCKET SIZE	M		W		NO. OF SPLINES	N		B		C				R RADIUS OF BEND	K CHAMFER
	MAJOR DIAMETER		MINOR DIAMETER			WIDTH OF SPACE		LENGTH OF SHORT ARM		LENGTH OF LONG ARM					
	MAX.	MIN.	MAX.	MIN.		MAX.	MIN.	MAX.	MIN.	MAX.	MIN.	MAX.	MIN.	MAX.	MIN.
0.033	0.0330	0.0320	0.0250	0.0240	4	0.0140	0.0130	0.312	0.125	1.312	1.125	—	—	0.062	0.003
0.048	0.0480	0.0470	0.0390	0.0380	6	0.0130	0.0120	0.438	0.250	1.312	1.125	—	—	0.062	0.004
0.060	0.0600	0.0590	0.0490	0.0480	6	0.0160	0.0150	0.625	0.438	1.750	1.562	—	—	0.062	0.006
0.072	0.0720	0.0710	0.0620	0.0610	6	0.0190	0.0180	0.656	0.469	1.844	1.656	—	—	0.062	0.008
0.096	0.0960	0.0950	0.0790	0.0775	6	0.0240	0.0230	0.703	0.516	1.969	1.781	—	—	0.078	0.008
0.111	0.1110	0.1100	0.0940	0.0925	6	0.0280	0.0270	0.750	0.562	2.094	1.906	—	—	0.094	0.009
0.133	0.1330	0.1310	0.1140	0.1120	6	0.0340	0.0320	0.797	0.609	2.219	2.031	3.656	3.469	0.125	0.014
0.145	0.1450	0.1435	0.1240	0.1225	6	0.0355	0.0340	0.844	0.656	2.344	2.156	3.844	3.656	0.125	0.015
0.168	0.1680	0.1660	0.1440	0.1420	6	0.0410	0.0390	0.891	0.703	2.469	2.281	4.031	3.844	0.156	0.016
0.183	0.1830	0.1815	0.1580	0.1565	6	0.0440	0.0425	0.938	0.750	2.594	2.406	4.219	4.031	0.156	0.016
0.216	0.2160	0.2145	0.1840	0.1825	6	0.0550	0.0535	1.031	0.844	2.844	2.656	4.594	4.406	0.188	0.022
0.251	0.2510	0.2495	0.2140	0.2125	6	0.0655	0.0640	1.125	0.938	3.094	2.906	4.969	4.781	0.219	0.024
0.291	0.2910	0.2895	0.2460	0.2445	6	0.0775	0.0760	1.219	1.031	3.344	3.156	5.344	5.156	0.250	0.030
.372	.3720	.3705	.3100	.3085	6	.0975	.0960	1.344	1.156	3.844	3.656	6.094	5.906	0.312	0.032
.454	.4540	.4525	.3770	.3755	6	.1185	.1170	1.469	1.281	4.344	4.156	6.844	6.656	0.375	0.044
.595	.5950	.5935	.5000	.4975	6	.1460	.1445	1.719	1.531	5.344	5.156	8.344	8.156	0.500	0.050
.620	.6200	.6175	.5240	.5215	6	.1615	.1590	1.844	1.656	5.844	5.656	9.094	8.906	0.500	0.053
.698	.6980	.6955	.5930	.5905	6	.1805	.1780	1.844	1.656	5.844	5.656	—	—	0.562	0.055
.790	.7900	.7875	.6740	.6715	6	.1975	.1950	1.969	1.781	6.344	6.156	—	—	0.625	0.070

1. Each end is square with the axis of each arm within 4° and edges may be sharp or chamfered at the option of Holo-Krome, the chamfer not to exceed K.

2. For plated keys and bits, all dimensions are before plating.

3. Bits are available, but lengths have not been standardized.

Applicable Standards and Specifications

ASME/ANSI B18.3 and GGG-K-275 Amend. 1 (Reference)

TABLE 19 HOLO-KROME SOCKET PRESSURE PLUGS — DRYSEAL (NPTF) TYPE — 3/4 TAPER

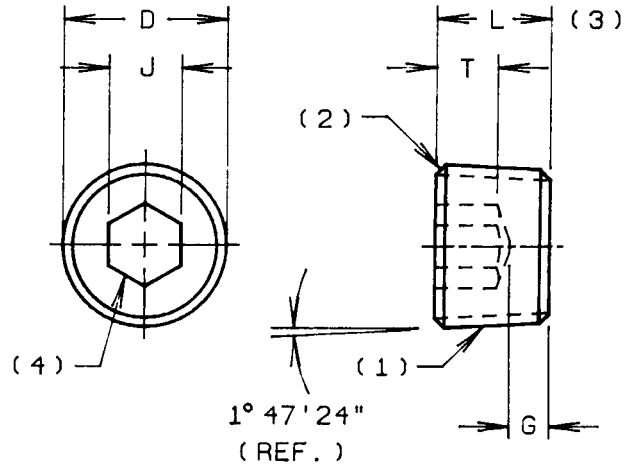

HOLO-KROME HEXAGON SOCKET PRESSURE PLUGS — DRYSEAL (NPTF) — The Holo-Krome Dryseal Pressure Plug is a plug that has a tapered (3/4 inch diametral per foot) thread extending its entire length and is designed to have its threads mesh tightly with those of a taper-threaded hole. The thread truncation is closely controlled at root and crest to ensure metal-to-metal contact at these points,

coincident to or prior to flank contact. This prevents spiral leakage and provides more positive sealing. Holo-Krome Dryseal NPTF pressure plugs can be used in NPT tapped holes, but for best protection against leakage they should be used in dryseal tapped holes that are taper reamed before tapping.

TABLE 19 DIMENSIONS — DRYSEAL TYPE — 3/4 TAPER

NOMINAL SIZE	D		J		T	G	L (3)		
	NOMINAL O.D.	THREADS PER INCH	HEX SOCKET SIZE		KEY ENGAGEMENT MIN.	WALL THICKNESS MIN.	LENGTH		
			NOM.				NOM.	MAX.	MIN.
1/16	.312	27	5/32	0.156	0.140	0.062	0.312	0.324	0.300
1/8	.405	27	3/16	0.187	0.140	0.062	0.312	0.324	0.300
1/4	.540	18	1/4	0.250	0.218	0.073	0.438	0.457	0.417
3/8	.675	18	5/16	0.312	0.250	0.084	0.500	0.520	0.480
1/2	.840	14	3/8	0.375	0.312	0.095	0.562	0.582	0.542
3/4	1.050	14	9/16	0.562	0.312	0.125	0.625	0.645	0.605
1	1.315	11-1/2	5/8	0.625	0.375	0.125	0.750	0.770	0.730
1-1/4	1.660	11-1/2	3/4	0.750	0.437	0.156	0.812	0.832	0.792
1-1/2	1.900	11-1/2	1	1.000	0.437	0.156	0.812	0.843	0.780
2	2.375	11-1/2	1	1.000	0.437	0.156	0.875	0.906	0.844

NOTES FOR TABLE 19

- 1. THREADS** - Threads conform to the American Standard Taper Dryseal Pipe Thread NPTF in accordance with specifications and gaging requirements described in ANSI B2.2.
- 2. THREAD CHAMFERS** - Both ends of the plug shall be flat and chamfered approximately 90° angle included. The chamfer shall extend slightly below the root of the thread, and the edge between the flat and the chamfer may be slightly rounded.
- 3. LENGTH** - The length of the plug shall be measured overall on a line parallel to the axis.
- 4. SOCKETS** - See Page 13 Table 11, for hexagon socket dimensions. A slight chamfer, radius or countersink on the hexagon socket is permissible.

5. DESIGNATION - Each of the letters in the symbol has a definite significance as follows:

- N = USA (American) Standard
- P = Pipe
- T = Taper
- F = Fuel and Oil
- 3/4 = 0.750 inch taper per 12 inches

Applicable Standards and Specifications
ANSI B2.2 and ANSI B1.20.3

TABLE 20 HOLO-KROME SOCKET PRESSURE PLUGS — FLUSH (PTF) TYPE — 7/8 TAPER

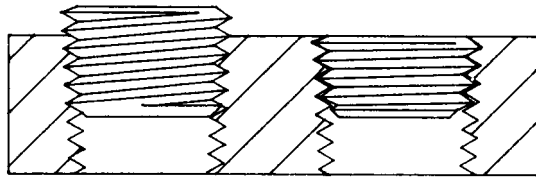

NPTF VS. PTF

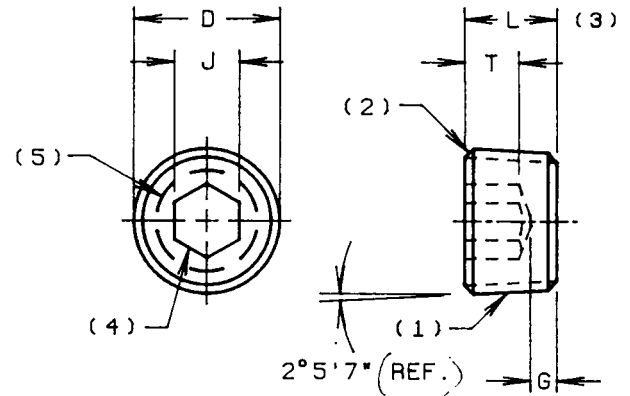

HOLO-KROME HEXAGON SOCKET PRESSURE PLUGS — FLUSH TYPE (PTF — 7/8). The Holo-Krome flush type plug is a plug having a tapered thread (7/8" diametral per foot) extending its entire length and designed to provide a flush condition with a standard taper-tapped hole

(3/4" diametral per foot). It achieves a high pressure seal through the difference in taper, with dimensions precalculated to provide a higher sealing load near the large end of the plug and the threads near the top of the tapped hole. It is used in applications where high pressures are encountered and where protrusion is undesirable.

TABLE 20 DIMENSIONS — FLUSH TYPE — 7/8 TAPER

NOMINAL SIZE	D	THREADS PER INCH	J		T	G	L (3)		BASIC PITCH DIAMETER AT SOCKET FACE
	NOMINAL O.D.		HEX SOCKET SIZE		KEY ENGAGEMENT	WALL THICKNESS	OVERALL LENGTH		
			NOM.	MIN.	MIN.	MAX.	MIN.		
1/16	0.307	27	5/32	0.156	0.140	0.052	0.250	0.235	0.28253
1/8	0.401	27	3/16	0.187	0.140	0.049	0.250	0.235	0.37495
1/4	0.529	18	1/4	0.250	0.218	0.045	0.406	0.391	0.49366
3/8	0.667	18	5/16	0.312	0.250	0.040	0.406	0.391	0.62904
1/2	0.830	14	3/8	0.375	0.312	0.067	0.531	0.516	0.78103
3/4	1.041	14	9/16	0.562	0.312	0.054	0.531	0.516	0.99147

NOTES FOR TABLE 20

1. THREADS - Threads conform to ANSI B2.2 Dryseal Taper Pipe Thread. Taper: 7/8" diametral per foot.

PITCH DIAMETER - The pitch diameter at the socket face is the diametral equivalent of one-half thread larger than the pitch diameter (E₁) of a standard pipe thread taper-tapped hole (3/4 diametral taper per foot). This provides the basic point of thread interference to produce a high pressure sealed joint.

2. THREAD CHAMFERS - Both ends of the plug shall be flat and chamfered approximately 90° included; the chamfer shall extend slightly below the root of the thread and the edge between flat and chamfer may be slightly rounded.

3. LENGTH - The length of the plug shall be measured overall on a line parallel to the axis.

4. SOCKETS - See Page 13 Table 11, for hexagon socket dimensions. A slight chamfer, radius or countersink on hexagon sockets is permissible.

5. IDENTIFICATION GROOVES - Six equally spaced identification grooves are located equidistant between corners of hexagon socket and edge of chamfer with no particular alignment with hexagon. On 1/16 - 27 plugs, three identification grooves are permitted because of space limitations.

6. DESIGNATION - Each of the characters in the symbol has a definite significance as follows:

- P = Plug
- T = Taper
- F = Flush
- 7/8 = .875 inch taper per 12 inches

Applicable Standards and Specifications
ANSI B2.2

TABLE 21 HOLO-KROME SOCKET JAM SCREWS

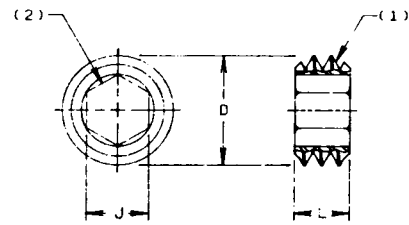

TABLE 21 DIMENSIONS

NOMINAL SIZE	BASIC SCREW DIAMETER	J		L		
		NOM. SOCKET SIZE		LENGTH		
		NOMINAL	MAX.	NOMINAL	MAX.	MIN.
4	0.1120	0.050		0.078	0.088	0.068
5	0.1250	1/16	0.062	0.094	0.103	0.083
6	0.1380	1/16	0.062	0.094	0.103	0.083
8	0.1640	5/64	0.078	0.109	0.119	0.099
10	0.1900	3/32	0.094	0.125	0.135	0.115
1/4	0.2500	1/8	0.125	0.125	0.135	0.115
5/16	0.3125	5/32	0.156	0.156	0.166	0.146
3/8	0.3750	3/16	0.188	0.188	0.197	0.177
7/16	0.4375	7/32	0.219	0.219	0.228	0.208
1/2	0.5000	1/4	0.250	0.250	0.260	0.240
5/8	0.6250	5/16	0.312	0.312	0.322	0.302
3/4	0.7500	3/8	0.375	0.375	0.385	0.365
7/8	0.8750	1/2	0.500	0.438	0.447	0.427
1	1.0000	9/16	0.562	0.500	0.510	0.490

NOTES FOR TABLE 21

1. THREADS. Threads are Class 3A UNC or UNF.

2. SOCKETS. See Page 13 Table 11, for hexagon socket dimensions.

TABLE 22 INTERNAL WRENCHING ALLENUTS

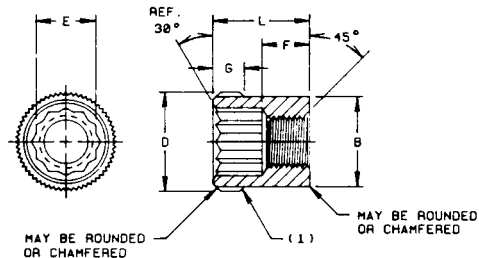

TABLE 22 DIMENSIONS

NOMINAL NUT SIZE	B		L		D		E	F	G	MINIMUM COUNTERBORE HOLE SIZE (1)
	BODY DIAMETER		LENGTH OVERALL		KNURL DIAMETER		SOCKET SIZE	THREAD LENGTH	KNURL LENGTH	
	MAX.	MIN.	MAX.	MIN.	MAX.	MIN.	NOM.	MIN.	MIN.	
4	0.187	0.183	0.179	0.172	0.209	0.205	1/8	0.080	0.046	0.202
5	0.187	0.183	0.205	0.198	0.209	0.205	1/8	0.095	0.056	0.202
6	0.257	0.253	0.230	0.223	0.278	0.274	5/32	0.100	0.071	0.270
8	0.280	0.275	0.273	0.266	0.307	0.302	3/16	0.125	0.084	0.298
10	0.307	0.302	0.319	0.309	0.336	0.331	3/16	0.170	0.096	0.327
1/4	0.403	0.398	0.419	0.409	0.430	0.425	1/4	0.225	0.136	0.421
5/16	0.498	0.493	0.522	0.512	0.526	0.521	5/16	0.285	0.165	0.516
3/8	0.590	0.585	0.621	0.606	0.620	0.615	3/8	0.325	0.195	0.610
7/16	0.710	0.705	0.733	0.718	0.743	0.738	7/16	0.360	0.235	0.733
1/2	0.800	0.795	0.836	0.821	0.841	0.836	1/2	0.445	0.265	0.831
5/8	0.986	0.980	1.010	0.995	1.040	1.034	5/8	0.500	0.325	1.028
3/4	1.158	1.152	1.185	1.170	1.215	1.209	3/4	0.600	0.385	1.203
7/8	1.361	1.355	1.358	1.343	1.430	1.424	7/8	0.700	0.445	1.418
1	1.533	1.527	1.532	1.517	1.620	1.612	1	0.810	0.495	1.606

NOTES FOR TABLE 22

1. Dimensions given indicate minimum counterbore hole size where Allenut is to be pressed or drawn into nonhardened material for anchoring purposes.

2. MATERIAL. (a) Alloy Steel hardened by quenching in oil and tempering to HRC 33-39. (b) Steel, corrosion resistant of type 203-EZ or equivalent.

3. THREADS. Threads shall be UNC-2B or UNF-2B series in accordance with ANSI B1.1 and FED-STD-H28.

4. MECHANICAL PROPERTIES. Product will meet the proof load requirements of ASTM A-194 Grade 2H Heavy hex nuts.

There are no reference specifications, as the Allenut represents an original, genuine Allen-designed product.

TABLE 23 HOLO-KROME THREAD STANDARDS

CLASS. Holo-Krome Socket Head Cap Screws through one inch in diameter and all other Holo-Krome standard threaded products are

manufactured to a Class 3A thread fit. Socket Head Cap Screws above one inch in diameter are made to Class 2A.

TABLE 23 UNIFIED SERIES CLASS 3A

NOMINAL SIZE	COARSE SERIES						FINE SERIES					
	THREADS PER INCH UNRC	PITCH DIAMETER		MAJOR DIAMETER		MINIMUM MINOR DIAM.	THREADS PER INCH UNRF	PITCH DIAMETER		MAJOR DIAMETER		MINIMUM MINOR DIAM.
		MAX.	MIN.	MAX.	MIN.			MAX.	MIN.	MAX.	MIN.	
0	-	-	-	-	-	-	80	0.0519	0.0506	0.0600	0.0568	0.0425
1	64	0.0629	0.0614	0.0730	0.0629	0.0513	72	0.0640	0.0626	0.0730	0.0695	0.0536
2	56	0.0744	0.0728	0.0860	0.0819	0.0612	64	0.0759	0.0744	0.0860	0.0822	0.0643
3	48	0.0855	0.0838	0.0990	0.0945	0.0703	56	0.0874	0.0858	0.0990	0.0949	0.0742
4	40	0.0958	0.0939	0.1120	0.1069	0.0777	48	0.0985	0.0967	0.1120	0.1075	0.0832
5	40	0.1088	0.1069	0.1250	0.1199	0.0906	44	0.1102	0.1083	0.1250	0.1202	0.0936
6	32	0.1177	0.1156	0.1380	0.1320	0.0953	40	0.1218	0.1198	0.1380	0.1329	0.1036
8	32	0.1437	0.1415	0.1640	0.1580	0.1212	36	0.1460	0.1439	0.1640	0.1585	0.1259
10	24	0.1629	0.1604	0.1900	0.1828	0.1334	32	0.1697	0.1674	0.1900	0.1840	0.1471
1/4	20	0.2175	0.2147	0.2500	0.2419	0.1823	28	0.2268	0.2243	0.2500	0.2435	0.2011
5/16	18	0.2764	0.2734	0.3125	0.3038	0.2374	24	0.2854	0.2827	0.3125	0.3053	0.2557
3/8	16	0.3344	0.3311	0.3750	0.3656	0.2906	24	0.3479	0.3450	0.3750	0.3678	0.3180
7/16	14	0.3911	0.3876	0.4375	0.4272	0.3413	20	0.4050	0.4019	0.4375	0.4294	0.3695
1/2	13	0.4500	0.4463	0.5000	0.4891	0.3964	20	0.4675	0.4643	0.5000	0.4919	0.4319
5/8	11	0.5660	0.5619	0.6250	0.6129	0.5029	18	0.5889	0.5854	0.6250	0.6163	0.5494
3/4	10	0.6850	0.6806	0.7500	0.7371	0.6157	16	0.7094	0.7056	0.7500	0.7406	0.6650
7/8	9	0.8028	0.7981	0.8750	0.8611	0.7260	14	0.8286	0.8245	0.8750	0.8647	0.7781
1	8	0.9188	0.9137	1.0000	0.9850	0.8325	12	0.9459	0.9415	1.0000	0.9886	0.8874

UNIFIED SERIES CLASS 2A

1-1/8	7	1.0300	1.0228	1.1228	1.1064	.9300	12	1.0691	1.0631	1.1232	1.1118	1.0090
1-1/4	7	1.1550	1.1476	1.2478	1.2314	1.0548	12	1.1941	1.1879	1.2482	1.2368	1.1338
1-3/8	6	1.2643	1.2563	1.3726	1.3544	1.1480	12	1.3190	1.3127	1.3127	1.3617	1.2586
1-1/2	6	1.3893	1.3812	1.4976	1.4794	1.2729	12	1.4440	1.4376	1.4981	1.4867	1.3835
1-3/4	5	1.6174	1.6085	1.7473	1.7268	1.5092	-	-	-	-	-	-
2	4-1/2	1.8528	1.8433	1.9971	1.9751	1.6900	-	-	-	-	-	-

RADIUSED RUNOUT THREADS. To ensure maximum resistance to fatigue, the incomplete or runout threads on all Holo-Krome standard threaded products where applicable are radiused.

RADIUS ROOT. All Holo-Krome standard socket head cap screws, flat head cap screws, button head cap screws, low head cap screws, and shoulder screws are manufactured to UNR form controlled root radius threads for increased fatigue strength. The opposite table illustrates the radius root limits for the UNR form threads:

Applicable Standards and Specifications
ANSI B1.1 and B1.3

RADIUS ROOT DIMENSIONS

PITCH (TPI)	RADIUS		PITCH (TPI)	RADIUS	
	MIN.	MAX.		MIN.	MAX.
80	0.0014	0.0018	16	0.0068	0.0090
72	0.0015	0.0020	14	0.0077	0.0103
64	0.0017	0.0023	13	0.0083	0.0111
56	0.0019	0.0026	12	0.0090	0.0120
48	0.0023	0.0030	11	0.0098	0.0131
44	0.0025	0.0033	10	0.0108	0.0144
40	0.0027	0.0036	9	0.0120	0.0160
36	0.0030	0.0040	8	0.0135	0.0180
32	0.0034	0.0045	7	0.0155	0.0206
28	0.0039	0.0052	6	0.0180	0.0241
24	0.0045	0.0060	5	0.0217	0.0289
20	0.0054	0.0072	4-1/2	0.0241	0.0321
18	0.0060	0.0080			

TABLE 24 HOLO-KROME FINISHES

FINISH SPECIFICATIONS	COATINGS OR SURFACE TREATMENTS
Thermal Black Oxide	— Standard heat treatment finish, includes light drying oil
Chemical Black Oxide	— Chemical treatment plus rust resistant, non-drying oil
Mil-C-13924	— Same as chemical black oxide except for type of oil used
Air Tempered	— Plain, heat treated finish with no oil, suitable for plating
Passivated	— Final treatment for stainless steel, QQ-P-35
Phosphate	— Zinc phosphate per MIL-P-16232 Type Z Class 3
Phosphate & Oil	— Zinc phosphate plus non-drying oil per MIL-P-16232 Type Z Class 2
Phosphate & Oil	— Zinc Phosphate plus drying oil per MIL-P-16232 Type Z Class 1
Zinc Plated	— Electroplated Zinc per ASTM B 633 Also QQ-Z-325
Cadmium Plated	— Electrodeposited Cadmium per ASTM B766 Also QQ-P-416
Endurion	— Tin-Zinc Phosphate with drying oil and colored dye as specified.
Electroless Nickel	— Nickel plating for wear resistance.

TABLE 24A

GALVANIC CORROSION

Galvanic corrosion occurs when two dissimilar metals are in contact, in a liquid capable of carrying electric current. Under these conditions the least noble metal (the anode) corrodes, while the more noble metal (the cathode) is not attacked.

In general, galvanic corrosion may be avoided by uniformity in types of metals used. If uniformity is not practical, metals should be used which are as close as possible to each other in the galvanic table below which lists metals in order of increasing nobility.

Stainless steel is "active" when chemicals present do not allow the formation of an oxide film on the surface of the metal. The treatment of stainless in a passivating solution will accelerate the formation of the oxide film, thus making it "passive" and thereby increasing its resistance to galvanic corrosion.

When dissimilar metals are used together, separate them with a dielectric material or coating.

GALVANIC SERIES (IN SEA WATER)

+ Corroded End (anodic, or least noble)

Magnesium	}	Type 410
Magnesium Alloys		
Zinc		
Aluminum		
Cadmium		
Iron and Carbon Steel		
4-6% Cr. Steel (active)		
Stainless (active)		
Lead-Tin Solder		
Lead		
Tin	}	Type 430
Nickel (active)		
Inconel (active)		
Brasses		
Copper		
Bronzes		
Copper-nickel Alloys		
Monel		
Silver Solder		
Nickel (passive)		
Inconel (passive)	}	Type 302
Stainless (passive)		
Silver		
Graphite		
Gold		
Platinum		
	}	Type 310
	}	Type 316

- Protected End (cathodic, or most noble)

TABLE 24B

EXPANSION OF METALS DUE TO TEMPERATURE

$$L_1 = (L_0) (T_2 - T_1) (c)$$

L_1	=	Increase in length in inches.
L_0	=	Original length, expressed in inches.
T_2	=	the higher temperature, in °F.
T_1	=	the lower temperature, in °F.
c	=	Coefficient of Thermal Expansion, expressed in inches per inch per Degree Fahrenheit.

**MECHANICAL PROPERTIES
AND
APPLICATION DATA
INCH PRODUCT**

MECHANICAL PROPERTIES AND APPLICATION DATA

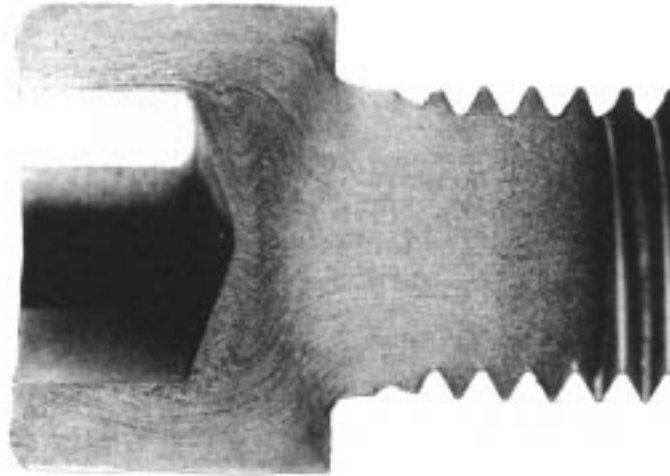

MECHANICAL REQUIREMENTS

SPECIFICATIONS

Holo-Krome socket products are manufactured in accordance with and tested to meet the requirements of various specifications. In the dimensional data pages of this handbook, two specifications are generally listed. There is an ASME/ANSI B18 document identified for nearly every product, which delineates the dimensional characteristics of the product. In addition, there is an ASTM Specification also identified for each product, from which the mechanical properties and testing requirements given herein are derived.

MATERIALS

Holo-Krome Alloy Steel Socket Products are made from a material which consists of a carbon steel to which one or more of the following elements has been added to provide heat treatment response to insure that the specified properties are met after the appropriate heat treatment. The alloying elements may be: chromium, nickel, molybdenum or vanadium only. There are various materials used to obtain the necessary properties, but all of them meet the chemical requirements of the specifications, and all are alloy steels.

HEAT TREATMENT PRACTICE

Holo-Krome Alloy Steel Socket Products are hardened and tempered in atmospherically controlled furnaces to meet the requirement of a neutral, through-hardened structure, consisting of tempered martensite. Required minimum tempering temperatures are adhered to, and the products meet all of the chemical and physical requirements of the specifications. The atmosphere is controlled to prevent carburization or decarburization as required by the specifications.

HEADING PRACTICE

Screws from #0 through 1 inch diameter (and the Metric counterparts) are normally Thermo-Forged® to insure proper grain flow and reduced internal stresses. Sizes over 1 inch diameter are hot formed.

THREADING PRACTICE

Standard Holo-Krome Alloy Steel Socket Head Cap Screws through 1-3/4" in diameter are roll threaded, while thread lengths longer than standard or special thread pitches may be rolled or cut. Set Screw threads may be rolled, cut or ground.

APPLICATION DATA

Standard Holo-Krome Alloy Steel Socket Products are manufactured to provide the optimum performance characteristics. The hardness is carefully controlled, not only to be within specification, but also to provide a part which will perform under difficult conditions. Ductility is maximized, to allow both the best possible fatigue life, and the ability to withstand the highest torquing loads to provide maximum clamping force and preload.

The Thermo-Forging process provides excellent grain-flow through the part, and, when complemented with the thread rolling process including radiused root run-out threads, provides optimum fatigue life.

For applications requiring high temperature resistance, corrosion resistance and many other special characteristics, special materials can be formed with the same process to provide the same benefits. Requests for special parts should be directed to the Holo-Krome Sales Department, and any technical questions or requests for information should be directed to the Holo-Krome Engineering Department.

WHY USE A SOCKET SCREW, INSTEAD OF LOW COST GRADE 2 OR GRADE 5 HEX HEAD?

On the surface, it may appear as though it is less expensive to purchase Grade 2 cap screws, than socket screws. Normally, when purchasing cap screws, you are buying holding power. The lowest cost fastener per pound of holding power is a socket screw. The graph below is based on relative cost data that should remain proportional regardless of the actual fastener cost. It can be seen that the socket screw has the lowest cost per pound of holding power.

Because a socket screw can hold more pounds per size, either fewer socket screws can be used or smaller size screws can be used. In either case, the cost of drilling and tapping is greatly reduced and the assembly size itself can be kept to a minimum. The actual total assembly cost is significantly lower.

It is also true that the manufacturing quality of a socket screw is far superior to a low-grade hex head. Socket screws have closer tolerance for better fit and radius root threads for greater reliability under dynamic loading.

Take, for example, a situation where 60,000 lbs. is the design load. This would require (4) 7/8 diameter Grade 2 hex heads, or (15) 3/8 diameter Grade 2 hex heads or (4) 3/8 diameter socket screws. Obviously, the structure would have to be much larger to accept the 7/8 diameter tapped holes. The cost of the larger drill and tap is approximately 7 times as much and the power to tap the hole is significantly higher. The socket screws provide the lowest cost, most reliable assembly.

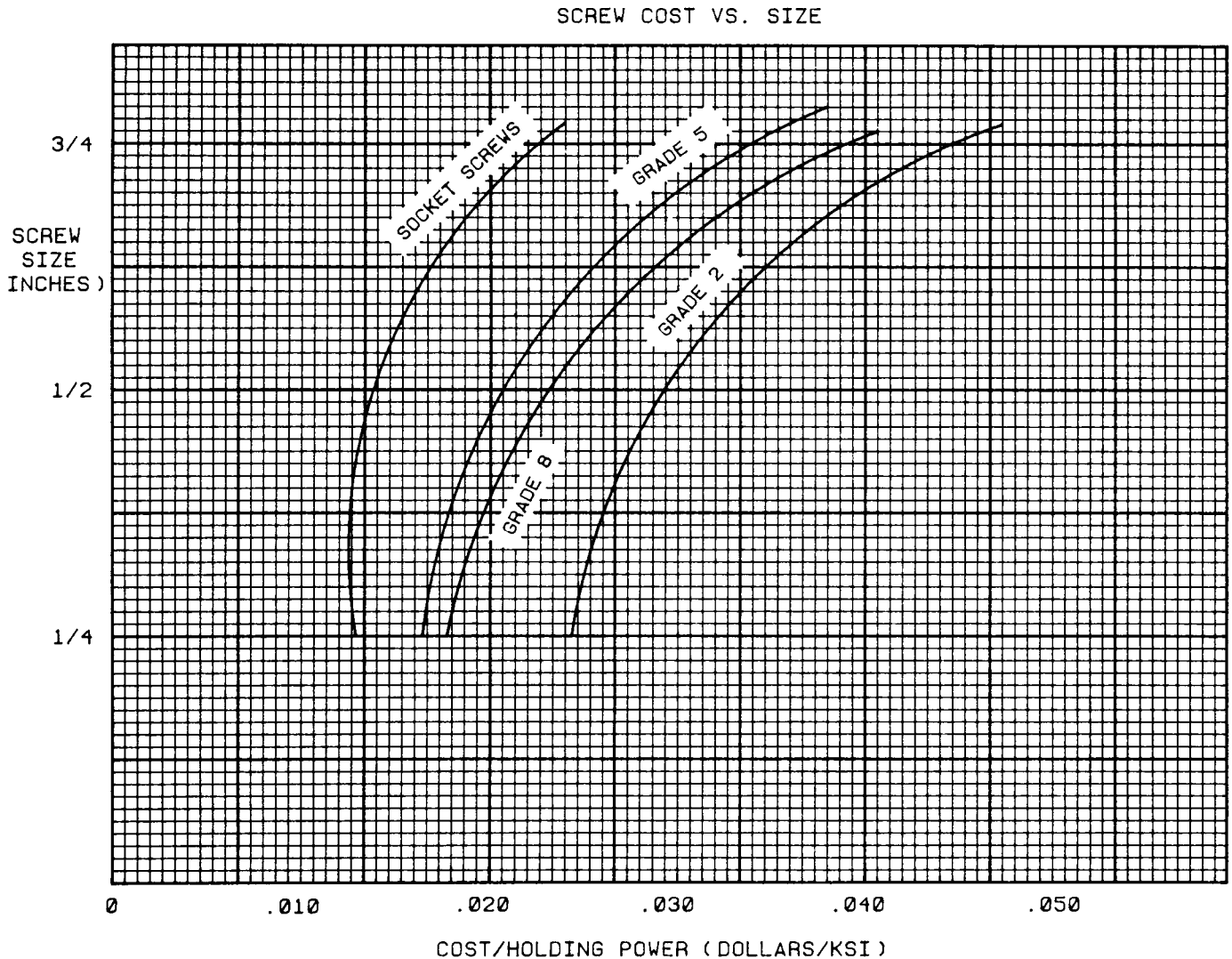

APPLICATIONS OF VARIOUS HEAD STYLES

SOCKET HEAD CAP SCREW

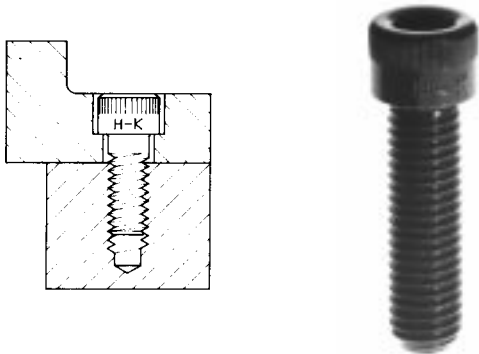

This screw is designed as a high tensile strength fastener for clamping assemblies against relative movement, parallel to the screw axis. Although its high strength allows machine components to be clamped with enough force to create a high resistance to lateral movement, this type of fastener is not meant to resist shear loads. In applications where high shear loading is possible, the assembly should be dowel pinned.

SOCKET BUTTON HEAD

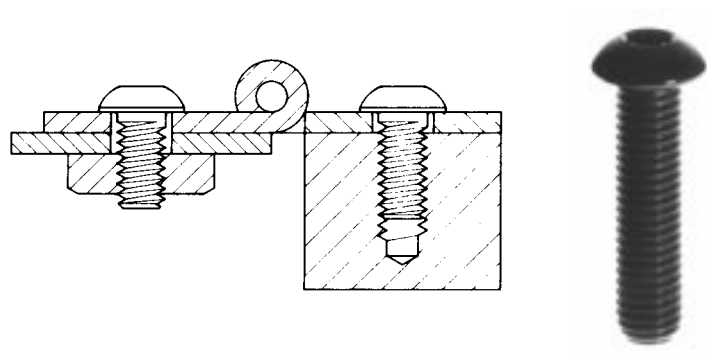

Button head screws are designed for light duty applications such as securing guards, covers, ornamental fixtures, etc. Button head screws present a pleasing appearance to an assembly. Holo-Krome can provide these screws with a tamper resistant socket.

SOCKET LOW HEAD

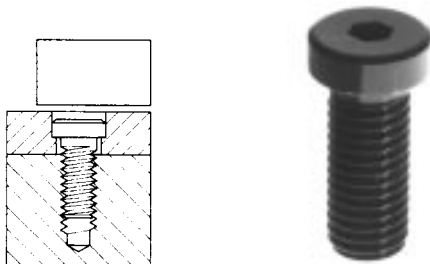

These are high strength, precision fasteners that are designed to be used in applications where head height clearance is a problem. Because of their reduced head height and smaller socket size, they normally cannot be preloaded as high as a standard socket head cap screw and should not be subjected to high dynamic loads.

SOCKET FLAT HEAD

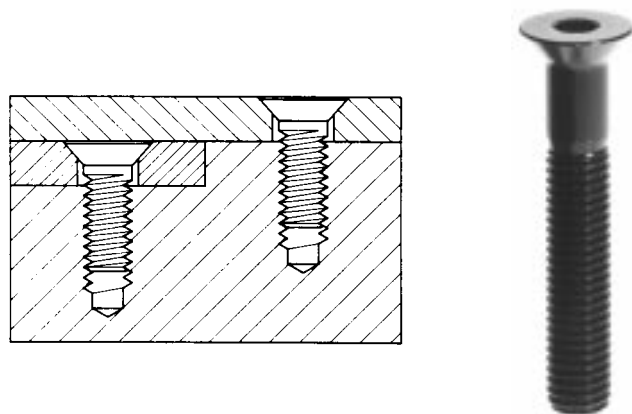

Flat head screws are used for flush mounting of sections, usually where one part slides over another or one part is mounted on another. Flat head screws, like button heads and low heads, are limited by configuration in their tensile strength capability. Because of this, they should not be used in applications requiring full strength, where Socket Head Cap Screws should be used.

TABLE 25 HOLO-KROME MECHANICAL PROPERTIES SOCKET HEAD CAP SCREWS—1960 SERIES



Standard Holo-Krome Alloy Steel Socket Head Cap Screws are manufactured from Holo-Krome analysis high grade alloy steel hardened and tempered to provide the following mechanical properties:

NOMINAL SIZES	TENSILE STRENGTH psi MIN.	YIELD STRENGTH psi MIN.	ELONGATION* IN 2 INCHES PER CENT MIN.	REDUCTION OF AREA* PER CENT MIN.	MINIMUM HARDNESS ROCKWELL C
0 to 1/2	180,000	162,000	8	35	39
Over 1/2	170,000	153,000	10	40	37

* The values for elongation and reduction of area apply only to cylindrical test specimens.
Values are based on ASTM A-574

CAUTION: IMPROPER LOADING OF THESE FASTENERS WILL CAUSE FAILURES

TABLE 25 TENSILE, YIELD AND SHEAR STRENGTH

NOMINAL SIZE	BASIC SCREW DIAMETER	THREAD STRESS AREA		STRAIGHT TENSILE STRENGTH (POUNDS MIN.)		STRAIGHT YIELD STRENGTH (POUNDS MIN.)		SINGLE SHEAR STRENGTH (POUNDS MIN.)		
		UNRC	UNRF	UNRC	UNRF	UNRC	UNRF	BODY SECTION	THREAD SECTION	
									UNRC	UNRF
0	0.0600	—	0.00180	—	320	—	290	305	—	205
1	0.0730	0.00263	0.00278	475	500	425	450	450	290	315
2	0.0860	0.00370	0.00394	665	710	600	635	625	405	445
3	0.0990	0.00487	0.00523	875	940	790	845	830	535	595
4	0.1120	0.00604	0.00661	1,090	1,190	975	1,070	1,060	665	750
5	0.1250	0.00796	0.00830	1,430	1,490	1,290	1,345	1,325	875	940
6	0.1380	0.00909	0.01015	1,640	1,825	1,470	1,645	1,615	1,000	1,150
8	0.1640	0.0140	0.01474	2,520	2,650	2,270	2,385	2,280	1,535	1,670
10	0.1900	0.0175	0.0200	3,150	3,600	2,835	3,240	3,060	1,920	2,270
1/4	0.2500	0.0318	0.0364	5,725	6,550	5,150	5,900	5,295	3,495	4,130
5/16	0.3125	0.0524	0.0580	9,430	10,440	8,490	9,395	8,285	5,750	6,575
3/8	0.3750	0.0775	0.0878	13,950	15,805	12,555	14,225	11,910	8,510	9,950
7/16	0.4375	0.1063	0.1187	19,135	21,365	17,220	19,230	16,200	11,650	13,445
1/2	0.5000	0.1419	0.1599	25,540	28,780	22,990	25,905	21,175	15,565	18,105
5/8	0.6250	0.226	0.256	38,400	43,500	34,550	39,150	31,300	23,450	27,400
3/4	0.7500	0.334	0.373	56,750	63,400	51,100	57,050	45,050	34,650	39,950
7/8	0.8750	0.462	0.509	78,500	86,500	70,700	77,850	61,350	47,900	54,500
1	1.0000	0.606	0.663	103,000	112,700	92,700	101,450	80,100	62,850	71,000
1-1/4	1.2500	0.969	1.073	164,700	182,400	148,250	164,150	125,100	100,500	114,900
1-1/2	1.5000	1.405	1.581	238,800	268,800	214,950	241,900	180,200	145,700	169,300

NOTES FOR TABLE 25

The mechanical properties listed are for standard screws tested at normal room temperatures. In applications where the temperatures are considerably above or below room temperature the effect of the temperature on the screw strength must be considered. Short time tensile, creep and stress relaxation should be considered for applications where the temperature exceeds 400°F (204°C). Lower ductility, impact strength and fatigue life must be considered for screws subject to temperatures below -20°F (-29°C).

The materials and heat treatment used for standard Holo-Krome Alloy Socket Head Cap Screws were selected to provide products that would have optimum tensile strength, impact strength and fatigue life. For specific applications, screws can be supplied to higher hardness levels so that their tensile strength will exceed values listed. However, such screws will have lower ductility, impact strength and fatigue life at higher stress levels than will standard screws.

TABLE 26 HOLO-KROME SOCKET HEAD CAP SCREWS - TORQUE DATA - 1960 SERIES

TORQUE-TENSION		TIGHTENING TORQUE DATA			
NOMINAL SIZE	BASIC SCREW DIAMETER	TENSION INDUCED IN SCREWS TORQUED AS RECOMMENDED (POUNDS)		RECOMMENDED TIGHTENING TORQUE (INCH - POUNDS)*	
		UNRC	UNRF	UNRC	UNRF
0	0.0600	—	190	—	2.6
1	0.0730	280	290	4.5	4.8
2	0.0860	390	410	7.5	8.0
3	0.0990	510	550	11.0	12.0
4	0.1120	630	690	16.0	18.0
5	0.1250	830	870	24.0	24.0
6	0.1380	950	1,070	30.0	34.0
8	0.1640	1,460	1,550	55.0	58.0
10	0.1900	1,840	2,100	79.0	90.0
1/4	0.2500	3,530	4,040	200.0	230.0
5/16	0.3125	5,820	6,450	415.0	460.0
3/8	0.3750	8,620	9,770	740.0	845.0
7/16	0.4375	11,830	13,180	1,190.0	1,305.0
1/2	0.5000	15,760	17,800	1,800.0	2,065.0
5/8	0.6250	23,740	26,890	3,400.0	3,800.0
3/4	0.7500	35,080	39,150	6,000.0	6,750.0
7/8	0.8750	41,590	45,830	8,250.0	9,200.0
1	1.0000	54,350	59,662	12,500.0	13,000.0
1-1/4	1.2500	87,225	96,600	25,000.0	27,750.0
1-1/2	1.5000	126,450	142,280	43,500.0	49,000.0

* These tightening torque values are 75% of the torque required to yield the screw, and apply only for the conditions listed below. Different percentages of torque-to-yield values are also commonly used for special conditions.

NOTES FOR TABLE 26

These are average values for standard Holo-Krome 1960 Series Alloy Steel Socket Cap Screws with black finish, tested with hardened steel plates, and hardened nuts with the threads and bearing areas lubricated with plain, medium viscosity machine oil.

The relationship between the torque and the induced tension (preload) can be expressed by the empirical formula $T=KDP$, in which T is the tightening torque in inch pounds; D is the nominal diameter of the screw; P is the tension (in pounds) induced in the screw; and K is the torque coefficient. The torque coefficient is not constant but varies with the material, surface finish and lubricity of the threads and head bearing area of the screws and parts fastened.

For the conditions shown above (standard alloy steel black finished screws clamping hardened steel parts), K will range from 0.19 to 0.25. For cadmium plated screws with steel parts, K will usually fall between 0.13 and 0.17. For zinc plated screws K may fall between 0.30 and 0.34. When the thread and head bearing surfaces are covered with certain types of lubricants, or with anti-seize compounds, K can drop as low as 0.05. At the other extreme, combinations of certain materials, such as austenitic stainless steel screws and parts not lubricated or coated, can result in K values as high as 0.35, or more.

Because the induced tension can vary considerably from one type of assembly to another for any given torque, the above data should be used with caution — particularly in applications where the control of preload is critical and must be obtained by the torque wrench method. For such applications, the relationship between torque and induced

tension should be determined experimentally for the actual parts and lubrication practice involved.

TIGHTENING TORQUES. At the tightening torques listed standard Holo-Krome alloy steel 1960 Series screws, used under the conditions described, will be preloaded to approximately 75% of the tension induced at yield. The bearing stress under the head at these preloads will be approximately 80,000 psi, so indentation should not occur when the parts clamped are of steel or cast iron with a hardness equal to or in excess of Rockwell B 85. With softer materials, washers may be required under the heads of the screws to avoid indentation.

In applications where screws are subject to fatigue from dynamic loading, the importance of proper preloading during assembly cannot be over-emphasized. The proper preload is especially important for rigid-type (metal-to-metal) joints, where it has been found that the use of a preload greater than the external load will usually eliminate the possibility of fatigue failure. For this reason, the preferred practice for such assemblies is to preload to 75% of the induced tension at yield.

FOR FLEXIBLE TYPE JOINTS, HOWEVER, AND FOR ASSEMBLIES EXPOSED TO ELEVATED TEMPERATURES, MUCH LOWER PRELOADS MAY BE REQUIRED. No general recommendations are possible for such assemblies or service conditions. Each application must be analyzed individually, because the preload requirements may vary considerably from one application to another. Users who desire suggestions for the preload or tightening torque to be used for a specific application are invited to contact Holo-Krome.

TABLE 27 DECARBURIZATION AND DISCONTINUITY LIMITS

CARBURIZATION OR DECARBURIZATION

Surface carbon content variations conform to the limits specified in Table 27 when tested in accordance with ASTM A 574. There should be no *complete* decarburization nor any carburization. Carburization or decarburization can only be measured accurately on a screw that has been cross sectioned on a plane that is parallel to and passes through the screw axis.

When the engineering requirements of the application require that decarburization must be more closely controlled, the purchaser should specify the applicable limits in the original inquiry and in the purchase order.

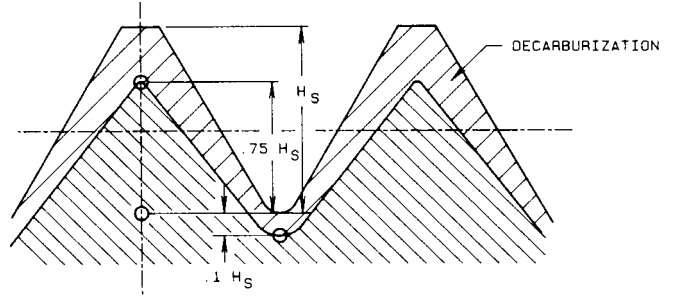

DISCONTINUITIES

SOCKET DISCONTINUITIES

Discontinuities in the socket area are allowed to a maximum depth of $0.03D$ or 0.005 inch (whichever is greater), providing they do not affect the usability and performance of the screw.

Longitudinal discontinuities must not exceed $0.25T$ in length. Permissible and nonpermissible discontinuities are shown in Figure 1.

PERMISSIBLE HEAD AND SHANK DISCONTINUITIES

Discontinuities as defined above are permitted in the locations illustrated in Figure 1 to the depths described above, with the addition that peripheral discontinuities are permitted a maximum depth = $0.06D$, but not over 0.064 inch. These discontinuities are permitted providing they do not affect the usability and performance of the screw. All discontinuities are measured perpendicular to the indicated surface.

When the engineering requirements of the application require that surface discontinuities must be more closely controlled, the purchaser should specify the applicable limits in the original inquiry and in the purchase order.

REJECTION

Rejections should be reported to Holo-Krome within 30 days of receipt of the parts, by the purchaser. The rejection may be in writing to the distributor or directly to the Holo-Krome Sales Department. When no special requirements are specified, industry standards such as ASTM A574 will be used as referee documents.

TABLE 27 DECARBURIZATION LIMITS

THREADS/IN.	THREAD HEIGHT, H	0.75 H FROM ROOT TO CREST, MIN.	0.1 H AT ROOT, MAX.
80	0.008	0.006	0.001
72	0.009	0.007	0.001
64	0.010	0.008	0.001
56	0.011	0.008	0.001
48	0.013	0.010	0.001
44	0.014	0.011	0.001
40	0.015	0.011	0.002
36	0.017	0.013	0.002
32	0.019	0.014	0.002
28	0.022	0.017	0.002
24	0.026	0.020	0.003
20	0.031	0.023	0.003
18	0.034	0.026	0.003
16	0.038	0.029	0.004
14	0.044	0.033	0.004
13	0.047	0.035	0.005
12	0.051	0.038	0.005
11	0.056	0.042	0.006
10	0.061	0.046	0.006
9	0.068	0.051	0.007
8	0.077	0.058	0.008
7	0.088	0.066	0.009
6	0.102	0.077	0.010
5	0.123	0.092	0.012
4.5	0.136	0.102	0.014
4	0.153	0.115	0.015

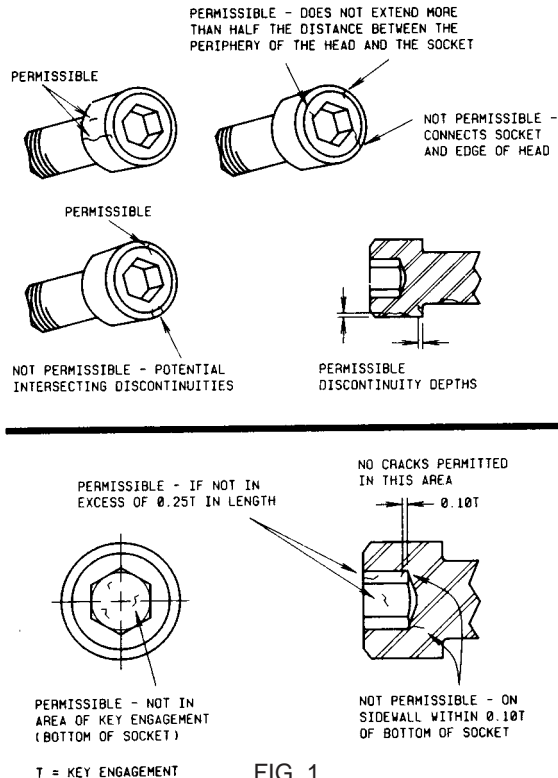
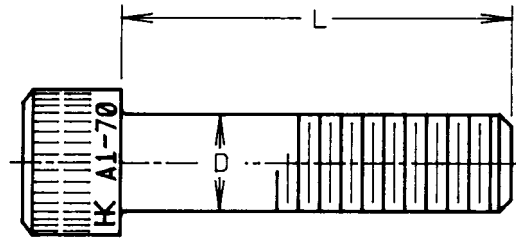

FIG. 1

TABLE 28 HOLO-KROME STAINLESS STEEL SOCKET HEAD CAP SCREWS



MATERIAL

Standard Holo-Krome Stainless Steel Socket Head cap screws are made from an austenitic (18-8) stainless steel. They withstand all ordinary rusting, are immune to all foodstuffs, sterilizing solutions, most of the inorganic chemicals, dyestuffs and a wide variety of organic chemicals. They resist nitric acid well, halogen acids poorly and sulfuric acids moderately.

Holo-Krome Stainless Steel cap screws are passivated by immersion

in a nitric acid bath subsequent to the last manufacturing operation. This rids the surface of contaminants picked up during fabrication that can cause surface staining or rusting.

Holo-Krome standard stainless steel cap screws have low magnetic permeability which makes them suitable for electrical applications where non-magnetic parts are required.

Applicable Standards and Specifications
ASTM F 837

TABLE 28 MECHANICAL PROPERTIES OF THREADED TO THE HEAD STAINLESS STEEL CAP SCREWS

NOMINAL SIZE	BASIC SCREW DIAMETER	TENSILE STRENGTH* (POUNDS MIN.)		YIELD STRENGTH** (POUNDS MIN.)		SINGLE SHEAR STRENGTH (POUNDS MIN.)		TIGHTENING TORQUE INCH - POUNDS	
						THREAD SECTION			
		UNRC	UNRF	UNRC	UNRF	UNRC	UNRF	UNRC	UNRF
0	.0600	-	171	-	54	-	103	-	1.4
1	.0730	250	265	79	83	150	159	2.5	2.6
2	.0860	350	375	111	117	211	225	4.0	4.5
4	.1120	575	630	181	198	344	377	6.0	9.0
6	.1380	865	965	273	305	518	579	16.0	18.0
8	.1640	1330	1400	420	442	798	840	30.0	34.0
10	.1900	1660	1900	525	600	998	1140	42.0	48.0
1/4	.2500	3020	3460	954	1092	1813	2075	100.0	116.0
5/16	.3125	4980	5510	1570	1740	2987	3306	184.0	203.0
3/8	.3750	7360	8340	2325	2635	4418	5000	329.0	371.0
1/2	.5000	13500	15200	4268	4800	8088	9115	805.0	910.0

* Apply only to stock sizes. All other lengths and sizes will have a minimum tensile strength of 80,000 psi.

** On specimens only

Values based on ASTM F837

NOTES FOR TABLE 28

Tensile strengths given above are for standard stainless steel socket head cap screws, 1960 Series tested at room temperatures. When screws are to be exposed to higher temperatures the effect of temperature upon the short time properties and the possibility of plastic deformation, or creep, should be considered. At 800°F., the tensile strength of standard stainless steel screws will be approximately 75% of the room temperature strength, and the screws have good creep

resistance. Normally, standard stainless steel screws are not used above 800°F., because above this temperature the material is subject to intergranular corrosion.

The mechanical properties and torquing data for cap screws made from stainless steels other than the standard material, or for sizes and lengths not stocked, will be furnished on request.

TABLE 29 HOLO-KROME BUTTON HEAD AND FLAT COUNTERSUNK HEAD SCREWS

CAUTION:

BUTTON HEAD CAP SCREWS ARE DESIGNED FOR LIGHT FASTENING APPLICATIONS ONLY, SUCH AS SHEETMETAL COVERS, PLASTIC GUARDS, ETC. THEY SHOULD NOT BE USED IN CRITICAL HIGH STRENGTH APPLICATIONS WHERE SOCKET HEAD CAP SCREWS SHOULD BE USED.

Standard Holo-Krome Alloy Steel Button, Flat and Low Head Cap Screws are manufactured from Holo-Krome analysis high grade alloy steel, hardened and tempered to provide the following mechanical properties. Because of the head configuration, neither button nor flat head socket cap screws can develop the full strength of the raw material heat treatment,

and the values show below for tensile values are minimum strengths which full size screws will pull in a tensile test.

Applicable Standards and Specifications
ASTM F835

TABLE 29 MECHANICAL PROPERTIES AND TIGHTENING TORQUES FOR BUTTON AND FLAT COUNTER-SUNK HEAD CAP SCREWS

NOMINAL SIZE	BASIC SCREW DIAMETER	BUTTON HEADS			FLAT COUNTERSUNK HEADS			
		TENSILE STRENGTH (POUNDS MIN.)	SHEAR STRENGTH (POUNDS MIN.)	TIGHTENING TORQUE (INCH - POUNDS)	TENSILE STRENGTH (POUNDS MIN.)	SHEAR STRENGTH (POUNDS MIN.)		TIGHTENING TORQUE (INCH - POUNDS)
						BODY SECTION	THREAD SECTION	
4	0.1120	880	620	8	880	1,100	620	9.5
5	0.1250	-	-	-	1,150	1,370	820	14
6	0.1380	1,320	940	15	1,320	1,670	940	18
8	0.1640	2,030	1,450	30	2,030	2,360	1,450	32
10	0.1900	2,540	1,810	65	2,540	3,180	1,810	75
1/4	0.2500	4,610	3,300	125	4,610	5,500	3,300	140
5/16	0.3125	7,600	5,430	200	7,600	8,590	5,430	245
3/8	0.3750	11,200	8,040	360	11,200	12,350	8,040	400
7/16	0.4375	-	-	-	15,400	16,800	11,000	600
1/2	0.5000	20,600	14,700	1000	20,600	22,000	14,700	1200
5/8	0.6250	30,500	23,400	1750	30,500	34,350	23,400	2000
3/4	0.7500	-	-	-	45,100	49,500	34,600	4000
7/8	0.8750	-	-	-	62,400	61,000	47,900	6000
1	1.0000	-	-	-	81,800	80,100	62,850	8500

The torque values given are for standard black screws in rigid joints, when torqued with standard keys or bits. Values based on ASTM F-835

NOTES FOR TABLE 29 AND TABLE 29A

The mechanical properties listed are for screws tested and used at normal room temperatures. The values for the Low Heads are based on a tensile strength of 170,000 psi minimum and a minimum hardness value of HRC38. In applications where the temperatures are considera-

ably below or above room temperature, the effect of the temperature must be considered. Short time tensile, creep and relaxation should be considered for applications where the temperature exceeds 400°F (204°C). Lower ductility, impact strength and fatigue life must be considered for screws subject to temperatures below -20°F (-29°C).

TABLE 29A MECHANICAL PROPERTIES AND TIGHTENING TORQUES FOR LOW HEAD SOCKET HEAD CAP SCREWS

NOMINAL SIZE	BASIC SCREW DIAMETER	LOW HEAD CAP SCREWS			
		TENSILE STRENGTH (POUNDS MIN.)	SHEAR STRENGTH (POUNDS MIN.)	TIGHTENING TORQUE (INCH - POUNDS)	HEX KEY SIZE
4	0.1120	840	620	5.0	0.050
5	0.1250	1,100	820	9.5	1/16
6	0.1380	1,260	940	9.5	1/16
8	0.1640	1,940	1,450	19.0	5/64
10	0.1900	2,440	1,810	30	3/32
1/4	0.2500	4,430	3,300	75	1/8
5/16	0.3125	7,300	5,430	150	5/32
3/8	0.3750	10,800	8,040	275	3/16
7/16	0.4375	14,800	11,000	425	7/32
1/2	0.5000	19,800	14,700	600	1/4
5/8	0.6250	31,500	23,400	1300	5/16

The torque values are based on the effective torque strength of a standard Allen Wrench used within its torque capabilities. Because of the size of the socket, these products may not be torqued to the full preload of which they are capable.

The torque values given are for standard black screws in rigid joints, when torqued with standard keys or bits.

TABLE 30 HOLO-KROME SOCKET SHOULDER SCREWS

SHOULDER SCREWS

Shoulder screws, commonly referred to as stripper bolts, are used in a variety of applications. In die sets, they can be used as guides for stripper springs. They are used as pivots for linkages, pulleys and sprockets and as hinges.

Holo-Krome socket shoulder screws are made from Holo-Krome analysis high grade alloy steel. Holo-Krome step grinds the shoulder and roll thread diameter in one operation after heat treatment to assure concentricity. The parts are then specially fed into the roll threader to virtually eliminate drunken threads and produce Class 3A UNRC threads.

MECHANICAL PROPERTIES

Tensile Strength 140,000 psi min
 Yield Strength 120,000 psi min
 Elongation in 2 inches* 15% min
 Reduction of Area* 45% min
 Hardness 32 Rockwell C min

*Apply to cylindrical test specimens only

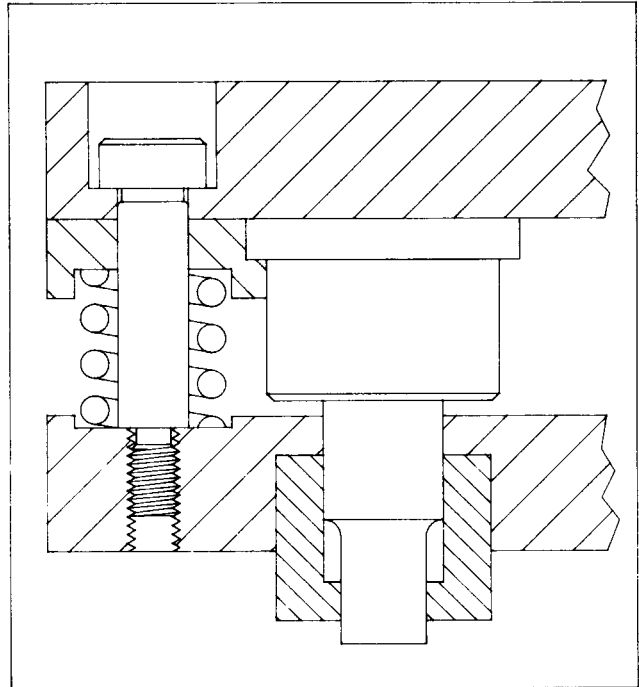

TABLE 30 MECHANICAL PROPERTIES

NOMINAL SHOULDER DIAMETER	NOMINAL THREAD SIZE	THREAD SECTION TENSILE STRENGTH (POUNDS MIN.)	SINGLE SHEAR STRENGTH (POUNDS MIN.)		HEX KEY SIZE	TIGHTENING TORQUE (INCH - POUNDS)**
			THREAD NECK	SHOULDER		
1/4	10 - 24	2,540	1,250	4,515	1/8	50
5/16	1/4 - 20	4,610	2,340	7,100	5/32	125
3/8	5/16 - 18	7,600	3,970	10,280	3/16	265
1/2	3/8 - 16	11,240	5,985	18,350	1/4	470
5/8	1/2 - 13	20,570	11,140	28,785	5/16	1,150
3/4	5/8 - 11	32,770	17,800	41,515	3/8	2,000
1	3/4 - 10	48,430	26,800	74,000	1/2	4,000

**It is recommended that tightening torque be limited to these values when screws are to be tightened or loosened with standard keys or bits.

HOLO-KROME SOCKET SET SCREWS — ALLOY STEEL — APPLICATION DATA

Holo-Krome is the only company that Thermo-Forges® socket set screws. This provides a deep socket with smooth walls and there are no broaching chips. It is a Holo-Krome test requirement that all standard, alloy steel set screws, of one diameter length or longer, break a properly hardened hex key when overtorqued, without damaging the socket.



CUP POINT. The cup point is the most commonly used point style. It is used for the fast permanent or semi-permanent assembly of parts such as collars, pulleys, gears or bearings on shafting of hardness up to within 10 to 15 Rockwell C points of the screw hardness and where the digging in of the point is not undesirable.



CONE POINT. The cone point set screw is used for permanent location of a machine part to a hardened or soft shaft. The point is frequently spotted particularly when used with a hardened shaft. The cone point is also used as a pivot or hanger point.



HOLO-KNURL® POINT. The knurled cup point set screw is designed for use in applications similar to the cup point but has added resistance to loosening under vibratory conditions. The forged counter clockwise knurl provides a ratchet type of self-locking action usable even with shafting of hardness up to within 10 to 15 Rockwell C points of the screw hardness. Holo-Knurl set screws as supplied with the Holo-Torc finish have higher holding power than any standard off-the-shelf set screw.



OVAL POINT. The oval point is used where frequent adjustments may be required or where excessive indentation of the shafting or mating part by the point is not desirable. It may be used in applications where the point contacts the shaft or mating part at an angle. The oval point is also used with a spot or a circular or longitudinal groove of similar contour as the oval point itself.



HALF DOG POINT. The half dog point is generally used for the permanent or fixed location of machine parts on parts such as hardened shafting, hollow tubing, or in place of dowels. When spotted, the hole should always be of the same diameter as the point. The non-standard full dog point is designed for similar applications or where a longer point is desired.

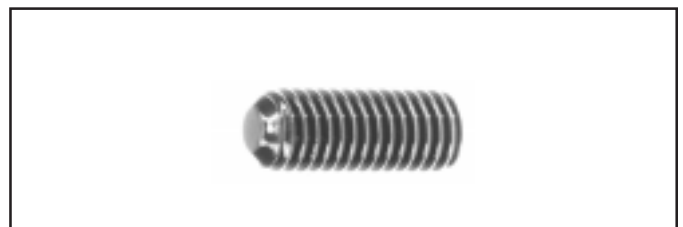

FLAT POINT. The flat point is used for frequent relocation of machine parts on shafting with the least amount of deformation to the shaft surface. The flat point is also useful as a backing for a brass or soft metal plug.

TABLE 31 HOLO-KROME SOCKET SET SCREWS — AXIAL HOLDING POWER

AXIAL HOLDING POWER OF CUP POINT AND HOLO-KNURL™ POINT SET SCREWS (ALLOY STEEL)

NOMINAL SIZE	BASIC SCREW DIAMETER	HEX KEY SIZE	TIGHTENING TORQUE (INCH — POUNDS)	AXIAL HOLDING POWER (POUNDS)	
				CUP POINT WITH BLACK FINISH	HOLO-KNURL™ WITH HOLO-TORC*
0	0.0600	0.028	1.1	50	74
1	0.0730	0.035	2.1	63	93
2	0.0860	0.035	2.1	80	115
3	0.0990	0.050	6.0	110	165
4	0.1120	0.050	6.0	140	210
5	0.1250	1/16	11	180	265
6	0.1380	1/16	11	200	295
8	0.1640	5/64	23	365	540
10	0.1900	3/32	40	550	810
1/4	0.2500	1/8	94	1,000	1,470
5/16	0.3125	5/32	183	1,600	2,350
3/8	0.3750	3/16	317	2,200	3,250
7/16	0.4375	7/32	502	3,000	4,400
1/2	0.5000	1/4	750	3,700	5,450
5/8	0.6250	5/16	1,460	5,600	8,250
3/4	0.7500	3/8	2,520	7,500	11,000
7/8	0.8750	1/2	5,750	10,500	15,500
1	1.0000	9/16	8,000	14,500	21,500

* The higher axial holding power is due to the excellent lubricity of the Holo-Torc™ finish, which is available on special order for Holo-Krome screws.

NOTE — The values above have been developed experimentally by assembling steel collars to cold finished steel bars (Rockwell B 80-100) with standard Holo-Krome alloy steel Cup Point Set Screws with the black finish and standard Holo-Knurl Point Set Screws with Holo-Torc Finish. The set screws were all as long or longer than their nominal diameter. The axial holding power listed above was the average force required to cause a 0.005 inch movement of the collar along the shaft after tightening the set screw to the listed torque. For specific applications, values may vary as much as ± 30 percent from values shown.

Giving a cup point a relative holding power of 1, the holding power of a cone point is 1.07, a flat point or dog point 0.92 and an oval point 0.9. For torsional holding power, multiply the axial holding power value by the shaft radius.

SET SCREW HOLDING POWER

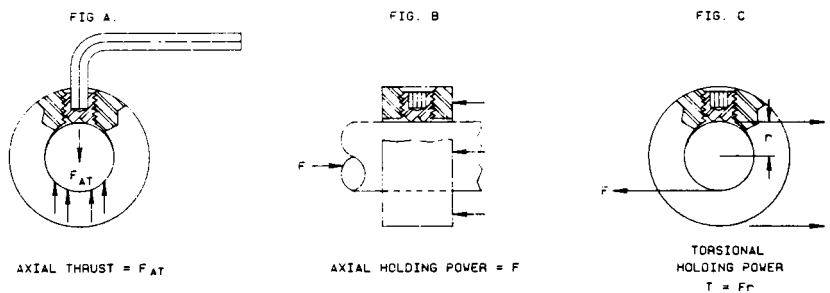

INTRODUCTION. Set screws @ HRC48-52, unlike most other fasteners, are basically compression fasteners. Because studies made of tension fasteners do not apply and because of the complex nature of this type of joint, the holding power of a set screw is more difficult to predict and control than the typical cap screw joint. Many variables introduced by a particular application may affect the holding power performance of a set screw. It is therefore important for the designer to understand set screw holding power and the nature of the variables involved when designing a set screw joint.

HOLDING POWER. The forces which a set screw assembled joint can transmit or withstand without relative displacement of the two parts is a measure of the holding power of the screw. This holding power can best be described in terms of the forces acting to cause relative movement

between the assembled parts.

1. AXIAL HOLDING POWER. Using a simple shaft collar application as an illustration, the force acting on the collar to move it along the shaft is called the axial force. The ability of the set screw to withstand this force without relative displacement is called its Axial Holding Power. (See Figure B.)

2. TORSIONAL HOLDING POWER. Using a shaft pulley or gear application as an example, the force (F) acting to rotate or slip the pulley around the shaft is frequently called the rotational force. The ability of a set screw to withstand these forces tending to rotate the part on the shaft without relative movement of the two parts is called Torsional Holding Power. (See Figure C.)

The torsional holding power of the set screw in the given application can then be determined from the following relationship:

$$T = Fr$$

Where (T) equals Torsional Holding Power in inch-pounds, (F) equals Axial Holding Power in pounds and (r) equals shaft radius in inches.

Example: To determine the torsional holding power of a 3/8 diameter Holo-Krome Cup Point Set Screw assembled on a 5/8 inch diameter shaft, multiply 2200 pounds (the average axial holding power from Table 31) by 5/16 inch. $2200 \times 5/16 = 688$ inch-pounds Torsional Holding Power.

3. VIBRATIONAL HOLDING POWER. Vibrational Holding Power may be defined as the resistance of a set screw to loosening under vibration or dynamic loading. Holo-Krome has determined, as a result of numerous studies, that a set screw will not fail or loosen if the peak forces acting on it, whether vibration induced or from external dynamic loads, do not exceed the ultimate axial or torsional holding power values. For the screw to loosen, the compressive stress existing between the point and the first engaged thread must be relieved as a result of deformation of the shafting material adjacent to the set screw point or the threads of the collar. This compressive stress creates friction in the mating threads and between the point and shaft which lock the set screw. The internally knurled Holo-Knurled® point significantly increases the locking action by trapping upset shaft material between the forged teeth. The helix angles of the standard thread series are so low that back-off forces created on the set screw itself by dynamic loading are insignificant compared to the frictional forces resisting loosening.

Unfortunately, in most cases the actual peak service forces acting upon the set screw are difficult to determine. If these peak forces are not known, some safety factor to provide a sufficient margin of holding power should be used. In most cases of failure due to vibrational loading investigated by Holo-Krome, the loosening has been caused by insufficient seating torque.

VARIABLES AFFECTING SET SCREW HOLDING POWER. When comparing the performance of various set screws or in the design of critical set screw assemblies, it is desirable to control as many of the variables affecting holding power as possible and to evaluate the effects of those not controlled. Research has disclosed that the following factors influence set screw holding power to varying degrees.

TIGHTENING OR SEATING TORQUE. Directly affects the axial thrust of the screw and therefore the ultimate holding power. The importance of using proper tightening torque cannot be overstressed. Because Holo-Krome sockets are Thermo-Forged,® they can be torqued to the key strength without cracking the socket wall.

POINT CONFIGURATION. Such factors as poorly machined set screw points and lack of thread-to-point concentricity can seriously affect holding power. Because Holo-Krome Thermo-Forged set screws have points and sockets forged simultaneously with the thread axis, concentricity is assured.

THREAD SURFACE LUBRICITY. This important factor is often overlooked in set screw studies. Lack of thread lubricity means increased thread friction which consumes driving torque. A high degree of surface lubricity efficiently utilizes driving torque for optimum axial thrust and holding power. The Holo-Torc finish, which is available on special orders, provides excellent thread lubricity for unmatched holding power plus corrosion resistance equal to plating.

TAPPED HOLE THREAD SURFACE. The same reasons given above for set screw threads also hold true for tapped hole threads.

MATING PART SURFACE FINISH. The surface finish of the mating parts, for example a shaft and collar, is an important consideration. Because friction here is a desirable contributor to holding power these surfaces should have as low a degree of lubricity as possible.

THREAD HELIX ANGLE – NC OR NF. The UNF series set screws, because of their lower helix angle, do provide slightly higher holding power.

ALIGNMENT OF TAPPED HOLE WITH SHAFT. Any deviation between the axis of the set screw and the axis of the shaft decreases the amount of axial thrust that the screw can develop against the shaft and therefore reduces holding power.

OTHERS. Several other influencing factors may become important in certain applications and are worth attention. These are length of thread engagement, yield strength and thickness of collar or ring material, fit between shaft and collar, bearing yield strength of shaft material and nature of expected service loads.

MULTIPLE SET SCREWS

When using more than one set screw the effect of the additional screw depends on the relative angle between the screws. To determine the approximate holding power the following equation can be used:

$$P = \frac{H(200 - .42\theta)}{100}$$

Where:

P = Holding Power of assembly, lbs.

H = Holding Power of one set screw, lbs.

θ = Least angle between screws (180° or less), deg.

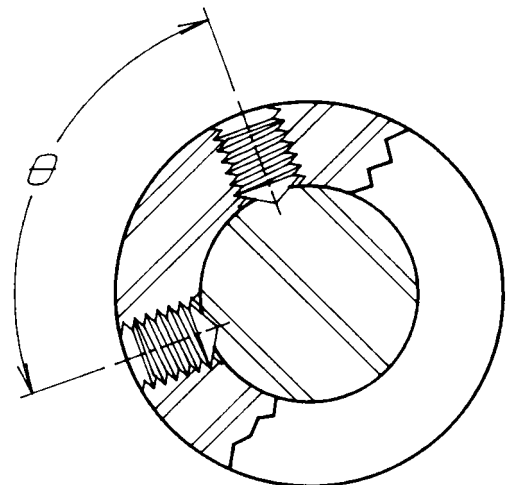
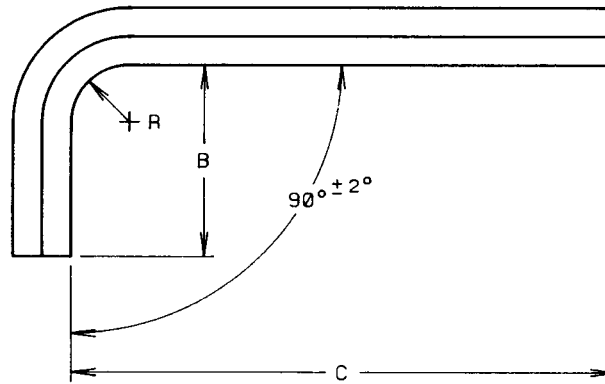

TABLE 32 ALLEN WRENCHES AND BITS



MECHANICAL PROPERTIES

Standard Allen Wrenches and Bits are manufactured from Holo-Krome Alloy Steel, hardened by quenching in oil from the hardening temperature

and tempered to a minimum hardness of HRC 45 at the surface to provide the following torsional properties:

TABLE 32 MECHANICAL PROPERTIES

NOMINAL KEY OR BIT SIZE	TORSIONAL SHEAR AVERAGE (INCH-POUNDS)	TORQUE RATING (INCH-POUNDS)
0.028	1.1	0.9
0.035	2.3	1.8
0.050	6.5	5.3
1/16	11.9	10.3
5/64	25.0	20.0
3/32	43.0	35.0
7/64	68.0	55.0
1/8	98.0	82.0
9/64	146.0	118.0
5/32	195.0	160.0
3/16	342.0	278.0
7/32	535.0	440.0
1/4	770.0	655.0
5/16	1,600.0	1,275.0
3/8	2,500.0	2,200.0
7/16	4,500.0	3,500.0
1/2	6,300.0	5,200.0
9/16	8,750.0	6,500.0
5/8	12,000.0	9,000.0
3/4	19,500.0	15,500.0
7/8	29,000.0	24,600.0
1	43,500.0	28,800.0

ALLEN WRENCHES APPLICATION DATA

NOMINAL KEY OR BIT SIZE	CAP SCREWS 1960 SERIES	FLAT COUNTERSUNK HEAD CAP SCREWS	BUTTON HEAD CAP SCREWS	SHOULDER SCREWS	SET SCREWS	PRESSURE PLUGS
	NOMINAL SCREW SIZES					
0.028	—	—	—	—	0	—
0.035	—	0	0	—	1 & 2	—
0.050	0	1 & 2	1 & 2	—	3 & 4	—
1/16 0.062	1	3 & 4	3 & 4	—	5 & 6	—
5/64 0.078	2 & 3	5 & 6	5 & 6	—	8	—
3/32 0.094	4 & 5	8	8	—	10	—
7/64 0.109	6	—	—	—	—	—
1/8 0.125	—	10	10	1/4	1/4	—
9/64 0.141	8	—	—	—	—	—
5/32 0.156	10	1/4	1/4	5/16	5/16	1/16
3/16 0.188	1/4	5/16	5/16	3/8	3/8	1/8
7/32 0.219	—	3/8	3/8	—	7/16	—
1/4 0.250	5/16	7/16	—	1/2	1/2	1/4
5/16 0.312	3/8	1/2	1/2	5/8	5/8	3/8
3/8 0.375	7/16 & 1/2	5/8	5/8	3/4	3/4	1/2
7/16 0.438	—	—	—	—	—	—
1/2 0.500	5/8	3/4	—	1	7/8	—
9/16 0.562	—	7/8	—	—	1 & 1-1/8	3/4
5/8 0.625	3/4	1	—	1-1/4	1-1/4 & 1-3/8	1
3/4 0.750	7/8 & 1	1-1/8	—	—	1-1/2	1-1/4
7/8 0.875	1-1/8 & 1-1/4	1-1/4 & 1-3/8	—	1-1/2	—	—
1 1.000	1-3/8 & 1-1/2	1-1/2	—	1-3/4	1-3/4 & 2	1-1/2, 2

NOTES FOR TABLE 32

TORSIONAL SHEAR STRENGTH. The average torsional shear strength tabulated above is the average maximum torque which standard keys and bits will transmit when tested to destruction. When so tested, failure should occur by a clean, square shear fracture.

TORQUE RATING. Standard Allen Wrenches cut into bits for use in torque wrenches will transmit the above torques.

These torque values are the average torque required to develop a permanent visible twist of not more than 10° in bits which have one inch of hexagon exposed between the torque wrench and the socket. These are also the torque values which keys transmit when the short arm is inserted in a socket and the long arm is deflected or bent through an angle of 25 to 30° by the application of force near the end of the long arm. These are the torque ratings from Federal Specification GGG-K-275D, Amend. 1.

TABLE 33 HOLO-KROME PRESSURE PLUGS

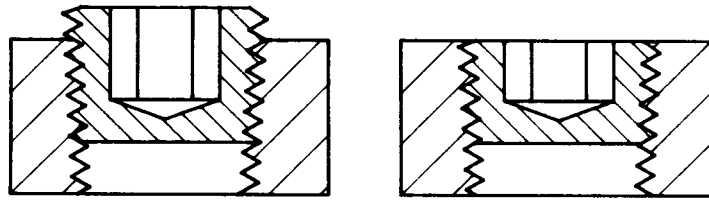

NPTF

PTF

PRESSURE PLUGS

Holo-Krome standard pressure plugs are made from high grade alloy steel, hardened and tempered to a through hardness of HRC 36-43. Since the plugs are Thermo-Forged® and roll threaded, they are inherently stronger and do not have broaching chips.

Two basic plug styles are standard with Holo-Krome. These are the 3/4 taper, designated NPTF, and the 7/8 taper, designated PTF. Both types have dry seal threads and both should be used in NPTF, 3/4 taper tapped holes.

The 3/4 taper plug is a longer plug and is the one most commonly used. It will work in tapped holes that are not accurately tapped.

The 7/8 taper plug has more closely controlled threads and is designed to be flush with the top of the tapped hole. The thread tolerances are closer than on the 3/4 taper plugs.

TABLE 33 APPLICATION DATA

NOMINAL SIZE	THREADS PER INCH	HEX KEY SIZE	TAP DRILL SIZE				TIGHTENING TORQUE (INCH - POUNDS)
			WITH USE OF REAMER		WITHOUT USE OF REAMER		
1/16	27	5/32	-	0.234	-	0.246	120
1/8	27	3/16	21/64	0.328	-	0.339	200
1/4	18	1/4	27/64	0.422	7/16	0.438	480
3/8	18	5/16	9/16	0.562	37/64	0.578	960
1/2	14	3/8	11/16	0.688	45/64	0.703	1440
3/4	14	9/16	57/64	0.891	59/64	0.922	2400
1	11-1/2	5/8	1-1/8	1.125	1-5/32	1.156	3360
1-1/4	11-1/2	3/4	1-15/32	1.469	1-1/2	1.500	4320
1-1/2	11-1/2	1	1-45/64	1.703	1-47/64	1.734	5520
2	11-1/2	1	-	-	-	-	6800

SUGGESTED TWIST DRILL DIAMETERS FOR DRILLED HOLE SIZES FOR DRYSEAL PIPE THREADS

The drill diameters given are for tapered internal pipe threads and will usually permit the tapping of acceptable threads in free-machining brass or steel provided the drill is correctly sharpened. When hard metals or other similar materials are to be drilled and tapped, it may be necessary to use a drill of slightly smaller diameter whereas soft materials may require a larger size.

Tapered pipe threads of improved quality are obtained when the holes are taper reamed after drilling and before tapping. Standard taper pipe reamers are used. As in drilling, the actual size of the hole depends upon the material and is best determined by trial.

HOLO-KROME COATED PRESSURE PLUGS



EXPLODED TOP VIEW OF
TAPER TAPPED HOLE

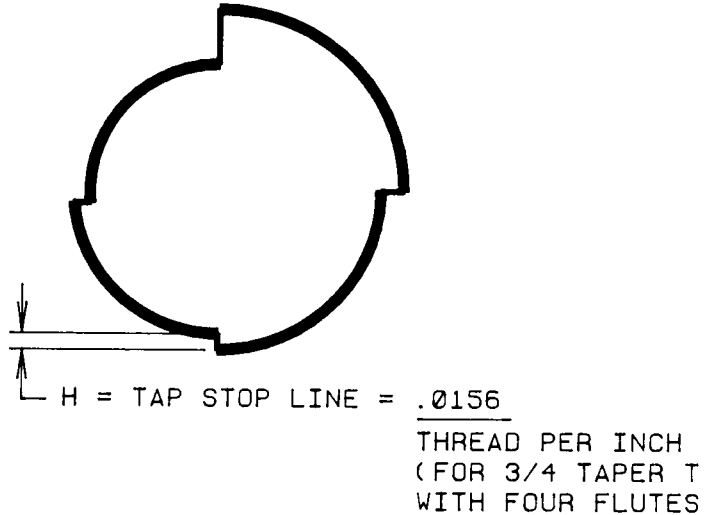

For problem applications Holo-Krome can supply 7/8 taper plugs with either the exclusive Holo-Krome Holo-Seal® finish or with Teflon® type coating.

Holo-Krome has done extensive testing to find the best type of Fluorocarbon (Teflon®) coating available for the plugs. Since this is an ongoing study there will probably be periodic improvements to the coating. The coating criteria are lubricity, corrosion resistance, chemical inertness and heat resistance. Although Fluorocarbon coated plugs have been tested in the Holo-Krome laboratory to 15,000 psi, their ability to withstand service pressures depends entirely on the application parameters.

Holo-Seal® was developed to be used as a substitute for Teflon. It was developed initially for applications where the lubricity of the Teflon allowed the plug to damage the tapped hole. Because of its lower cost and excellent sealing characteristics it is usually preferred to Teflon.

The application advantages of either type of coated plug over tapping and applying gunk to the threads is obvious. When in place cost or cost to replace leaking plugs is considered, precoated plugs are usually the least expensive alternative.

HOLO-KROME COATED PLUG PROPERTIES

Fluorocarbon Type:

Low Coefficient of friction 0.05 - 0.07.

Resistant to corrosion, abrasion.

Resistant to oils, alcohols, dilute acids, common solvents.

Dry and clean.

Service temperature to 300°F (150°C)

Holo-Seal Type:

Coefficient of friction equal to plain black plug.

Resistant to oil, dilute acids, many common solvents.

Dry and clean.

Service temperature to 300°F (150°C).

Can withstand hydraulic pressures to 10,000 psi.

TABLE 34 HOLO-KROME DOWEL PINS



MECHANICAL PROPERTIES

Standard Holo-Krome Dowel Pins are manufactured from Holo-Krome analysis High Grade Alloy Steels heat treated to a core hardness of HRC 47-58 for toughness and strength and a surface hardness of HRC 60 minimum for wear resistance. Case depth to be 0.020" min.

CAUTION: Holo-Krome recommends dowel pins be inserted by application of a constant pressure, with the pin being shielded in case of fracture. A striking force can cause the pin to shatter.

TABLE 34 HOLO-KROME DOWEL PINS MECHANICAL PROPERTIES

NOMINAL SIZE	SINGLE SHEAR STRENGTH (POUNDS)	DOUBLE SHEAR STRENGTH (POUNDS)	RECOMMENDED HOLE SIZE FOR STANDARD PINS	
			MAX.	MIN.
1/8	1,840	3,680	0.1250	0.1245
3/16	4,150	8,300	0.1875	0.1870
1/4	7,360	14,720	0.2500	0.2495
5/16	11,500	23,000	0.3125	0.3120
3/8	16,550	33,100	0.3750	0.3745
7/16	22,550	45,100	0.4375	0.4370
1/2	29,450	58,900	0.5000	0.4995
5/8	46,000	92,000	0.6250	0.6245
3/4	66,200	132,400	0.7500	0.7445
7/8	90,200	180,400	0.8750	0.8745
1	117,800	235,600	1.0000	0.9995

HOLO-KROME NYLOK® HEX-SOCKET SCREWS

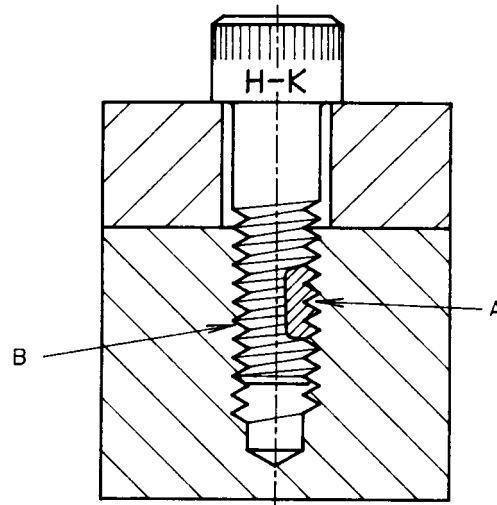

HOW NYLON ELEMENTS LOCK

The locking element is a tough, resilient nylon coating (A) permanently applied to a section of the thread. As the screw is inserted, the mating threads are forced tightly together. A wedging action is created which sets up a strong lateral counterthrust, locking the threads at (B) opposite the coating in a strong metal-to-metal grip. Locking occurs whether the screw is seated or not.

The Nylok Corporation is the originator of the NYLOK (R) process, by which any threaded part can be made self-locking. The Nylok self-locking method consists of a nylon patch, strip or pellet, permanently bonded onto or embedded into the threads of any fastener.

Whether your application requires patch, pellet or strip, this method provides a degree of holding power not otherwise possible. The principle is the same for all three types. When mating threads are engaged, the tough, resilient nylon element is compressed, and, with all of the clearances thereby closed, a strong counterforce is established, which creates a metal-to-metal contact, which not only locks, but also gives sealing properties and sets up a positive resistance to vibration.

The nylon element has a strong memory, and will return to its original shape after removal, providing an excellent degree of re-usability for the system. It retains its high strength properties at temperatures up to 250° F, and is virtually unaffected by alcohol, gasoline, caustic soda, and most commercial solvents. This element can be added to standard parts, or built into any special fasteners when needed. Holo-Krome Engineers will be happy to recommend the proper locking method for any specific application, based on such factors as type of material, complexity of the parts, hardness, wall thickness, etc. Please contact the Holo-Krome Engineering department for assistance in adapting the Nylok self-locking fastening method to your application.

RECOMMENDATIONS FOR PROPER APPLICATION OF HOLO-KROME NYLON INSERT SOCKET SCREWS

The Basic Function of the Holo-Krome Nylon-modified self-locking screw is to induce greater friction between the mating external and internal threads, thereby providing a self-locking holding action. It is, therefore, extremely important to convey the fact that the internal mating thread has a direct effect on the function of the induced locking torque and reusability of the screw and, if improperly tapped, can actually cause failure of the self-locking element. For most effective performance the following precautions and suggestions should be observed, and recommendations as noted herein should be followed:

1. To provide proper entry of the modified screw into the internal thread and to prevent possible shearing of the nylon before thread engagement,

the leading edge of the internal thread should be countersunk approximately 90° x 1/32" in diameter larger than the thread major diameter.

2. The clearance hole (when required) for the shank of the screw should be at least 0.015 larger than the thread major diameter to allow the modified screw to pass through freely. (See page 51 for recommended drill size for shank.)

3. To assure complete utilization of the tensile strength of the screw, the self-locking area should be engaged at least two full threads beyond the starting thread of the tapped hole.

4. The mating internal thread should be clean and smooth. Sharp thread burrs (from improper tapping, etc.) may reduce reusability of the screw by tearing or shearing the nylon.

5. The internal thread should be within Class 2B or 3B limits. Within these limits, the greater the percentage of full thread, the higher the self-locking torque attained. However, the percentage of full thread appears to have little effect on the limits of reusability. Therefore, a variation in torque can be attained by increasing or decreasing the tap drill size. Best results have been attained by using a tap drill size which results in a 75% to 83% full thread.

6. Since increased friction is the main function of the Nylon modification, and lubrication reduces friction, the presence of a lubricant in the assembly will tend to reduce the self-locking torque. (A short air blast is usually sufficient to remove excessive lubrication before assembly.)

7. When using Nylon modified screws in soft materials other than steel (aluminum, brass, etc.) where the normal induced torque may cause damage to the internal threads, it is advisable to reduce the percentage of full thread of the internal member. If the torque still remains too high, it is recommended that the Holo-Krome Engineering Department be consulted relative to special pelleting dimensions to meet requirements.

8. An excessive out-of-round condition of the internal thread will cause erratic induced torque and can lead to reduced holding power and reusability. This condition is easily noticeable by high-low torque readings approximately 90° apart.

HOLO-KROME NYLOK®* HEX-SOCKET SCREWS

PREVAILING TORQUE PER IFI-124 (EXTERNAL THREADS) inch - pounds exc. as noted

THREAD SIZE	0	2	4	6	8	10	1/4	5/16	3/8	7/16	1/2	9/16	5/8	3/4	7/8	1"
INITIAL INSTALLATION (MAX.)	0.75	2	5	8	12	18	40	85	110	150	220	270	350	460	700	900
FIRST REMOVAL (MIN.)	1.5*	3*	1	2	2.5	3	5	8	14	20	26	35	45	60	95	130
FIFTH REMOVAL (MIN.)	0.5*	1.5*	.5	1	1.5	2	3	5	9	12	16	22	30	45	65	85

*Torque values in inch ounces
Torque values in inch pounds

PREVAILING TORQUE PERFORMANCE PER MIL-F-18240 (EXTERNAL THREADS) (inch - pounds)

THREAD SIZE	4	6	8	10	1/4	5/16	3/8	7/16	1/2	5/8
MAXIMUM TORQUE INSTALLATION OR REMOVAL	3	6	9	13	30	60	80	100	110	300
MINIMUM BREAKAWAY TORQUE 15 REMOVALS	0.5	1.0	1.5	2.0	3.5	6.5	9.5	14	18	32

NYLON MODIFIED FASTENERS have been tested and approved to meet the standards of Specification MIL-F-18240 and are approved for aircraft and aerospace use. No need for cross-drilling, lock wiring, etc.

Hex Socket
Set Screw
Cup Point
MS 18063 (steel)
MS 18064 (cres)

Hex Socket
Set Screw
Flat Point
MS 18065 (steel)
MS 18066 (cres)

Hex Socket
Set Screw
Cone Point
MS 18067 (steel)
MS 18068 (cres)



TABLE 35

FASTENER RELATED STANDARDS

ANSI or ASME/ANSI

B1.1	Unified Inch Screw Threads (UN and UNR Thread Form)
B1.2	Gages and Gaging for Unified Screw Threads
B1.3	Screw Thread Gaging Systems
B1.7	Nomenclature, Definitions, and Letter Symbols for Screw Threads
B18.3	Socket Cap, Shoulder and Set Screws
B18.8.2	Machine Pins (Dowel, Taper, Grooved)
B18.12	Glossary of Terms for Mechanical Fasteners
B18.13	Screw and Washer Assemblies-Sems
B18.21.1	Lock Washers
B18.22.1	Plain Washers
B18.23.1	Beveled Washers
B1.20.3	Dryseal Pipe Threads (Inch)
B2.1	Pipe Threads (Except Dryseal)
B2.2	Dryseal Pipe Threads

ASTM

A574	Alloy Steel Socket Head Cap Screws
F837	Stainless Steel Socket Head Cap Screws
F835	Alloy Steel Button Head and Flat Head Cap Screws
F879	Stainless Steel Button Head and Flat Head Cap Screws
F912	Alloy Steel Set Screws
F880	Stainless Steel Set Screws

FEDERAL

FF-S-86	Socket Head Cap Screws
FF-S-200	Set Screws, Hexagon and Spline Socket, Headless
GGG-K-275	Wrench, Hexagon, Spline and Square (with Amend. 1)
QQ-P-35	Passivation Treatment for Austenitic, Ferritic & Martensitic Corrosion-Resisting Steel
QQ-P-416	Plating, Cadmium (Electrodeposited)
QQ-Z-325	Zinc Plating (Electrodeposited)
GGG-W-641	Wrench, Socket, (and socket handles, and attachments for socket wrenches: hand)

TABLE 35 (continued)

MILITARY

MIL-P-21143	Pins Straight, Headless (Dowel)
MIL-S-21472	Screw Shoulder, Hexagon Socket Head
MS-16555	Pin, Dowel, Hardened & Ground (Standard Diameter)
MS-16556	Pin, Dowel, Hardened & Ground (Oversized Diameter)
MS-16995	Screw, Cap, Socket Head, Stainless Steel, UNC
MS-16996	Screw, Cap, Socket Head, Stainless Steel, UNF
MS-16997	Screw, Cap, Socket Head, Alloy Steel, UNC
MS-16998	Screw, Cap, Socket Head, Alloy Steel, UNF
MS-24677,	Screw, Cap, Socket Head, Hexagon Drilled Alloy Steel, UNC
MS-24678	Screw, Cap, Socket Head, Hexagon Drilled Alloy Steel, UNF
MS-24667,	Screw, Cap, Socket Head Flat Countersunk 82° Cad Plated
MS-24671	Screw, Cap, Socket Head Flat Countersunk 82° CRES
MS-24673	Screw, Cap, Socket Head, Stainless Steel, Cross Drilled, UNF
MS-24674	Screw, Cap, Socket Head, Stainless Steel, Cross Drilled, UNC
MS-51963,	Set-Screw - - Hexagon Socket, Cup Point, Cad. Plated, UNC
MS-51964	Set-Screw - - Hexagon Socket, Cup Point, Cad. Plated, UNF
MS-51965,	Set-Screw - - Hexagon Socket, Flat Point, Cad. Plated, UNC
MS-51966	Set-Screw - - Hexagon Socket, Flat Point, Cad. Plated, UNF
MS-51973,	Set-Screw - - Hexagon Socket, Cone Point, Cad. Plated, UNC
MS-51974	Set-Screw - - Hexagon Socket, Cone Point, Cad. Plated, UNF
MS-51976,	Set-Screw - - Hexagon Socket, Half Dog Point, UNC
MS-51977	Set-Screw - - Hexagon Socket, Half Dog Point, UNF
MS-51981,	Set-Screw - - Hexagon Socket, Oval Point, UNC
MS-51982	Set-Screw - - Hexagon Socket, Oval Point, UNF
MS-51053	Set-Screw, Fluted Socket, Alloy Steel, Cad. Plated NC-3A
MS-51975	Screw, Shoulder-Socket Head, Hexagon, Alloy Steel, Cad. Plated UNC-3A
MIL-S-7742B	Screw Threads, Standard, Optimum Selected Series: General Spec. for
MIL-S-8879A	Screw Threads, Controlled Radius Root with Increased Minor Diameter, General Spec. for
MIL-C-13924	Coating, Oxide, Black for Ferrous Metals
MIL-P-16232	Phosphate Coatings, Heavy, Manganese or Zinc Base (For Ferrous Metals)
MIL-F-18240	Fastener, Externally Threaded, 250° Self-Locking Element for

A.I.A.

NAS1351	Screw Cap Socket Head, UNF
NAS1352	Screw Cap Socket Head, UNC

**APPENDIX
GENERAL APPLICATION DATA**

	Page
GLOSSARY OF TERMS	49
TAPPING INFORMATION	51
FASTENER JOINT DESIGN	52
FASTENER STRENGTHS	53
HARDNESS CONVERSIONS	55
EFFECTS OF ALLOYING ELEMENTS	56

GLOSSARY OF TERMS

Tensile Strength - Force or stress required to break a fastener when pulled in straight tension. When expressed as a force, lbs., it applies to a specific size part. Expressed as a stress, psi, means the force is applied over a specific area and it could apply to a range of sizes. For example, socket screws from #0 to 1/2 inch can withstand an applied stress of 180,000 psi.

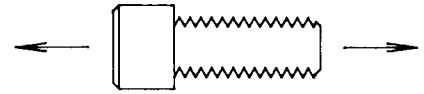

Stress Area - Theoretical area in the thread section of a fastener over which the load is applied.

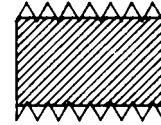

Yield Strength - This is the measure of the resistance of a material to plastic (permanent) deformation. It is usually at a point of 0.2% permanent strain.

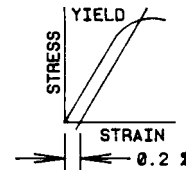

Torsion - Twisting force applied to a fastener during tightening.

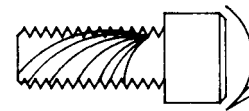

Elongation - longitudinal stretching of a fastener caused by a tensile load due either to tightening or to the external load.

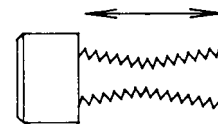

Shear Strength - the resistance of a fastener to transverse loading. This type of load should only be applied to a dowel pin or the unthreaded section of a screw.

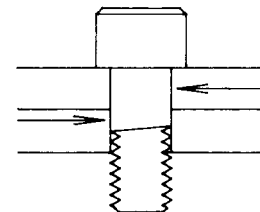

Rockwell Hardness - One method of measuring hardness of a metal, generally related to the material tensile strength. Normally stated as "C" scale readings, but may be taken as "A", 30N or 15N scale readings when limited penetration is desired. Limited penetration is required when checking case hardness or thin parts.

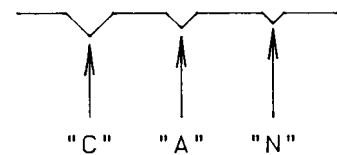

Creep Strength - At elevated temperatures metal under stress elongates. This elongation increases with time and temperature. To prevent failure it is often necessary to change to heat resistant materials.

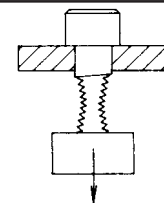

Fatigue Strength - Under variations in applied stress a fastener feels internal stretching that can cause rupture after a specific number of cycles. The number of cycles to failure for a specific load is the fatigue life of the screw. In rigid assemblies preloading above the external load should eliminate fatigue failure.

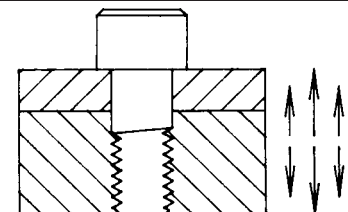

GLOSSARY OF TERMS

Seams - Inherent discontinuities in raw materials that run longitudinally. They are folds in the material, not fractures at the grain boundary.

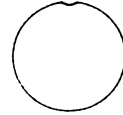

Cracks - Fractures passing through or across grain boundaries without the inclusion of foreign elements.

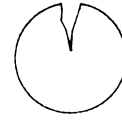

Shank - Portion of a fastener between the head and point.

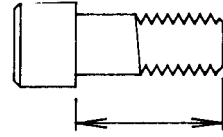

Body - The unthreaded section between the head and threads.

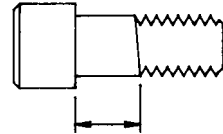

Fillet - Concave junction between the head and shank.

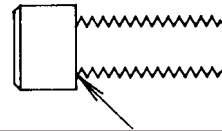

Bearing Surface - Supporting or locating surface of a fastener with respect to the part which it fastens.

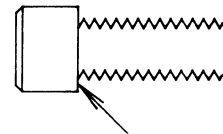

Pressure Flanks - Flank of thread that faces the head of the fastener and which applies the load to the internal threads.

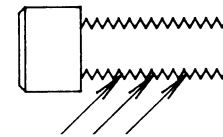

Major Diameter - Largest diameter of the thread.

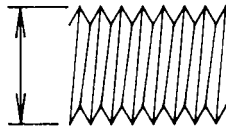

Minor Diameter - Smallest Diameter of a thread.

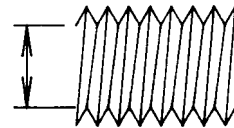

Pitch Diameter - Theoretical diameter at which the thread and thread space are of equal thickness.

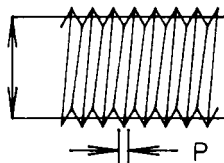

Root - The base of the V thread. Holo-Krome produces parts with radiused root threads.

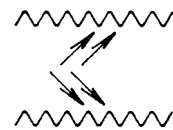

Runout Threads - The thread section that is between the full thread and the fillet or body. Holo-Krome specifies special dies to produce a large radius in this area thus increasing fatigue life.



Standard Fastener - Product represented by standardized dimensions.

Stock Fasteners - Product commercially available at the distribution level. See Holo-Krome's current catalog for stock sizes.

TAPPING HINTS

There are two basic factors to consider in tapped hole strength and cost. These are hole depth and tap drill diameters. The deeper the hole the greater the tapping time and tool breakage. The smaller the tap drill diameter the greater the power required to tap and the higher the tap breakage.

Generally the following minimum engagement lengths are used.

Hardened Steel - 1 diameter

Soft Steel-Cast Iron - 1.5 diameters

Aluminum-Plastic - 2 diameters

These values vary slightly depending on the percent thread tapped.

DRILLING DEPTHS FOR TAPPING BLIND HOLES

The minimum depth of a drilled hole for tapping equals the full thread depth plus the number of turns P (pitch) for each style and size of tap.

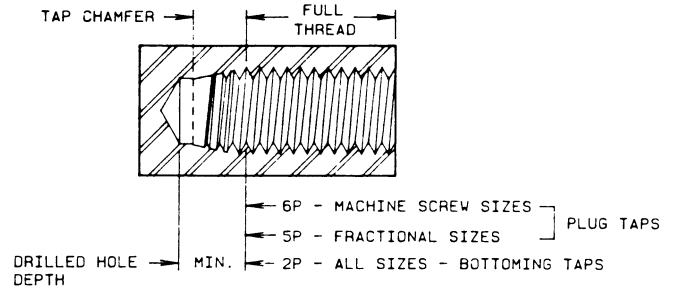

TABLE A-1 COMMON TAP DRILL SIZES

INCH

DIAMETER	UNC	UNF	DRILL (IN.) DEC.	WIRE, LETTER, FRACTIONAL
	PITCH (TPI)			
#0		80	0.0465	#56
#1	64	72	0.0595	#53
		64	0.0595	#53
#2	56	64	0.070	#50
		64	0.070	#50
#3	48	56	0.0785	#47
		56	0.082	#45
#4	40	48	0.0890	#43
		48	0.0935	#42
#5	40	44	0.1015	#38
		44	0.1040	#37
#6	32	40	0.1065	#36
		40	0.1130	#33
#8	32	36	0.1360	#29
		36	0.1360	#29
#10	24	32	0.1495	#25
		32	0.1590	#21
0.250	20	28	0.2040	#6
		28	0.2187	7/32
0.3125	18	24	0.261	G
		24	0.272	I
0.375	16	24	0.313	5/16
		24	0.332	Q
0.4375	14	20	0.3680	U
		20	0.3906	25/64
0.500	13	20	0.4219	27/64
		20	0.4531	29/64
0.5625	12	18	0.4847	31/64
		18	0.512	13mm
0.625	11	18	0.5469	35/64
		18	0.5781	37/64
0.750	10	16	0.6562	21/32
		16	0.6875	11/16
0.875	9	14	0.7656	49/64
		14	0.8125	13/16
1.000	8	12	0.875	7/8
		12	0.9129	59/64
1.250	7	12	1.1094	1-7/64
		12	1.1719	1-11/64
1.500	6	12	1.3437	1-11/32
		12	1.4219	1-27/64

METRIC

DIAMETER	THREAD PITCH	DRILL (MM)
M1.6	0.35	1.25
M2	0.4	1.6
M2.5	0.45	2.05
M3	0.5	2.5
M4	0.7	3.3
M5	0.8	4.2
M6	1.0	5.0
M8	1.25	6.7
M10	1.5	8.5
M12	1.75	10.2
M14	2.0	12.0
M16	2.0	14.0
M20	2.5	17.5
M24	3.0	21.0
M30	3.5	26.5
M36	4.0	32.0
M42	4.5	27.5

FASTENER JOINT DESIGN

In applications which experience high cyclic loading analysis of the fastener loading is critical. Based on the relative stiffness of the assembly and the screw, and the external load applied, the fastener size and proper preload can be determined.

Preload is normally achieved by tightening the screw. The torque required to achieve the specific preload depends on the surface lubricity at the threads and at the head, the surface finish, thread pitch, head bearing configuration, and torque wrench accuracy.

PRELOAD AND EXTERNAL LOAD CONSIDERATIONS

When a fastener is tightened, the load on the assembly and fastener increase. In the ideal case, the screw stretches, and the joint compresses, within the elastic limit, according to Hooke's Law.

Suppose a joint has been tightened to a preload P_i and additional load, P_e , tending to separate the members is applied. In general in rigid assemblies, as long as the external load is less than P_i , it primarily decompresses the joint and has little effect on the tension in the screw. Thus even if such a load is repeatedly applied, the fastener will not fail in fatigue. However, if a repeated external load greater than P_i must be applied, it should be kept to a minimum, since it produces cyclic tensioning in the screw and may lead to fatigue failure.

This principle has important practical applications. Often when fasteners fail, the solution used is to switch to the next larger size. This involves changing the tooling for hole preparation and tightening, and possibly changing assembly fixtures. Most likely, merely tightening the fastener above the external load would solve the problem. For instance, a 180,000 psi tensile strength socket screw has an average endurance limit of only 15,000 psi. This means that the fastener is capable of withstanding a maximum one-time applied stress of 180,000 psi, but that a stress change felt by the fastener of more than 15,000 psi could result in a fatigue failure within a given number of cycles.

A conservative formula giving the tension on a fastener which has an external load, P_e is:

$$P_t = P_i + \left[\frac{K_s}{K_s + K_c} \right] P_e$$

Nomenclature

P_t	=	Total Bolt load, lb.
P_i	=	Preload, lb.
P_e	=	External load, lb.
K_s	=	Screw spring constant, lb./inch.
K_c	=	Assembly spring constant, lb./inch.

The spring constant, K, for a member is given by:

$$\frac{(\text{area, sq. in.}) (\text{modulus of elasticity, psi})}{(\text{length, in.})}$$

Since these calculations ignore factors such as bending, heat, and impact loading, they are useful as a guide only.

Torque to achieve preload

When screws are torqued to achieve preload, the torsional stresses on them reduces the total tensile force they can withstand before yielding. The following formula can be used to determine the effect of this torsional component:

$$S_t = \frac{P}{A} \pm \sqrt{\left(\frac{P}{2A}\right)^2 + \left(\frac{t \times r}{J}\right)^2}$$

The desired tightening torque can be estimated using the empirical formula:

$$T = KDP$$

Nomenclature

S_t	=	Total tensile stress felt by bolt, psi
P	=	Preload exerted by bolt, lb.
A	=	Thread stress area, sq. inches
T	=	Tightening torque, in.-lb.
t	=	Torsion felt by screw (approximately 40% of applied torque, depending on lubricity), in.-lb.
r	=	$\sqrt{A/\pi}$
J	=	$\frac{\pi r^4}{2}$ (polar moment of inertia), in. ⁴
K	=	Constant from 0.05 to 0.35, dimensionless
D	=	Nominal screw diameter, inches

The constant, K , is normally from 0.19 to 0.25 for a black screw. For a lubricated fastener or one with cadmium plating, K is from 0.13 to 0.17. Zinc plated screws, not lubricated, may have a K value as high as 0.30 to 0.35.

For rigid parts of steel, the conservative practice is to tighten the fasteners to 75% of yield. Lower torques should be considered for flexible joints, joints with gaskets, or assemblies subject to high temperatures.

Joint Design Steps

1. Calculate the assembly service load.
2. Determine relative loading on each fastener.
3. Determine the style fastener desired (hex, socket, etc.).
4. Using the highest loaded fastener in assembly, apply an appropriate safety factor based on the estimated reliability of the service load value, the quality level of the type fastener used, estimate of assembly techniques consistency, and danger of an assembly failure. Normally a safety factor could range from 1.5 to 6.
5. Determine fastener size, tightening torque, and cycle life, where applicable.
6. Specify tightening torques on drawing.





Fastener Assembly Tips:

1. Preload properly.
2. Do not use split type lock washers on socket head screws or Grade 8 hex screws.
3. Use long screws when possible.
4. Avoid transverse or shear loading against the threads.
5. Keep the members clean during assembly.
6. Use wrenches that fit properly and are correctly heat treated.

TABLE A2 FASTENER STRENGTHS

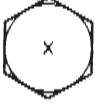
Fasteners are marked to indicate various strength levels to which they are manufactured. They are also required to have manufacturer's identification marks.

TABLE A2 FASTENER STRENGTHS INCH

IDENTIFICATION GRADE MARK	SPECIFICATION	FASTENER DESCRIPTION	MATERIAL	NOMINAL SIZE RANGE (IN.)	MECHANICAL PROPERTIES		
					PROOF LOAD (psi)	YIELD STRENGTH MIN. (psi)	TENSILE STRENGTH MIN. (psi)
	Grade 2	Bolts, Screws, Studs	Low or Medium Carbon Steel	1/4 through 3/4 Over 3/4 to 1-1/2	55,000 33,000	57,000 36,000	74,000 60,000
	Grade 5	Bolts, Screws, Studs	Medium Carbon Steel Quenched and Tempered	1/4 through 1 Over 1 through 1-1/2 Over 1-1/2 through 3	85,000 74,000 55,000	92,000 81,000 58,000	120,000 105,000 90,000
	Grade 8	Bolts, Screws, Studs	Medium Carbon Alloy Steel. Quenched and Tempered	1/4 through 1-1/2	120,000	130,000	150,000
	Socket Screw	Socket Head Cap Screws	Alloy Steel. Quenched and Tempered	#0 through 1/2 Over 1/2 through 2		162,000 153,000	180,000 170,000

X = MANUFACTURER'S MARK

METRIC

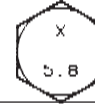
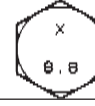
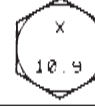
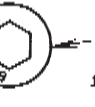
IDENTIFICATION GRADE MARK	SPECIFICATION	FASTENER DESCRIPTION	MATERIAL	PROOF LOAD	MECHANICAL PROPERTIES	
					MIN. (MPa)	
					YEILD STRENGTH	TENSILE STRENGTH
	Class 5.8	Bolts, Screws, Studs	Low or Medium Carbon Steel	380	420	520 (75,900 psi)
	Class 8.8	Bolts, Screws, Studs	Medium Carbon Steel Quenched and Tempered	600	640	830 (120,000 psi)
	Class 10.9	Bolts, Screws, Studs	Medium Carbon Alloy Steel. Quenched and Tempered	830	940	1040 (150,000 psi)
	Class 12.9	Socket Head Cap Screws*	Alloy Steel. Quenched and Tempered	970	1100	1220 (177,000 psi)

X = MANUFACTURER'S MARK

***NOTE:**

Socket Head Cap Screws of Property Class 12.9 are comparable (177 ksi vs. 180 ksi) to the USA standard. However, in Europe particularly, and elsewhere, they may be made in Classes 5.8, 8.8, or 10.9, all of which are significantly weaker than the 12.9. It is critical that any replacement Socket Head Cap Screws be of equal strength to those removed. Beware of substitutions of a lower grade which could lead to catastrophic failure.

METRIC CONVERSIONS

TABLE A3 CONVERSION TABLE
Fractional Inch to Decimal Inch and Millimeters

FRAC-TIONAL INCH	DECIMAL INCH	MILL-METERS	FRAC-TIONAL INCH	DECIMAL INCH	MILL-METERS
1/64	0.015625	0.3969	33/64	0.515625	13.0969
1/32	0.03125	0.7937	17/32	0.53125	13.4937
3/64	0.046875	1.1906	35/64	0.546875	13.8906
1/16	0.0625	1.5875	9/16	0.5625	14.2875
5/64	0.078125	1.9844	37/64	0.578125	14.6844
3/32	0.09375	2.3812	19/32	0.59375	15.0812
7/64	0.109375	2.7781	39/64	0.609375	15.4781
1/8	0.125	3.1750	5/8	0.625	15.8750
9/64	0.140625	3.5719	41/64	0.640625	16.2719
5/32	0.15625	3.9687	21/32	0.65625	16.6687
11/64	0.171875	4.3656	43/64	0.671875	17.0656
3/16	0.1875	4.7625	11/16	0.6875	17.4625
13/64	0.203125	5.1594	45/64	0.703125	17.8594
7/32	0.21875	5.5562	23/32	0.71875	18.2562
15/64	0.234375	5.9531	47/64	0.734375	18.6531
1/4	0.25	6.3500	3/4	0.75	19.0500
17/64	0.265625	6.7469	49/64	0.765625	19.4469
9/32	0.28125	7.1437	25/32	0.78125	19.8437
19/64	0.296875	7.5406	51/64	0.796875	20.2406
5/16	0.3125	7.9375	13/16	0.8125	20.6375
21/64	0.328125	8.3344	53/64	0.828125	21.0344
11/32	0.34375	8.7312	27/32	0.84375	21.4312
23/64	0.359375	9.1281	55/64	0.859375	21.8281
3/8	0.375	9.5250	7/8	0.875	22.2250
25/64	0.390625	9.9219	57/64	0.890625	22.6219
13/32	0.40625	10.3187	29/32	0.90625	23.0187
27/64	0.421875	10.7156	59/64	0.921875	23.4156
7/16	0.4375	11.1125	15/16	0.9375	24.8125
29/64	0.453125	11.5094	61/64	0.953125	24.2094
15/32	0.46875	11.9062	31/32	0.96875	24.6062
31/64	0.484375	12.3031	63/64	0.984375	25.0031
1/2	0.50	12.7000	1	1.00	25.4000

TABLE A4 CONVERSION TABLE
Millimeters to Inches

MILLI-METERS	INCH	MILLI-METERS	INCH	MILLI-METER	INCH
1	0.0394	34	1.3386	67	2.6378
2	0.0787	35	1.3779	68	2.6772
3	0.1181	36	1.4173	69	2.7165
4	0.1575	37	1.4567	70	2.7559
5	0.1968	38	1.4961	71	2.7953
6	0.2362	39	1.5354	72	2.8346
7	0.2756	40	1.5748	73	2.8740
8	0.3150	41	1.6142	74	2.9134
9	0.3543	42	1.6535	75	2.9527
10	0.3937	43	1.6929	76	2.9921
11	0.4331	44	1.7323	77	3.0315
12	0.4724	45	1.7716	78	3.0709
13	0.5118	46	1.8110	79	3.1102
14	0.5512	47	1.8504	80	3.1496
15	0.5905	48	1.8898	81	3.1890
16	0.6299	49	1.9291	82	3.2283
17	0.6693	50	1.9685	83	3.2677
18	0.7087	51	2.0079	84	3.3071
19	0.7480	52	2.0472	85	3.3464
20	0.7874	53	2.0866	86	3.3858
21	0.8268	54	2.1260	87	3.4252
22	0.8661	55	2.1653	88	3.4646
23	0.9055	56	2.2047	89	3.5039
24	0.9449	57	2.2441	90	3.5433
25	0.9842	58	2.2835	91	3.5827
26	1.0236	59	2.3228	92	3.6220
27	1.0630	60	2.3622	93	3.6614
28	1.1024	61	2.4016	94	3.7008
29	1.1417	62	2.4409	95	2.7401
30	1.1811	63	2.4803	96	3.7795
31	1.2205	64	2.5197	97	3.8189
32	1.2598	65	2.5590	98	3.8583
				99	3.8976
33	1.2992	66	2.5984	100	3.9370

1 millimeter = .03937 inch.
 1 inch = 25.4 millimeter.

TABLE A5
NUMBER DRILL SIZES TO DECIMAL INCH

80	.0135	70	.0280	60	.0400	50	.0700	40	.0980	30	.1285	20	.1610	10	.1935
79	.0145	69	.0292	59	.0410	49	.0730	39	.0995	29	.1360	19	.1660	9	.1960
78	.0160	68	.0310	58	.0420	48	.0760	38	.1015	28	.1405	18	.1695	8	.1990
77	.0180	67	.0320	57	.0430	47	.0785	37	.1040	27	.1440	17	.1730	7	.2010
76	.0200	66	.0330	56	.0465	46	.0810	36	.1065	26	.1470	16	.1770	6	.2040
75	.0210	65	.0350	55	.0520	45	.0820	35	.1100	25	.1495	15	.1800	5	.2055
74	.0225	64	.0360	54	.0550	44	.0860	34	.1110	24	.1520	14	.1820	4	.2090
73	.0240	63	.0370	53	.0595	43	.0890	33	.1130	23	.1540	13	.1850	3	.2130
72	.0250	62	.0380	52	.0635	42	.0935	32	.1160	22	.1570	12	.1890	2	.2210
71	.0260	61	.0390	51	.0670	41	.0960	31	.1200	21	.1590	11	.1910	1	.2280

LETTER DRILL SIZES TO DECIMAL INCH

A	.234	D	.246	G	.261	J	.277	M	.295	P	.323	S	.348	W	.386
B	.238	E	.250	H	.266	K	.281	N	.302	Q	.332	T	.358	X	.397
C	.242	F	.257	I	.272	L	.290	O	.316	R	.339	U	.368	Y	.404
												V	.377	Z	.413

TABLE A6 HARDNESS VALUE CONVERSIONS
Hardened Carbon Steel and Hard Alloys

ROCKWELL					KNOOP 500 GR. & OVER	BRINELL 3000 KG†	TENSILE STRENGTH* APPROX.
C	A	15-N	30-N	45-N			
71	87.0	-	86.5	78.5	-	-	-
70	86.5	94.0	86.0	77.5	972	-	-
69	86.0	93.5	85.0	76.5	946	-	-
68	85.6	93.2	84.4	75.4	920	-	-
67	85.0	92.9	83.6	74.2	895	-	-
66	84.5	92.5	82.8	73.3	870	-	-
65	83.9	92.2	81.9	72.0	846	-	-
64	83.4	91.8	81.1	71.0	822	-	-
63	82.8	91.4	80.1	69.9	799	-	-
62	82.3	91.1	79.3	68.8	776	-	-
61	81.8	90.7	78.4	67.7	754	-	-
60	81.2	90.2	77.5	66.6	732	613	-
59	80.7	89.8	76.6	65.5	710	599	326
58	80.1	89.3	75.7	64.3	690	587	315
57	79.6	88.9	74.8	63.2	670	575	305
56	79.0	88.3	73.9	62.0	650	561	295
55	78.5	87.9	73.0	60.9	630	546	287
54	78.0	87.4	72.0	59.8	612	534	278
53	77.4	86.9	71.2	58.6	594	519	269
52	76.8	86.4	70.2	57.4	576	508	262
51	76.3	85.9	69.4	56.1	558	494	253
50	75.9	85.5	68.5	55.0	542	481	245
49	75.2	85.0	67.6	53.8	526	469	239
48	74.7	84.5	66.7	52.5	510	455	232
47	74.1	83.9	65.8	51.4	495	443	225
46	73.6	83.5	64.8	50.3	480	432	219
45	73.1	83.0	64.0	49.0	466	421	212
44	72.5	82.5	63.1	47.8	452	409	206
43	72.0	82.0	62.2	46.7	438	400	201
42	71.5	81.5	61.3	45.5	426	390	196
41	70.9	80.9	60.4	44.3	414	381	191
40	70.4	80.4	59.5	43.1	402	371	186
39	69.9	79.9	58.6	41.9	391	362	181
38	69.4	79.4	57.7	40.8	380	353	176
37	68.9	78.8	56.8	39.6	370	344	172
36	68.4	78.3	55.9	38.4	360	336	168
35	67.9	77.7	55.0	37.2	351	327	163
34	67.4	77.2	54.2	36.1	342	319	159
33	66.8	76.6	53.3	34.9	334	311	154
32	66.3	76.1	52.1	33.7	326	301	150
31	65.8	75.6	51.3	32.5	318	294	146
30	65.3	75.0	50.4	31.3	311	286	142
29	64.7	74.5	49.5	30.1	304	279	138
28	64.3	73.9	48.6	28.9	297	271	134
27	63.8	73.3	47.7	27.8	290	264	131
26	63.3	72.8	46.8	26.7	284	258	127
25	62.8	72.2	45.9	25.5	278	253	124
24	62.4	71.6	45.0	24.3	272	247	121
23	62.0	71.0	44.0	23.1	266	243	118
22	61.5	70.5	43.2	22.0	261	237	115
21	61.0	69.9	42.3	20.7	256	231	113
20	60.5	69.4	41.5	19.6	251	226	110

* Tensile Strength is psi x 1000.

† Values in () below normal value.

** Below Brinell 101 tests were made with 500 kg. load.

Soft Carbon Steel

B ‡	F	ROCKWELL			KNOOP 500 GR. & OVER	BRINELL 3000 KG†	TENSILE STRENGTH* APPROX.	
		15-T30-T45-T		A				
100	-	93.0	82.0	72.0	61.5	251	240	116
98	-	-	81.0	70.0	60.5	241	228	109
96	-	-	80.0	68.0	59.0	231	216	103
94	-	-	78.5	66.0	57.5	221	205	98
92	-	90.5	77.5	64.5	56.5	211	195	93
91	-	-	77.0	63.5	56.0	206	190	91
89	-	89.5	77.5	61.5	55.0	196	180	87
88	-	-	75.0	60.5	54.0	192	176	85
86	-	88.5	74.0	58.5	53.0	184	169	81
84	-	88.0	73.0	57.0	52.0	176	162	78
82	-	-	71.5	55.0	50.5	170	156	75
80	-	86.5	70.0	53.0	49.5	164	150	72
78	-	86.0	69.0	51.0	48.5	158	144	-
76	-	-	67.5	48.0	47.0	152	139	-
75	99.5	85.0	67.0	49.5	46.5	150	137	-
74	99.0	-	66.0	47.5	46.0	147	135	-
72	97.0	84.0	65.0	45.5	45.0	143	130	-
70	98.0	83.5	63.5	43.5	44.0	139	125	-
68	95.5	-	62.0	41.5	43.0	135	121	-
60	94.5	82.0	60.5	39.5	42.0	131	117	-
64	93.5	81.5	59.5	37.5	41.5	127	114	-
62	92.0	-	58.0	35.5	40.5	124	110	-
60	91.0	-	56.5	33.5	39.5	120	107	-
58	90.0	79.5	55.0	31.0	38.5	117	104	-
56	89.0	79.0	54.0	29.0	-	114	101	-
54	87.5	-	52.5	27.0	37.0	111	87**	-
52	86.5	77.5	51.0	25.0	36.0	109	85**	-
50	85.5	77.0	49.5	23.0	35.0	107	83**	-
49	85.0	76.5	49.0	22.0	-	106	82**	-
47	84.0	76.0	47.5	19.5	34.0	104	80**	-
45	82.5	-	46.0	17.5	33.0	102	79**	-
43	81.5	74.5	45.0	15.5	32.0	100	77**	-
41	80.5	74.0	43.5	13.5	31.0	98	75**	-
39	79.0	-	42.0	11.0	30.5	96	74**	-
37	78.0	72.5	40.5	9.0	29.5	94	72**	-
35	77.0	72.0	39.5	7.0	28.5	92	71**	-
33	75.5	-	38.0	5.0	-	90	69**	-
31	74.5	-	36.5	3.0	27.0	88	68**	-
29	73.5	70.0	35.5	1.0	26.0	-	-	-
27	72.5	69.5	34.0	-	25.0	85	-	-
25	71.0	-	32.5	-	-	-	64**	-
23	70.0	68.0	31.0	-	23.0	-	-	-
21	69.0	67.5	29.5	-	22.5	-	62**	-
(19)	68.0	67.0	28.5	-	21.5	79	61**	-
(17)	66.5	-	27.0	-	21.0	-	60**	-
(15)	66.5	66.5	25.5	-	20.0	76	59**	-
(13)	64.5	65.0	24.0	-	-	-	58**	-
(11)	63.5	-	23.0	-	-	73	-	-
(8)	61.5	63.5	20.5	-	-	71	-	-
(7)	61.0	63.0	20.0	-	-	-	56**	-
(2)	58.0	61.5	16.5	-	-	68	54**	-
(0)	57.0	-	15.0	-	-	67	53**	-

1 Conversions are never numerically exact.

2 The approximate tensile strength cross-reference holds for carbon steel only.

3 Further detail may be found by reference to ASTM E-140.

NOTE: The attached paragraph from ASTM F-606 gives both the "normal" and arbitration methods for hardness testing of fasteners.

3. TEST METHODS FOR EXTERNALLY THREADED FASTENERS

3.1 PRODUCT HARDNESS. For routine inspection, hardness of bolts and studs may be determined on the ends, wrench flats, or unthreaded shanks after removal of any oxide, decarburization, plating, or other coating material. Rockwell or Brinell hardness may be used at the option of the manufacturer, taking into account the size and grade of the product. For purpose of arbitration, hardness

shall be determined at mid-radius of a transverse section of the product taken at a distance of one diameter from the point end of the product. The reported hardness shall be the average of four hardness readings located at 90° to one another. The preparation of test specimens and the performance of hardness tests for Rockwell and Brinell testings shall be in conformity with the requirements of Test Methods E 18 and E 10, respectively.

EFFECTS OF ALLOYING ELEMENTS IN STEEL

Steel, by definition, is a combination of iron and carbon. Various other elements are added to steel to improve physical properties and to produce special properties, such as resistance to corrosion or heat. The specific effects of the addition of such elements are outlined below:

ALUMINUM (Al). Aluminum is a deoxidizer and degasifier. It retards grain growth and is used to control austenitic grain size. In nitriding steels, aluminum aids in producing a uniformly hard and strong nitrided case when used in amounts of 1.00% - 1.25%.

BORON (B). A potent and economical addition to a fully deoxidized steel; normally used in alloy steels. Added to the melt in extraordinarily small amounts (on the order of 0.001%), it has a powerful effect on hardenability. During times of shortages of nickel, chromium and molybdenum, boron is used to replace a portion of these elements which are used to increase hardenability. Boron cannot be added in large amounts as it caused hot-shortness (brittleness in steel in the hot forming range).

BISMUTH (Bi). Used in the same manner as lead as an additive in small amounts to improve machinability in the faster machining grades of certain proprietary screw machine steels.

Carbon (C). While carbon is not usually considered an alloying element, it is the most important constituent of steel. It increases the tensile strength, hardness and resistance to wear and abrasion. However, carbon lowers the ductility, machinability and toughness.

CHROMIUM (Cr). Chromium increases tensile strength, toughness, hardness and hardenability, as well as resistance to wear and abrasion. It also increases resistance to corrosion and scaling at elevated temperatures.

COBALT (Co). Cobalt increases strength and hardness in addition to permitting higher quenching temperatures. Also, it intensifies the effects of the other major elements in more complex steels.

COLUMBIUM (Cb). Columbium in stainless steel has an effect similar to titanium and tantalum in making the steel more resistant to carbide precipitation and the resulting inter-granular corrosion.

COPPER (Cu). Copper improves resistance to atmospheric corrosion and increases the tensile and yield strength with very little loss in ductility.

IRON (Fe). Iron is the chief element from which the various steels are made. Pure iron lacks strength, is very soft and ductile and does not respond satisfactorily to heat treatment. Commercial iron normally contains other elements which produce the required physical properties.

LEAD (Pb). Lead, while not strictly an alloying element, is added to improve machinability. It is almost completely insoluble in steel, and minute lead particles, dispersed throughout the steel, reduce friction where the cutting edge contacts the work. Also, the addition of lead improves chip-breaking formations.

MANGANESE (Mn). Manganese is a deoxidizer and degasifier. It also reacts with sulphur to improve forgeability. Manganese increase tensile strength, hardness, hardenability, resistance to wear and the rate of carbon penetration in carburizing. It also decreases the tendency toward scaling and distortion.

MOLYBDENUM (Mo). Molybdenum increase strength, toughness, hardness, and hardenability as well as creep resistance and strength at elevated temperatures. It improves machinability, corrosion resistance and intensifies the effects of the other alloying elements. In hot-work steels, molybdenum increases red-hardness properties.

NICKEL (Ni). Nickel increases strength and hardness with no loss of ductility and toughness. It also increases resistance to corrosion and scaling at elevated temperatures when introduced suitable quantities in high chromium stainless steels.

NITROGEN (N). Important in several respects; 1) as a strong austenitizer which can substitute for a portion of the nickel in stainless steels; 2) as an element in nitriding and carbonitriding certain alloy steels containing aluminum or chromium to produce an extremely hard case; 3) added to the melt of some of the free-machining steels to enhance machinability by producing a vary fine chip.

PHOSPHORUS (P). Phosphorus increases strength and hardness and improves machinability. However, it adds brittleness or cold-shortness to steel.

SELENIUM (Se). Related to sulphur and tellurium in the chemical classification of elements, it has the similar effect of improving machinability when added in small amounts to some free-machining steels.

SILICON (Si). Silicon is a deoxidizer and degasifier. Also, it increases the tensile and yield strength, forgeability, hardness and magnetic permeability.

SULPHUR (S). Sulphur improves machinability in free-cutting steels. It decreases weldability, ductility and impact strength. Also, the addition of sulphur without sufficient manganese produces brittleness at red heat.

TANTALUM (Ta). Tantalum is used as a stabilizing element in stainless steels. It has a high affinity for carbon and forms carbides which are uniformly dispersed throughout the steel, thus preventing localized depletion of carbon at grain boundaries.

TITANIUM (Ti). Titanium, like tantalum and columbium, is added to stainless steels to make them resistant to harmful carbide precipitation.

TUNGSTEN (W). Tungsten increases strength, toughness and hardness. At elevated temperatures tungsten steels have superior hotworking characteristics and greater cutting efficiency.

VANADIUM (V). Vanadium increases strength, hardness, and impact resistance. By retarding grain growth vanadium permits higher quenching temperatures. It also improves the red-hardness properties of high-speed metal cutting tools and intensifies the individual effects of other major elements.

METRIC FASTENERS

TABLE OF CONTENTS

DIMENSIONAL DATA	Page No.
Metric Warning	60
Socket Head Cap Screws-Metric Series	61-64
Metric Socket Button Head Cap Screws	65
Metric Socket Flat Countersunk Head Cap Screws	66,67
Metric Socket Head Shoulder Screws	68,69
Metric Socket Set Screws	70-72
Metric Hexagon and Spline Sockets	73
Metric Allen Wrenches and Bits	74
Metric Allen Spline Keys and Bits	75
Metric Dowel Pins	76
Metric Holo-Krome Thread Standards	77-79
MECHANICAL PROPERTIES AND APPLICATIONS DATA	80
Mechanical Properties and Applications Data	81
Mechanical Properties-Socket Head Cap Screws-Metric Series	82
Torque Data-Socket Head Cap Screws-Metric Series	83
Decarburization and Discontinuity Limits	84
Holo-Krome Stainless Steel Metric Socket Head Cap Screws	85
Holo-Krome Metric Socket Button Head, Metric Socket Flat Countersunk Head Screws	86
Tightening Torque-Metric Socket Button Head, Metric Socket Flat Countersunk Head Screws	86
Mechanical Properties-Metric Socket Shoulder Screws	87
Metric Socket Set Screws-Axial Holding Power	88
Mechanical Properties-Metric Allen Wrenches and Bits	89
Mechanical Properties-Metric Dowel Pins	90
Metric Fastener Related Standards	91

Metric Section

Index to Tables	Page No.
Table 36 Holo-Krome Metric Socket Head Cap Screws-Dimensions	61
Table 37 Holo-Krome Metric Socket Head Cap Screws-Grip and Body Lengths	62
Table 38 Functional Limits for Runout of Head, Body, and Thread on Metric Socket Head Cap Screws	63
Table 39 Drill and Counterbore Sizes-Metric Series	64
Table 40 Metric Hexagon Socket Button Head Cap Screws-Dimensions	65
Table 41 Metric Hexagon Socket Flat Countersunk Head Cap Screws-Dimensions	66
Table 42 Metric Hexagon Socket Flat Countersunk Head Cap Screws-Body and Grip Lengths	67
Table 43 Metric Hexagon Socket Head Shoulder Screws-Dimensions	68
Table 44 Metric Hexagon and Spline Socket Set Screws-Dimensions	70
Table 45 Dimensions of Points of Metric Socket Set Screws	71
Table 46 Dimensions of Metric Spline Sockets	73
Table 47 Dimensions of Metric Hexagon Sockets	73
Table 48 Dimensions of Metric Allen Wrenches and Bits	74
Table 49 Dimensions of Metric Allen Spline Keys and Bits	75
Table 50 Dimensions of Metric Dowel Pins	76
Table 51 Metric Screw Thread Standards	77
Table 52 External Thread-Limiting Dimensions M Profile	78
Table 52A Limit Values for M Profile Minium Rounded Root Radius	78
Table 53 Diameter/Thread Pitch Comparison	79
Table 54 Metric Socket Head Cap Screws, Mechanical Properties	82
Table 55 Metric Socket Head Cap Screws, Tightening Torque Data	83
Table 56 Metric Socket Head Cap Screws, Decarburization Limits	84
Table 57 Metric Socket Head Cap Screws, Stainless Steel, Mechanical Properties	85
Table 58 Metric Button Head, Flat Countersunk Head Socket Cap Screws, Mechanical Properties	86
Table 59 Metric Button Head, Flat Countersunk Head Socket Cap Screws, Tightening Torque	86
Table 60 Holo-Krome Metric Shoulder Screws	87
Table 61 Holo-Krome Metric Set Screws-Axial Holding Power	88
Table 62 Holo-Krome Metric Allen Wrenches and Bits-Mechanical and Application Data	89
Table 63 Holo-Krome Metric Dowel Pins-Mechanical Properties	90
Table 64 Metric Fastener Related Standards	91

Warning Metric Users!

It is very important that the users of Socket Products, particularly Socket Head Cap Screws, be aware that the practice in Europe and other metric areas, is not to restrict the manufacturer of these products to Class 12.9. In the USA, and in inch module parts, it has been customary that the socket head cap screw configuration is always made from alloy steel and always to a

high strength level, typically 180,000 psi. Metric countries produce this same configuration in alloy steels in Class 10.9 as well, and in Class 8.8 from carbon steel. It is vitally important that an assembly designed around Class 12.9 cap screws be put together with such screws. Beware of lower strength screws being substituted.

Holo-Krome Metric Socket Screw Products

TYPE	SIZE RANGE	
	DIAMETER	LENGTH
Socket Head Cap Screw 	M3 to M24	5 to 35mm thru 40 to 150mm
Flat Countersunk Head Socket Screws 	M3 to M20	8 to 30 mm thru 35 to 100mm
Button Head Socket Screws 	M3 to M22	8 to 16mm thru 10 to 40mm
Cup Point Socket Set Screws 	M3 to M16	3 to 16mm thru 20 to 50mm
Hexagon Socket Head Shoulder Screws 	6mm to 16mm	10 to 90mm
Metric Allen Wrenches 	SHORT ARM	LONG ARM
	0.7 to 19mm	0.7 to 19mm

TABLE 36 HOLO-KROME METRIC SOCKET HEAD CAP SCREWS

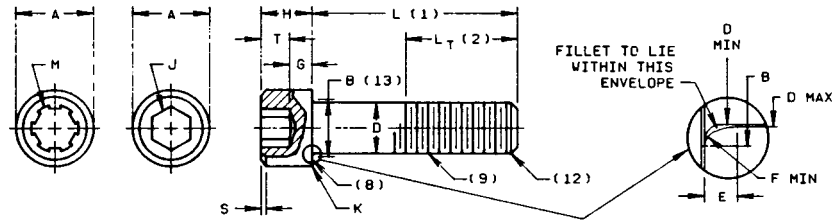

TABLE 36 DIMENSIONS

NOMINAL SIZE AND THREAD PITCH	D		A		H		S	J	M	T	G	UNDERHEAD FILLET			K	L _T	
	BODY DIAMETER		HEAD DIAMETER		HEAD HEIGHT		CHAMFER OR RADIUS	HEXAGON SOCKET SIZE	SPLINE SOCKET SIZE	KEY ENGAGEMENT	WALL THICKNESS	TRANSITION DIAMETER	TRANSITION LENGTH	JUNCTURE RADIUS	CHAMFER OR RADIUS	THREAD LENGTH	
	MAX.	MIN.	MAX.	MIN.	MAX.	MIN.	MAX.	NOM.	NOM.	MIN.	MIN.	MAX.	MIN.	MAX.	MIN.	MAX.	MIN.
M1.6 x 0.35	1.60	1.46	3.00	2.87	1.60	1.52	0.16	1.5	1.829	0.80	0.54	2.0	1.8	0.34	0.10	0.08	15.2
M2 x 0.4	2.00	1.86	3.80	3.65	2.00	1.91	0.20	1.5	1.829	1.00	0.68	2.6	2.2	0.51	0.10	0.08	16.0
M2.5 x 0.45	2.50	2.36	4.50	4.33	2.50	2.40	0.25	2.0	2.438	1.25	0.85	3.1	2.7	0.51	0.10	0.08	17.0
M3 x 0.5	3.00	2.86	5.50	5.32	3.00	2.89	0.30	2.5	2.819	1.50	1.02	3.6	3.2	0.51	0.10	0.13	18.0
M4 x 0.7	4.00	3.82	7.00	6.80	4.00	3.88	0.40	3.0	3.378	2.00	1.52	4.7	4.4	0.60	0.20	0.13	20.0
M5 x 0.8	5.00	4.82	8.50	8.27	5.00	4.86	0.50	4.0	4.648	2.50	1.90	5.7	5.4	0.60	0.20	0.13	22.0
M6 x 1	6.00	5.82	10.00	9.74	6.00	5.85	0.60	5.0	5.486	3.00	2.28	6.8	6.5	0.68	0.25	0.20	24.0
M8 x 1.25	8.00	7.78	13.00	12.70	8.00	7.83	0.80	6.0	7.391	4.00	3.20	9.2	8.8	1.02	0.40	0.20	28.0
M10 x 1.5	10.00	9.78	16.00	15.67	10.00	9.81	1.00	8.0	-	5.00	4.00	11.2	10.8	1.02	0.40	0.20	32.0
M12 x 1.75	12.00	11.73	18.00	17.63	12.00	11.79	1.20	10.0	-	6.00	4.80	14.2	13.2	1.87	0.60	0.25	36.0
M14 x 2 (1)	14.00	13.73	21.00	20.60	14.00	13.77	1.40	12.0	-	7.00	5.60	16.2	15.2	1.87	0.60	0.25	40.0
M16 x 2	16.00	15.73	24.00	23.58	16.00	15.76	1.60	14.0	-	8.00	6.40	18.2	17.2	1.87	0.60	0.25	44.0
M20 x 2.5	20.00	19.67	30.00	29.53	20.00	19.73	2.00	17.0	-	10.00	8.00	22.4	21.6	2.04	0.80	0.40	52.0
M24 x 3	24.00	23.67	36.00	35.48	24.00	23.70	2.40	19.0	-	12.00	9.60	26.4	25.6	2.04	0.80	0.40	60.0
M30 x 3.5	30.00	29.67	45.00	44.42	30.00	29.67	3.00	22.0	-	15.00	12.00	33.4	32.0	2.89	1.00	0.40	72.0
M36 x 4	36.00	35.61	54.00	53.37	36.00	35.64	3.60	27.0	-	18.00	14.40	39.4	38.0	2.89	1.00	0.40	84.0
M42 x 4.5	42.00	41.61	63.00	62.31	42.00	41.61	4.20	32.0	-	21.00	16.80	45.6	44.4	3.06	1.20	0.40	96.0
M48 x 5	48.00	47.61	72.00	71.27	48.00	47.58	4.80	36.0	-	24.00	19.20	52.6	51.2	3.91	1.60	0.40	108.0

(1) The M14x2 size is not recommended for use in new designs.

NOTES FOR TABLE 36

1. LENGTH L. The length of the screw is the distance measured on a line parallel to the axis, from the plane of the bearing surface under the head to the plane of the flat of the point. It includes the threads and the body.
2. THREAD LENGTH L_T. Thread length of the screw is the distance from the extreme point to the last complete or full form thread. It is controlled by the grip length, L_G, as defined below. See Table 37 for grip and body lengths of standard screws. L_T min. refers to screws outside the range of Table 37.
3. BODY L_B. The unthreaded cylindrical portion of the shank for screws that are not threaded to the head.
4. GRIP LENGTH L_G. The maximum length representing the design length of the screw. It is measured from the bearing surface of the head, parallel to the axis of the screw, to the face of a GO thread ring gage with the countersink and/or counterbore removed. See page 62 for grip and body lengths of standard screws.
5. HEAD DIAMETER A. Heads may be made plain or knurled at Holo-Krome's option, unless specified on the order. For knurled screws, the maximum head diameter includes the knurl. Minimum head diameter is the diameter of the head before knurling, or any unknurled section or band on the head. Sizes M5 and larger shall be marked with H-K logo and strength level.
6. HEAD CONCENTRICITY. The heads of Holo-Krome Metric Socket Head Cap Screws are concentric with the shank within 2% of the basic screw diameter, or 0.15mm, whichever is greater, FIM (Full Indicator Movement).
7. SOCKET TRUE POSITION. The axis of the socket shall be located at true position relative to the axis of the screw within a tolerance zone having a diameter equal to 3% of the basic screw diameter or 0.26mm, whichever is greater, for nominal screw sizes up to and including 12mm, and equal to 6% of the basic screw diameter for sizes larger than 12mm—regardless of feature size.

8. BEARING SURFACE. The plane of the bearing surface is perpendicular to the axis of the screw within a maximum deviation of 1 degree.
9. THREADS. Threads are Metric coarse series in accordance with ANSI/ASME B 1.13M - Metric Screw Threads, M Profile.
10. THREAD TOLERANCE CLASS. Threads are Tolerance Class 4g6g and for plated screws the allowance g may be consumed by the thickness of plating, so that the maximum limit of six after plating shall be that of Tolerance Class 4h6h.
11. THREAD GAGING. Acceptability of screw threads shall be determined based on System 22 of ANSI/ASME B1.3M.
12. POINT CHAMFER. The point shall be flat or slightly concave and chamfered. The chamfer shall extend slightly below the root of the thread, and the edge between the flat and chamfer may be slightly rounded. The included angle of the point shall be approximately 90°. Chamfering on screw sizes up to and including mm and of larger screws with lengths shorter than 0.75 times the basic screw diameter shall be optional.
13. FILLET. For all lengths of screws, the form of the fillet at the junction of head and shank shall be optional within the following provisions: The fillet shall be a smooth and continuous concave curve fairing into the bearing surface within the limits of diameter BV, with a junction radius of not less than F, and blending into the shank at a distance from the head not exceeding E, as determined at the basic screw diameter D.
14. TOTAL RUNOUT. The total runout between the head body and thread on socket cap screws shall be such that the screw will assembly into a compound hole (see Table 38), that is threaded at one end to the basic thread size (class 6H min.) for a depth equivalent to 1.5 times the basic screw diameter and counterbored at the other end of diameter AE and through the center portion to diameter DE as specified in Table 38. These diameters shall be concentric with the axis of the thread within the equivalent of 10% of the thread pitch diameter tolerance. The starting thread shall be chamfered and the juncture of the corners shall be chamfered or rounded to a diameter equal to B maximum.

Applicable Standards and Specifications
ASME/ANSI B18.3.1M and ASTM A574M

TABLE 37 HOLO-KROME METRIC SOCKET HEAD CAP SCREWS

GRIP LENGTH — L_G . The maximum distance from the bearing surface of the head to the first completed for full form thread. A clamped part thinner than L_G would not allow the screw to seat.

BODY LENGTH — L_B . The minimum length of the unthreaded cylindrical portion of the shank.

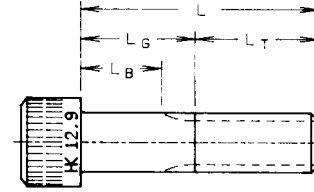

TABLE 37 BODY AND GRIP LENGTHS

NOMINAL SIZE	M1.6		M2		M2.5		M3		M4		M5		M6		M8		M10		M12		M14		M16		M20		M24	
	L_G	L_B	L_G	L_B	L_G	L_B	L_G	L_B	L_G	L_B	L_G	L_B	L_G	L_B	L_G	L_B	L_G	L_B	L_G	L_B	L_G	L_B	L_G	L_B	L_G	L_B	L_G	L_B
20	4.8	3.0	4.0	2.0																								
25	9.8	8.0	9.0	7.0																								
30	14.8	13.0	14.0	12.0	8.0	5.7	7.0	4.5																				
35	—	—	19.0	17.0	13.0	10.7	12.0	9.5	10.0	6.5																		
									15.0	11.5	13.0	9.0	11.0	6.0														
40	—	—	24.0	22.0	23.0	20.7	22.0	19.5	20.0	16.5	18.0	14.0	16.0	11.0														
45	—	—	—	—	28.0	25.7	27.0	24.5	25.0	21.5	23.0	19.0	21.0	16.0	17.0	10.7												
50	—	—	—	—	33.0	30.7	32.0	29.5	30.0	26.5	28.0	24.0	26.0	21.0	22.0	15.7	18.0	10.5										
55	—	—	—	—	—	—	37.0	34.5	35.0	31.5	33.0	29.0	31.0	26.0	27.0	20.7	23.0	15.5										
60	—	—	—	—	—	—	42.0	39.5	40.0	36.5	38.0	34.0	36.0	31.0	32.0	25.7	28.0	20.5	24.0	15.2								
65	—	—	—	—	—	—	47.0	44.5	45.0	41.5	43.0	39.0	41.0	36.0	37.0	30.7	33.0	25.5	29.0	20.2	25.0	15.0						
70	—	—	—	—	—	—	—	—	50.0	46.5	48.0	44.0	46.0	41.0	42.0	35.7	38.0	30.5	34.0	25.2	30.0	20.0	26.0	16.0				
80	—	—	—	—	—	—	—	—	60.0	56.5	58.0	54.0	56.0	51.0	52.0	45.7	48.0	40.5	44.0	35.2	40.0	30.0	36.0	26.0				
90	—	—	—	—	—	—	—	—	—	—	68.0	64.0	66.0	61.0	62.0	55.7	58.0	50.5	54.0	45.2	50.0	40.0	46.0	36.0	38.0	25.5		
100	—	—	—	—	—	—	—	—	—	—	78.0	74.0	76.0	71.0	72.0	65.7	68.0	60.5	64.0	55.2	60.0	50.0	56.0	46.0	48.0	35.5	40.0	25.0
110	—	—	—	—	—	—	—	—	—	—	—	—	86.0	81.0	82.0	75.7	78.0	70.5	74.0	65.2	70.0	60.0	66.0	56.0	58.0	45.5	50.0	35.0
120	—	—	—	—	—	—	—	—	—	—	—	—	96.0	91.0	92.0	85.7	88.0	80.5	84.0	75.2	80.0	70.0	76.0	66.0	68.0	55.5	60.0	45.0
130	—	—	—	—	—	—	—	—	—	—	—	—	—	—	102.0	95.7	98.0	90.5	94.0	85.2	90.0	80.0	86.0	76.0	78.0	65.5	70.0	55.0
140	—	—	—	—	—	—	—	—	—	—	—	—	—	—	112.0	105.7	108.0	100.5	104.0	95.2	100.0	90.0	96.0	86.0	88.0	75.5	80.0	65.0
150	—	—	—	—	—	—	—	—	—	—	—	—	—	—	122.0	115.7	118.0	110.5	114.0	105.2	110.0	100.0	106.0	96.0	98.0	85.5	90.0	75.0
160	—	—	—	—	—	—	—	—	—	—	—	—	—	—	132.0	125.7	128.0	120.5	124.0	115.2	120.0	110.0	116.0	106.0	108.0	95.5	100.0	85.0
180	—	—	—	—	—	—	—	—	—	—	—	—	—	—	—	—	148.0	140.5	144.0	135.2	140.0	130.0	126.0	136.0	128.0	115.5	120.0	105.0
200	—	—	—	—	—	—	—	—	—	—	—	—	—	—	—	—	168.0	160.5	164.0	155.2	160.0	150.0	146.0	156.0	148.0	135.5	140.0	125.0
220	—	—	—	—	—	—	—	—	—	—	—	—	—	—	—	—	—	—	184.0	175.2	180.0	170.0	166.0	176.0	168.0	155.5	160.0	145.0
240	—	—	—	—	—	—	—	—	—	—	—	—	—	—	—	—	—	—	204.0	195.2	200.0	190.0	186.0	196.0	188.0	175.5	180.0	165.0
260	—	—	—	—	—	—	—	—	—	—	—	—	—	—	—	—	—	—	—	—	220.0	210.0	206.0	216.0	208.0	195.5	200.0	185.0
300	—	—	—	—	—	—	—	—	—	—	—	—	—	—	—	—	—	—	—	—	—	—	246.0	256.0	248.0	235.5	240.0	225.0

NOTES FOR TABLE 37

1. Screws of diameter/length combinations above heavy line shall be threaded full length.
2. For screw sizes and/or lengths not tabulated, see Note 2, Table 36.

TABLE 38 HOLO-KROME METRIC SOCKET HEAD CAP SCREWS

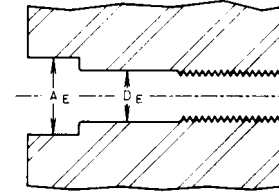

TABLE 38 FUNCTIONAL LIMITS FOR RUNOUT OF HEAD, BODY, AND THREAD ON METRIC SOCKET HEAD CAP SCREWS

NOMINAL SIZE		M1.6	M2	M2.5	M3	M4	M5	M6	M8	M10	M12											
NOMINAL LENGTH		HOLE DIAMETERS FOR SHANK D _E AND FOR HEAD A _E																				
OVER	TO. INCL.	D _E	A _E	D _E	A _E	D _E	A _E	D _E	A _E	D _E	A _E	D _E	A _E	D _E	A _E	D _E	A _E	D _E	A _E	D _E	A _E	
0	6	1.66	3.21	2.05	4.00	—	—	—	—	—	—	—	—	—	—	—	—	—	—	—	—	—
6	12	1.72	3.27	2.11	4.06	—	—	—	—	—	—	—	—	—	—	—	—	—	—	—	—	—
12	20	1.80	3.35	2.18	4.13	—	—	—	—	—	—	—	—	—	—	—	—	—	—	—	—	—
20	25	1.85	3.40	2.22	4.17	—	—	—	—	—	—	—	—	—	—	—	—	—	—	—	—	—
25	35	—	—	2.31	4.26	—	—	—	—	—	—	—	—	—	—	—	—	—	—	—	—	—
0	12	—	—	—	—	2.60	4.75	3.09	5.74	—	—	—	—	—	—	—	—	—	—	—	—	—
12	25	—	—	—	—	2.70	4.85	3.18	5.83	—	—	—	—	—	—	—	—	—	—	—	—	—
25	35	—	—	—	—	2.78	4.93	3.25	5.90	—	—	—	—	—	—	—	—	—	—	—	—	—
35	50	—	—	—	—	2.90	5.05	3.36	6.01	—	—	—	—	—	—	—	—	—	—	—	—	—
50	60	—	—	—	—	—	—	3.44	6.09	—	—	—	—	—	—	—	—	—	—	—	—	—
0	20	—	—	—	—	—	—	—	—	4.13	7.28	5.12	8.77	—	—	—	—	—	—	—	—	—
20	35	—	—	—	—	—	—	—	—	4.22	7.37	5.20	8.85	—	—	—	—	—	—	—	—	—
35	60	—	—	—	—	—	—	—	—	4.38	7.53	5.34	8.99	—	—	—	—	—	—	—	—	—
60	70	—	—	—	—	—	—	—	—	4.44	7.59	5.39	9.04	—	—	—	—	—	—	—	—	—
70	100	—	—	—	—	—	—	—	—	4.63	7.78	5.56	9.21	—	—	—	—	—	—	—	—	—
0	25	—	—	—	—	—	—	—	—	—	—	—	—	6.13	10.18	8.11	13.27	10.10	16.30	12.09	18.33	—
25	50	—	—	—	—	—	—	—	—	—	—	—	—	6.26	10.41	8.22	13.38	10.20	16.40	12.18	18.42	—
50	70	—	—	—	—	—	—	—	—	—	—	—	—	6.36	10.51	8.31	13.47	10.28	16.48	12.25	18.49	—
70	100	—	—	—	—	—	—	—	—	—	—	—	—	6.51	10.66	8.44	13.60	10.40	16.60	12.36	18.60	—
100	150	—	—	—	—	—	—	—	—	—	—	—	—	6.64	10.79	8.64	13.80	10.60	16.80	12.54	18.78	—

NOMINAL SIZE		M14	M16	M20	M24	M30	M36	M42	M48													
NOMINAL LENGTH		HOLE DIAMETERS FOR SHANK D _E AND FOR HEAD A _E																				
OVER	TO. INCL.	D _E	A _E	D _E	A _E	D _E	A _E	D _E	A _E	D _E	A _E	D _E	A _E	D _E	A _E	D _E	A _E	D _E	A _E			
0	50	14.17	21.45	16.16	24.48	20.14	30.54	24.13	36.61	—	—	—	—	—	—	—	—	—	—	—	—	—
50	100	14.34	21.62	16.32	24.64	20.28	30.68	24.26	36.74	—	—	—	—	—	—	—	—	—	—	—	—	—
100	150	14.50	21.78	16.47	24.79	20.42	30.82	24.38	36.86	—	—	—	—	—	—	—	—	—	—	—	—	—
150	200	14.64	21.92	16.63	24.95	20.56	30.96	24.51	36.99	—	—	—	—	—	—	—	—	—	—	—	—	—
200	250	14.64	21.92	16.64	24.96	20.64	31.04	24.64	37.12	—	—	—	—	—	—	—	—	—	—	—	—	—
0	150	—	—	—	—	—	—	—	—	30.38	45.98	36.38	55.10	42.38	64.22	48.38	73.34	—	—	—	—	—
150	300	—	—	—	—	—	—	—	—	30.75	46.35	36.75	55.47	42.75	64.59	48.75	73.71	—	—	—	—	—
300	450	—	—	—	—	—	—	—	—	31.12	46.72	37.12	55.84	43.12	64.96	49.12	74.08	—	—	—	—	—
450	600	—	—	—	—	—	—	—	—	31.50	47.10	37.50	56.22	43.50	65.34	49.50	74.46	—	—	—	—	—

TABLE 39 HOLO-KROME METRIC SOCKET HEAD CAP SCREWS

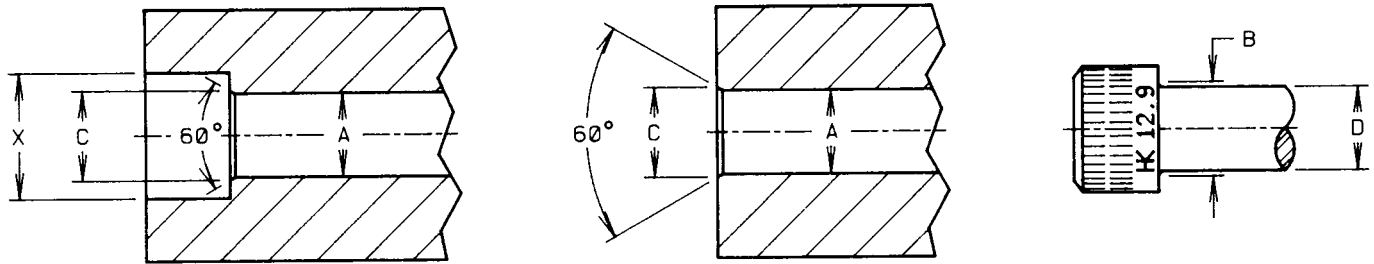

TABLE 39 DRILL AND COUNTERBORE SIZES - METRIC SERIES

NOMINAL SIZE	A		X COUNTERBORE DIAMETER	C COUNTERSINK DIAMETER [NOTE (1)]
	NOMINAL DRILL SIZE			
	CLOSE FIT [NOTE (2)]	NORMAL FIT [NOTE (3)]		
M1.6	1.80	1.95	3.50	2.0
M2	2.20	2.40	4.40	2.6
M2.5	2.70	3.00	5.40	3.1
M3	3.40	3.70	6.50	3.6
M4	4.40	4.80	8.25	4.7
M5	5.40	5.80	9.75	5.7
M6	6.40	6.80	11.25	6.8
M8	8.40	8.80	14.25	9.2
M10	10.50	10.80	17.25	11.2
M12	12.50	12.80	19.25	14.2
M14	14.50	14.75	22.25	16.2
M16	16.50	16.75	25.50	18.2
M20	20.50	20.75	31.50	22.4
M24	24.50	24.75	37.50	26.4
M30	30.75	31.75	47.50	33.4
M36	37.00	37.50	56.50	39.4

NOTES FOR TABLE 36

1. COUNTERSINK. It is considered good practice to countersink or break the edges of holes that are smaller than B maximum in parts having a hardness that approaches, equals, or exceeds the screw hardness. If such holes are not countersunk, the heads of screws may not seat properly or the sharp edges on the hole may deform the fillets on screws, thereby making them susceptible to fatigue in applications involving dynamic loading. The countersink or corner relief, however, should not be larger than is necessary to insure that the fillet on the screw is cleared. Normally, the diameter of countersink does not have to exceed B maximum.

Countersinks or corner reliefs in excess of this diameter reduce the effective bearing area and introduce the possibility of imbedment where the parts to be fastened are softer than the screws, or of brinelling or flaring the heads of the screws where the parts to be fastened are harder than the screws.

2. CLOSE FIT. The close fit is normally limited to holes for those lengths of screws that are threaded to the head (see Table 38) in assemblies where only one screw is to be used or where two or more screws are to be used and the mating holes are to be produced either at assembly or by matched and coordinated tooling.

3. NORMAL FIT. The normal fit is intended for screws of relatively long length or for assemblies involving two or more screws of relatively long length or for assemblies involving two or more screws where the mating holes are to be produced by conventional tolerancing methods. It provides for the maximum allowable eccentricity of the longest standard screws and for certain variations in the parts to be fastened, such as: deviations in hole straightness, angularity between the axis of the tapped hole and that of the hole for shank, differences in center distances of the mating holes, etc.

TABLE 40 HOLO-KROME METRIC HEXAGON SOCKET BUTTON HEAD CAP SCREWS

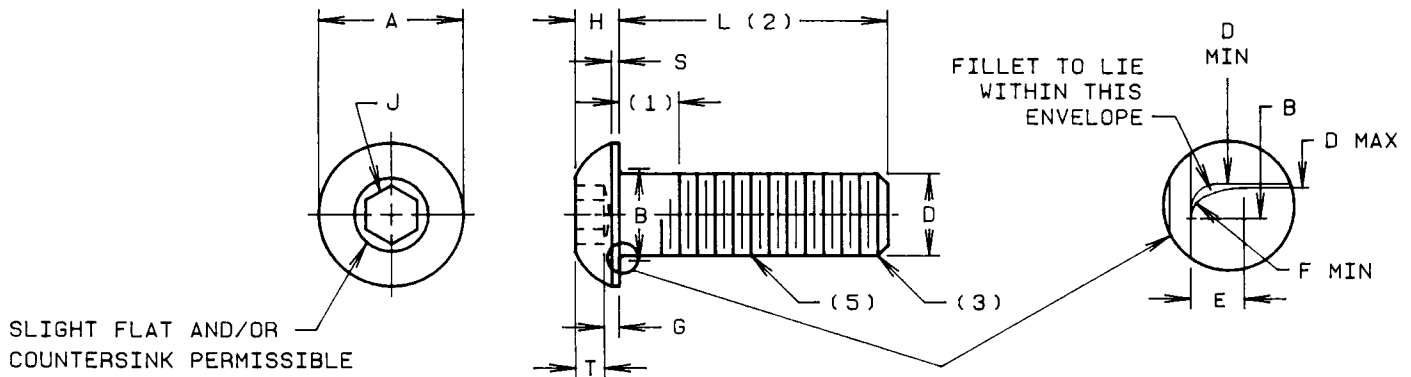

TABLE 40 DIMENSIONS

D	A		H		S	J	T	G	B		E	R	L
	HEAD DIAMETER		HEAD HEIGHT		HEAD SIDE HEIGHT	HEXAGON SOCKET SIZE	KEY ENGAGEMENT	WALL THICKNESS	TRANSITION DIAMETER		TRANSITION LENGTH	JUNCTURE RADIUS	MAXIMUM STANDARD LENGTH
	MAX.	MIN.	MAX.	MIN.	REF.	NOM.	MIN.	MIN.	MAX.	MIN.	MAX.	MIN.	NOM.
M3 x 0.5	5.70	5.40	1.65	1.43	0.38	2	1.04	0.20	3.6	3.2	0.51	0.10	12
M4 x 0.7	7.60	7.24	2.20	1.95	0.38	2.5	1.30	0.30	4.7	4.4	0.60	0.20	20
M5 x 0.8	9.50	9.14	2.75	2.50	0.50	3	1.56	0.38	5.7	5.4	0.60	0.20	30
M6 x 1	10.50	10.07	3.30	3.00	0.80	4	2.08	0.74	6.8	6.5	0.68	0.25	30
M8 x 1.25	14.00	13.57	4.40	4.05	0.80	5	2.60	1.05	9.2	8.8	1.02	0.40	40
M10 x 1.5	17.50	17.07	5.50	5.20	0.80	6	3.12	1.45	11.2	10.8	1.02	0.40	40
M12 x 1.75	21.00	20.48	6.60	6.24	0.80	8	4.16	1.63	14.2	13.2	1.87	0.60	60
M16 x 2	28.00	27.48	8.80	8.44	1.50	10	5.20	2.25	18.2	17.2	1.87	0.60	60

NOTES FOR TABLE 40

- 1. THREAD LENGTH.** Screws of nominal lengths equal to or shorter than the length listed in column L shall be threaded full length. The distance measured parallel to the axis of the screw from the underside of the head to the face of a non-countersunk standard GO ring gage assembled by hand as far as the thread will permit, shall not exceed two pitches.
- 2. LENGTH.** The length of the screw (L) shall be measured parallel to the axis of the screw from the plane of the bearing surface under the head to the plane of the flat of the point.
- 3. POINT.** The points of button head cap screws shall be chamfered, with the chamfer extending slightly below the root of the thread and the edge between the flat and the chamfer may be slightly rounded. The included angle of the point shall be approximately 90°. Chamfering on screw sizes up to the including 4mm in diameter and of larger sizes with the length shorter than 0.75 times the basic screw diameter, shall be optional..

- 4. SOCKET TRUE POSITION.** The axis of the socket shall be located at true position relative to the axis of the screw within a tolerance zone having a diameter equal to 3% of the basic screw diameter or 0.26mm, whichever is greater, for nominal screw sizes up to 12mm, and equal to 6% of the basic screw diameter for sizes larger than 12mm, regardless of feature size.
- 5. THREADS AND GAGING.** Threads shall be metric coarse series, in accordance with ANSI/ASME B1.13M, Metric Screw Threads, -M Profile. Acceptability of screw threads shall be determined based on System 22 of ANSI/ASME B1.3M.
- 6. THREAD TOLERANCE CLASS.** Threads shall be Tolerance Class 4g6g. For plated screws the allowance g may be consumed by the plating so that the maximum limit of size after plating shall be 4h6h.

Applicable Standards and Specifications
ASME/ANSI B18.3.4M and ASTM F835M

TABLE 41 HOLO-KROME METRIC FLAT COUNTERSUNK SOCKET HEAD CAP SCREWS

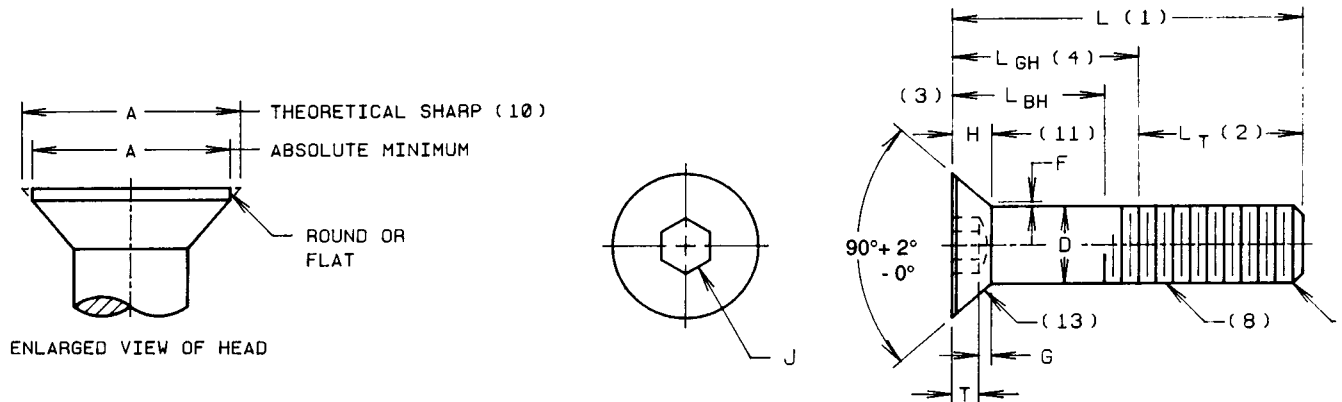

TABLE 41 DIMENSIONS

NOMINAL SIZE AND THREAD PITCH	D		A		H		J	T	G	F
	BODY DIAMETER		HEAD DIAMETER		HEAD HEIGHT					
	MAX.	MIN.	THEORETICAL SHARP MAX.	ABSOLUTE MIN.	REFERENCE	FLUSHNESS TOLERANCE				
M3 x 0.5	3.0	2.86	6.72	5.35	1.86	0.25	2.0	1.1	0.31	0.25
M4 x 0.7	4.0	3.82	8.96	7.80	2.48	0.25	2.5	1.5	0.45	0.35
M5 x 0.8	5.0	4.82	11.20	9.75	3.10	0.30	3.0	1.8	0.66	0.40
M6 x 1	6.0	5.82	13.44	11.70	3.72	0.35	4.0	2.4	0.70	0.50
M8 x 1.25	8.0	7.78	17.92	15.60	4.96	0.40	5.0	3.0	1.16	0.60
M10 x 1.5	10.0	9.78	22.40	19.50	6.20	0.40	6.0	3.6	1.62	0.80
M12 x 1.75	12.0	11.73	26.88	23.40	7.44	0.45	8.0	4.6	1.80	0.90
M14* x 2	14.0	13.73	30.80	26.52	8.40	0.50	10.0	5.5	1.80	1.00
M16 x 2	16.0	15.73	33.60	29.01	8.80	0.50	10.0	5.5	2.20	1.00
M20 x 2.5	20.0	19.67	42.00	36.05	11.00	0.75	12.0	7.2	2.20	1.20

NOTE *Not recommended for new design.

NOTES FOR TABLE 41

- LENGTH L.** The length of hexagon socket flat countersunk screws is measured on a line parallel to the axis, from the plane of top of the head to the plane of the flat of the point.
- THREAD LENGTH.** The length of the screw is the distance from the extreme point to the last complete or full form thread. It is controlled by the grip length, L_{GH} as defined below. See Table 42 for grip and body lengths of standard screws.
- BODY L_{BH} .** The unthreaded cylindrical portion of the shank for screws that are not threaded to the head. This represents the minimum length of full body plus the reference head height.
- GRIP LENGTH L_{GH} .** The maximum length representing the design grip length of the screw. It is measured from the top of the head, parallel to the axis of the screw, to the face of a GO thread ring gage with the countersink and/or counterbore removed. See Table 42 for grip and body lengths.
- POINT** The points of flat countersunk cap screws shall be chamfered, with the chamfer extending slightly below the root of the thread and the edge between the flat and the chamfer may be slightly rounded. The included angle of the point shall be approximately 90°. Chamfering on screw sizes up to and including 4mm in diameter and of larger sizes with the length shorter than 0.75 times the basic screw diameter, shall be optional.
- SOCKET TRUE POSITION.** The axis of the socket shall be located at true position relative to the axis of the screw within a tolerance zone having a diameter equal to 3% of the basic screw diameter or 0.26mm, whichever is greater, for nominal screw sizes up to 12mm, and equal to 6% of the basic screw diameter for sizes larger than 12mm, regardless of feature size.

- CONCENTRICITY.** Concentricity of the thread with the body shall be within 0.13mm per mm of body length (unthreaded portion) full (total) indicator reading, taken directly under the head when the screw is held by the full threads closest to the head of the screw and shall not exceed 0.64mm.
- THREADS AND GAGING.** Threads shall be metric coarse series, in accordance with ANSI/ASME B1.13M, Metric Screw Threads, -M Profile. Acceptability of screw threads to be determined based on System 22 of ANSI/ASME B1.3M.
- THREAD TOLERANCE CLASS** Threads shall be Tolerance Class 4g6g. For plated screws the allowance g may be consumed by the plating so that the maximum limit of size after plating shall be 4h6h.
- HEAD DIAMETERS.** The maximum sharp values listed under A in Table 41 are theoretical values, as it is not practical to make the edges of the head sharp. The maximum sharp value represents the exact diameter of the hole countersunk to exactly 90° in which a screw having maximum head size will it flush.
- HEAD HEIGHT (H).** The tabulated values for head height are given for reference only and are calculated to the maximum formulation.
- FLUSHNESS TOLERANCE.** The flushness tolerance is the distance the top surface of the screw having the minimum head size will be below the flush condition in the hole countersunk exactly 90° to the maximum sharp dimension listed under A in Table 41.
- BEARING SURFACE.** The axis of the conical bearing surface shall be parallel to the axis of the body with 1/2°.

Applicable Standards and Specifications
ASME/ANSI B18.3.5M and ASTM F 835M

TABLE 42 BODY AND GRIP LENGTHS

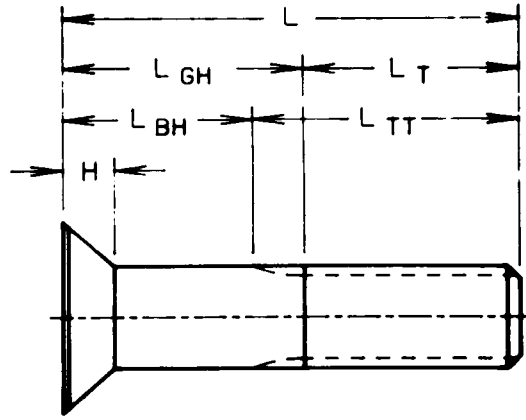

HEXAGON SOCKET FLAT COUNTERSUNK HEAD CAP SCREWS (METRIC SERIES)

NOMINAL DIAMETER	M3		M4		M5		M6		M8		M10		M12		M14		M16		M20		
NOMINAL LENGTH	L _{GH}	L _{BH}	L _{GH}	L _{BH}	L _{GH}	L _{BH}	L _{GH}	L _{BH}	L _{GH}	L _{BH}	L _{GH}	L _{BH}	L _{GH}	L _{BH}	L _{GH}	L _{BH}	L _{GH}	L _{BH}	L _{GH}	L _{BH}	
35	17	14.5	15	11.5																	
40	22	19.5	20	16.5	18	14															
45	27	24.5	25	21.5	23	19	21	16													
50	32	29.5	30	26.5	28	24	26	21	22	15.7											
55	37	34.5	35	31.5	33	29	31	26	27	20.7											
60			40	36.5	38	34	36	31	32	25.7	28	20.5									
65			45	41.5	43	39	41	36	37	30.7	33	25.5	29	20.2							
70			50	46.5	48	44	46	41	42	35.7	38	30.5	34	25.2	30	20					
80			60	56.5	58	54	56	51	52	45.7	48	40.5	44	35.2	40	30	36	26			
90					68	64	66	61	62	55.7	58	50.5	54	45.2	50	40	46	36			
100					78	74	76	71	72	65.7	68	60.5	64	55.2	60	50	56	46			
110							86	81	82	75.7	78	70.5	74	65.2	70	60	66	56	58	45.5	
120							96	91	92	85.7	88	80.5	84	75.2	80	70	76	66	68	55.5	
130									102	95.7	98	90.5	94	85.2	90	80	86	76	78	65.5	
140									112	105.7	108	100.5	104	95.2	100	90	96	86	88	75.5	
150									122	115.7	118	110.5	114	105.2	110	100	106	96	98	85.5	

TABLE 42A THREAD LENGTHS FOR LENGTHS NOT TABULATED IN TABLE 42

D NOMINAL SCREW DIAMETER	L _T MINIMUM THREAD LENGTH	L _{TT} MAXIMUM TOTAL THREAD LENGTH
M3	18.0	20.5
M4	20.0	23.5
M5	22.0	26.0
M6	24.0	29.0
M8	28.0	34.3
M10	32.0	39.5
M12	36.0	44.8
M14	40.0	50.0
M16	44.0	54.0
M20	52.0	64.5

TABLE 43 HOLO-KROME METRIC HEXAGON SOCKET HEAD SHOULDER SCREWS

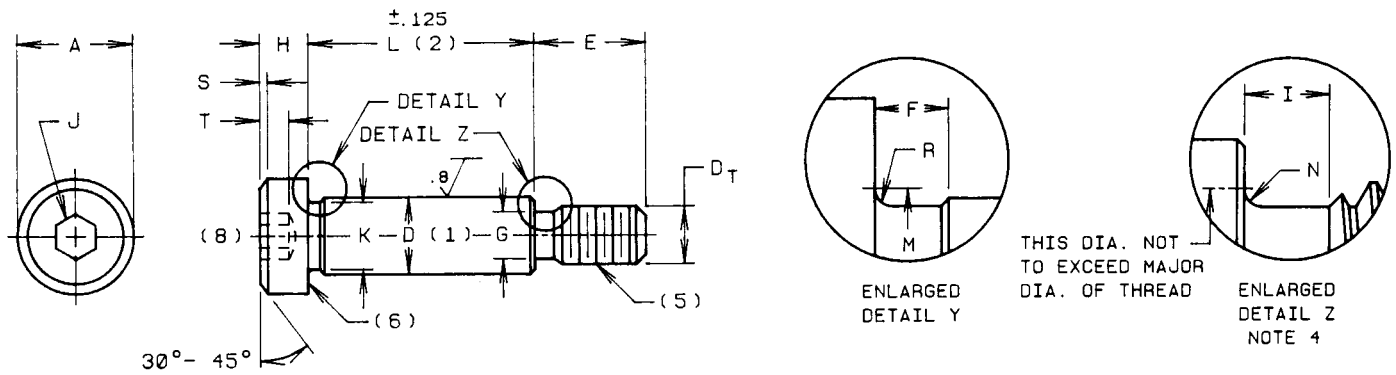

TABLE 43 DIMENSIONS OF METRIC HEXAGON SOCKET HEAD SHOULDER SCREWS

NOMINAL SCREWS SIZE OR BASIC SHOULDER DIAMETER	D		A		H		S	J	T	M	R
	SHOULDER DIAMETER		HEAD DIAMETER		HEAD HEIGHT		CHAMFER OR RADIUS	HEXAGON SOCKET SET	KEY ENGAGEMENT	HEAD FILLET EXTENSION DIAMETER	SHOULDER NECK FILLET RADIUS
	MAX.	MIN.	MAX.	MIN.	MAX.	MIN.	MAX.	MAX.	MAX.	MAX.	MAX.
6.0*	5.987	5.951								7.0	
6.5	6.487	6.451	10.00	9.78	4.50	4.32	0.6	3	2.4	7.5	0.2
8.0	7.987	7.951	13.00	12.73	5.50	5.32	0.8	4	3.3	9.2	0.4
10.0	9.987	9.951	16.00	15.73	7.00	6.78	1.0	5	4.2	11.2	0.4
12.0*	11.984	11.941								14.2	
13.0	12.984	12.941	18.00	17.73	9.00	8.78	1.2	6	4.9	15.2	0.6
16.0	15.984	15.941	24.00	23.67	11.00	10.73	1.6	8	6.6	18.2	0.6
20.0	19.980	19.928	30.00	29.67	14.00	13.73	2.0	10	8.8	22.4	0.8
24.0*	23.980	23.929								26.4	
25.0	24.980	24.928	36.00	35.61	16.00	15.73	2.4	12	10.0	27.4	0.8

TABLE 43 DIMENSIONS (Continued)

NOMINAL SCREWS SIZE OR BASIC SHOULDER DIAMETER	K	F	D _T		G		I	N		E
	SHOULDER NECK DIAMETER	SHOULDER NECK WIDTH	NORMAL THREAD SIZE OR BASIC THREAD DIAMETER	THREAD PITCH	THREAD NECK DIAMETER		THREAD NECK WIDTH	THREAD NECK FILLET RADIUS		THREAD LENGTH
	MIN.	MAX.			MAX.	MIN.	MAX.	MAX.	MIN.	MAX.
6.0*										
6.5	5.42									
8.0	5.92	2.5	5	0.8	3.86	3.68	2.4	0.66	0.50	9.75
10.0	7.42	2.5	6	1	4.58	4.40	2.6	0.69	0.53	11.25
	9.45	2.5	8	1.25	6.25	6.03	2.8	0.80	0.64	13.25
12.0*										
13.0	11.42									
16.0	12.42	2.5	10	1.5	7.91	7.69	3.0	0.93	0.77	16.40
20.0	15.42	2.5	12	1.75	9.57	9.35	4.0	1.03	0.87	18.40
	19.42	2.5	16	2	13.23	12.96	4.8	1.30	1.14	22.40
24.0*										
25.0	23.42									
	24.42	3.0	20	2.5	16.57	16.30	5.6	1.46	1.30	27.40

*These dimensions for product made prior to final standardization by USA and ISO.

NOTES FOR TABLE 43 (SHOULDER SCREWS)

1. **SHOULDER.** The shoulder is the enlarged unthreaded shank portion of the screw, the diameter of which serves as the basis for derivation of the nominal screw size. This diameter shall be ground to the limits for D specified in Table 43 and a surface roughness not exceeding 0.8 μm Ra.

2. **LENGTH.** The basic length of the socket head shoulder screw shall be the nominal length of the shoulder, expressed in millimeters, measured parallel to the axis of the screw, from the plane of the bearing surface of the head to the plane of the shoulder at the threaded end.

3. **STANDARD LENGTH.** The standard lengths for shoulder screws shall be as follows: 10, 12, 16, 20, 25, 30, 40, 50, 60, 70, 80, 90, 100, 110, and 120mm.

4. **THREAD NECK.** The neck portion between the thread and shoulder shall allow the face of the shoulder to seat against the face of a standard basic GO ring gage assembled onto the threaded end.

5. **THREADS AND GAGING.** Threads shall be the metric coarse series, in accordance with ANSI/ASME B1.13M, Metric Screw Threads, M Profile. Acceptability of screw threads shall be based on System 22 of ANSI/ASME B1.3M.

6. **THREAD TOLERANCE CLASS.** Threads shall be Tolerance Class 4g6g. For plated screws, the allowance g may be consumed by the thickness of the plating so that the maximum size limit after plating shall be that of Tolerance Class 4h6h.

7. **THREAD LENGTH TOLERANCE.** The tolerance on the length of threaded portion shall be minus 0.50mm for nominal screw sizes up to and including 10mm and 0.75mm for larger sizes.

8. **CONCENTRICITY.** The shoulder and thread pitch diameter shall be concentric with 0.10mm full indicator movement (FIM), determined at a distance of 4.75mm from the face of the shoulder.

Concentricity, parallelism, bow and squareness of the face of the shoulder with the axis of the thread shall be within 0.125mm FIM per 25.0mm of the shoulder length, with maximum of 0.7mm, when the shoulder face is firmly seated against a threaded bushing and deviation is checked on the shoulder at a distance of 2F from the underside of the head. The thread in the bushing shall be basic size, and the bushing outside diameter and ends shall be concentric and square with the axis of the thread, respectively.

Applicable Standards and Specifications

ASME/ANSI B18.3.3M

TABLE 44 HOLO-KROME METRIC SOCKET SET SCREWS

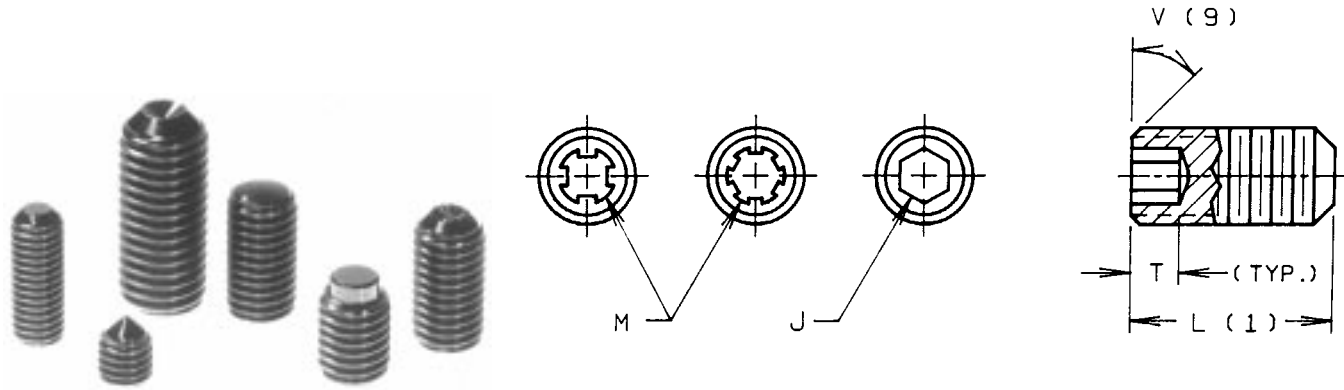
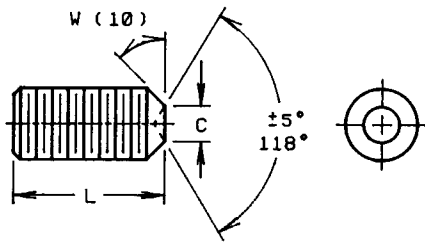
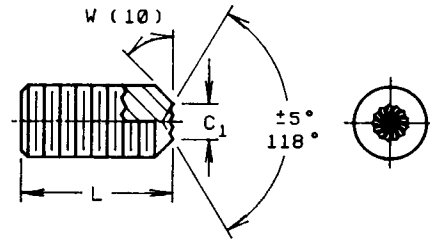

TABLE 44 DIMENSIONS OF METRIC SOCKET SET SCREWS

D	J	M	L	T						D	J	M	L	T					
				MINIMUM KEY ENGAGEMENT										MINIMUM KEY ENGAGEMENT					
				CUP AND FLAT POINTS		CONE AND OVAL POINTS		HALF DOG POINTS						CUP AND FLAT POINTS		CONE AND OVAL POINTS		HALF DOG POINTS	
				HEX T _H	SPL T _S	HEX T _H	SPL T _S	HEX T _H	SPL T _S					HEX T _H	SPL T _S	HEX T _H	SPL T _S	HEX T _H	SPL T _S
MIN.		MIN.		MIN.		MIN.		MIN.		MIN.		MIN.							
M1.6 x 0.35	0.7	0.84	1.5	0.6	0.6	0.6	0.6	-	-	M6 x 1	3	3.68	4	1.8	1.8	-	-	-	-
			2	0.8	0.7	0.8	0.7	0.6	0.6				5	2.5	2.5	1.8	1.8	1.5	1.5
			2.5	1.0	0.7	1.0	0.7	0.7	0.7				6	3.0	3.0	2.7	2.7	2.0	2.0
			3	1.25	0.7	1.25	0.7	1.25	0.7				8	3.0	3.0	3.0	3.0	3.0	3.0
M2 x 0.4	0.9	0.84	1.5	0.6	0.6	0.6	0.6	-	-	M8 x 1.25	4	4.65	5	1.8	1.8	-	-	-	-
			2	0.8	0.7	0.8	0.7	-	-				6	2.5	2.5	2.3	2.3	1.8	1.8
			2.5	1.0	0.7	1.0	0.7	0.8	0.7				8	4.0	4.0	3.5	3.5	3.0	3.0
			3	1.2	0.7	1.2	0.7	1.2	0.7				10	4.0	4.0	4.0	4.0	4.0	4.0
M2.5 x 0.45	1.3	1.22	2	0.7	0.7	0.7	0.7	-	-	M10 x 1.5	5	5.49	6	2.0	2.0	-	-	-	-
			2.5	1.1	1.0	1.1	1.0	0.9	0.9				8	3.6	3.6	3.0	3.0	2.5	2.5
			3	1.5	1.0	1.3	1.0	1.2	1.0				10	5.0	5.0	4.0	4.0	4.0	4.0
			4	1.8	1.0	1.8	1.0	1.8	1.0				12	5.0	5.0	5.0	5.0	5.0	5.0
M3 x 0.5	1.5	1.52	2	0.6	0.6	-	-	-	-	M12 x 1.75	6	6.38	8	3.0	3.0	-	-	-	-
			2.5	1.1	1.1	0.7	0.7	-	-				10	4.5	4.5	3.8	3.8	3.5	3.5
			3	1.5	1.2	1.0	1.0	1.0	1.0				12	6.0	6.0	5.0	5.0	5.0	5.0
			4	2.1	1.2	1.5	1.2	2.0	1.2				16	6.0	6.0	6.0	6.0	6.0	6.0
M4 x 0.7	2	2.44	2.5	1.0	1.0	-	-	-	-	M16 x 2	8	9.45	10	3.0	3.0	-	-	-	-
			3	1.3	1.3	1.0	1.0	1.0	1.0				12	4.8	4.8	3.0	3.0	3.0	3.0
			4	1.8	1.8	1.5	1.5	1.5	1.5				16	8.0	8.0	6.0	6.0	6.0	6.0
			5	2.3	2.0	2.0	2.0	2.0	2.0				20	8.0	8.0	8.0	8.0	8.0	8.0
M5 x 0.8	2.5	2.82	2.5	2.3	2.0	2.3	2.0	2.3	2.0	M20 x 2.5	10	11.53	12	-	-	-	-	-	-
			3	1.2	1.2	-	-	-	-				16	6.0	6.0	5.0	5.0	5.0	5.0
			4	2.0	2.0	1.2	1.2	-	-				20	9.0	9.0	8.0	8.0	8.0	8.0
			5	2.7	2.3	1.7	1.7	2.0	2.0				25	10.0	10.0	10.0	10.0	10.0	10.0
M5 x 0.8	2.5	2.82	3	1.2	1.2	-	-	-	-	M24 x 3	12	15.11	16'	5.0	5.0	-	-	-	-
			4	2.0	2.0	1.2	1.2	-	-				20	8.0	8.0	7.0	7.0	6.0	6.0
			5	2.7	2.3	1.7	1.7	2.0	2.0				25	12.0	12.0	10.0	10.0	10.0	10.0
			6	2.7	2.3	2.0	2.0	2.5	2.3				30	12.0	12.0	12.0	12.0	12.0	12.0



CUP POINT



HOLO-KNURL POINT

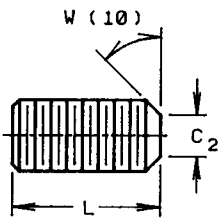

FLAT POINT

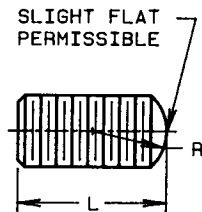

OVAL POINT

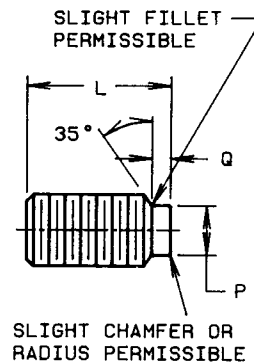

HALF DOG POINT

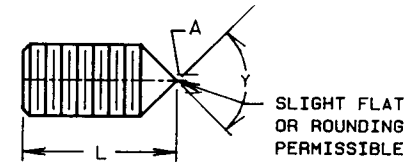

CONE POINT

TABLE 45 DIMENSIONS OF METRIC SOCKET SET SCREW POINTS

NOMINAL SIZE	C		C ₁		C ₂		R		Y	A		P				Q	
	CUP POINT DIAMETER		CUP POINT DIAMETER FOR HOLO-KNURL POINT		FLAT POINT DIAMETER		OVAL POINT RADIUS		CONE POINT ANGLE 90° FOR THESE LENGTHS AND OVER/118° FOR SHORTER LENGTHS	FLAT OR TRUNCATION ON CONE POINT		HALF DOG POINT					
	MAX.	MIN.	MAX.	MIN.	MAX.	MIN.	MAX.	MIN.		MAX.	MIN.	MAX.	MIN.	MAX.	MIN.	MAX.	MIN.
M1.6	0.80	0.55	0.80	0.64	0.80	0.55	1.60	1.20	3	0.16	0	0.80	0.55	0.53	0.40		
M2	1.00	0.75	1.00	0.82	1.00	0.75	1.90	1.50	3	0.20	0	1.00	0.75	0.64	0.50		
M2.5	1.25	1.05	1.25	1.05	1.50	1.25	2.28	1.88	4	0.25	0	1.50	1.25	0.78	0.63		
M3	1.50	1.28	1.50	1.28	2.00	1.75	2.65	2.25	4	0.30	0	2.00	1.75	0.92	0.75		
M4	2.00	1.75	2.00	1.75	2.50	2.25	3.80	3.00	5	0.40	0	2.50	2.25	1.20	1.00		
M5	2.50	2.22	2.50	2.22	3.50	3.20	4.55	3.75	6	0.50	0	3.50	3.20	1.37	1.25		
M6	3.00	2.75	3.00	2.69	4.00	3.70	5.30	4.50	8	1.50	1.2	4.00	3.70	1.74	1.50		
M8	4.00	3.65	4.00	3.65	5.50	5.20	6.80	6.00	10	2.00	1.6	5.50	5.20	2.28	2.00		
M10	5.00	4.60	5.00	4.60	7.00	6.64	8.30	7.50	12	2.50	2.0	7.00	6.64	2.82	2.50		
M12	6.00	5.57	6.00	5.57	8.50	8.14	9.80	9.00	16	3.00	2.4	8.50	8.14	3.35	3.00		
M16	8.00	7.50	8.00	7.50	12.00	11.57	12.80	12.00	20	4.00	3.2	12.00	11.57	4.40	4.00		
M20	10.00	9.44	10.00	9.44	15.00	14.57	15.80	15.00	25	5.00	4.0	15.00	14.57	5.45	5.00		
M24	12.00	11.39	12.00	11.39	18.00	17.57	18.80	18.00	30	6.00	4.8	18.00	17.57	6.49	6.00		

NOTES FOR TABLE 44 and 45

1. **LENGTH.** The length of the screw shall be measured overall, parallel to the axis of the screws.
2. **TOLERANCE ON LENGTH.** The tolerance on the screw length shall be:

Nominal Screw Length, mm	Length Tolerance, mm
Up to 12, incl.	± 0.3
Over 12 to 50, incl.	± 0.5
Over 50	± 0.8

3. **STANDARD LENGTHS.** The standard nominal screw lengths are 1.5, 2, 2.5, 3, 4, 5, 6, 8, 10, 12, 16, 20, 25, 30, 35, 40, 45, 50, 55, 60, 70, 80, 90, and 100mm. The minimum practical screw length for the respective screw sizes and point styles is represented by the shortest lengths listed in Table 44 for which T values are shown.

4. **THREADS AND GAGING.** Threads shall be the metric coarse series, in accordance with ANSI/ASME B1.3M.

As standard gages provide only for engagement lengths up to the equivalent of 1.5 times the thread diameter, changes in pitch diameter of either or both external and internal thread may be required to longer lengths of engagement.

5. **THREAD TOLERANCE CLASS.** Threads shall be Tolerance Class 4g6g. For plated screws, the allowance g may be consumed by the thickness of the plating so that the maximum size limit after plating shall be that of Tolerance Class 4h6h.

6. **KEY ENGAGEMENT.** For screws of nominal lengths exceeding those in Table 44, the minimum key engagement T for the longest length shown shall apply. This represents the minimum key engagement necessary to develop the full functional capability of the keys conforming to ANSI B18.3.2M, Metric series Hexagon Keys and Bits.

7. **SOCKET GAGING.** Acceptability of hexagon sockets shall be determined by the use of hexagon socket gages specified in ASME/ANSI B18.3.6M. The hexagon sockets shall allow the GO members of the gage to enter freely to the minimum engagement depth. The NOT GO members shall be permitted to enter only to a depth of 10% of the nominal size for sockets up to and including 1.5mm, and 7.5% of the nominal socket size for larger sizes. Acceptability of spline sockets shall be determined in similar fashion, using the spline gages specified in ASME/ANSI B18.3.6M.

8. **SOCKET TRUE POSITION.** The axis of the socket shall be located at true position relative to the axis of the screw within a tolerance zone having a diameter of 0.25mm, regardless of feature size.

9. **FACE CHAMFER.** The face on screws having a nominal length longer than the screw diameter shall be chamfered. The chamfer angle V shall be between 30° and 45°. The chamfer shall extend below the root of the thread, and the edge between the face and the chamfer may be slightly rounded. For screws having a nominal length equal to or shorter than the nominal diameter, chamfering shall be at the option of the manufacturer.

10. **POINT ANGLE.** The point angles specified shall apply only to those portions of the angles that lie below the root of the thread. The point angle W for flat and cup points shall be 45° +5°, -0°, for screws of length equal to the nominal screw diameter and longer, and 30° minimum for shorter screws.

11. **OTHER POINTS.** For other point configurations, see ASME/ANSI B18.3.6M

Applicable Standards and Specifications

ASME/ANSI B18.3.6M and ASTM F 912M.

TABLE 46 and 47 METRIC HEXAGON AND SPLINE SOCKETS

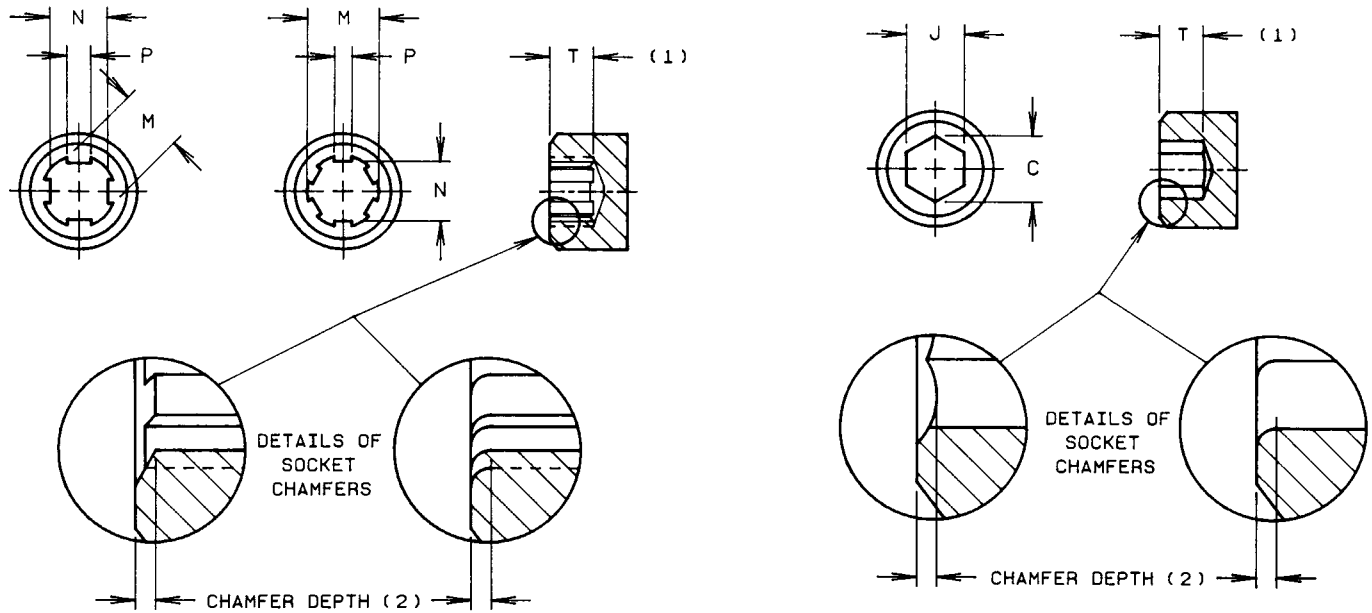

TABLE 46 DIMENSIONS OF METRIC SPLINE SOCKETS

NOMINAL SPLINE SOCKET SIZE	NUMBER OF TEETH	M		N		P	
		SOCKET MAJOR DIAMETER		SOCKET MINOR DIAMETER		WIDTH OF TOOTH	
		MAX.	MIN.	MAX.	MIN.	MAX.	MIN.
0.84	4	0.889	0.864	0.660	0.648	0.305	0.292
1.22	6	1.270	1.245	1.041	1.016	0.379	0.254
1.52	6	1.575	1.549	1.295	1.270	0.356	0.330
2.44	6	2.489	2.464	2.083	2.032	0.559	0.533
2.82	6	2.921	2.870	2.489	2.438	0.635	0.584
3.68	6	3.785	3.734	3.251	3.200	0.813	0.762
4.65	6	4.775	4.724	4.140	4.089	0.991	0.940
5.49	6	5.613	5.563	4.826	4.775	1.270	1.219
6.38	6	6.502	6.452	5.613	5.563	1.524	1.473
98.45	6	9.652	9.576	8.103	8.026	2.337	2.261
11.53	6	11.760	11.684	8.804	9.728	2.845	2.769
15.11	6	15.342	15.265	12.929	12.852	3.505	3.404

NOTES FOR TABLE 46

1. The tabulated dimensions represent direct soft metric conversions of the equivalent inch size spline sockets shown in Table 11. Therefore, the spline keys and bits shown in Table 49 are applicable for wrenching the corresponding size metric spline sockets.
2. Where spline sockets are chamfered, the depth of chamfer shall not exceed 10% of the nominal socket size for sizes up to and including 1.52 and 7.5% for larger sizes. For chamfered sockets, it is permissible for the NOT GO socket gage to enter to the depth of chamfer.

NOTES FOR TABLES 46 AND 47

1. SOCKET DEPTH (T). Applicable socket depths are specified in the dimensional tables and notes for the respective screw types.
2. SOCKET CHAMFER. Where sockets are chamfered, the depth of chamfer shall not exceed 10% of the nominal socket size, up to and including 1.5mm, and 7.5% for larger sizes. This is determined by measuring the depth of penetration of a NOT GO socket gage.

TABLE 47 DIMENSIONS OF METRIC HEXAGON SOCKETS

NOMINAL SOCKET SIZE	J		C
	DIMENSIONS ACROSS FLATS		
	MAX.	MIN.	DIMENSIONS ACROSS CORNERS
0.7	0.724	0.711	0.803
0.9	0.902	0.889	1.003
1.3	1.295	1.270	1.427
1.5	1.545	1.520	1.730
2	2.045	2.020	2.300
2.5	2.560	2.520	2.870
3	3.071	3.020	3.440
4	4.084	4.020	4.580
5	5.084	5.020	5.720
6	6.095	6.020	6.860
8	8.115	8.025	9.150
10	10.127	10.025	11.500
12	12.146	12.032	13.800

TABLE 48 METRIC ALLEN WRENCHES AND BITS

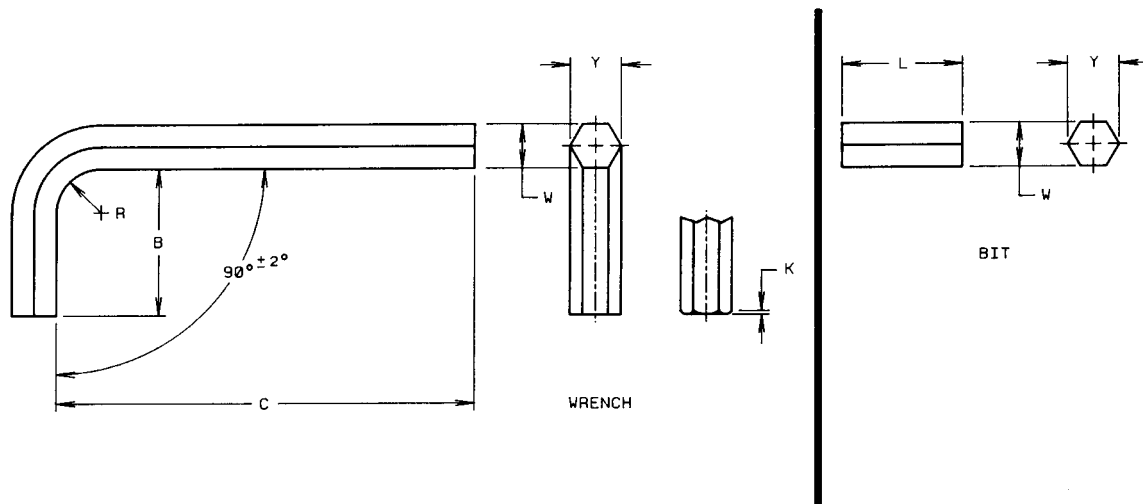

TABLE 48 DIMENSIONS (2)

NOMINAL WRENCH OR BIT SIZE	W		Y		B		C				R	L	K
	HEXAGON WIDTH ACROSS FLATS		HEXAGON WIDTH ACROSS CORNERS		LENGTH OF SHORT ARM		LENGTH OF LONG ARM				RADIUS OF BEND	LENGTH OF BIT	CHAMFER LENGTH
							SHORT SERIES		LONG SERIES				
	MAX.	MIN.	MAX.	MIN.	MAX.	MIN.	MAX.	MIN.	MAX.	MIN.	MIN.	± 1.5	MAX.
0.7	0.711	0.698	0.798	0.762	8	3	34	28	69	63	1.5	-	0.08
0.9	0.899	0.876	0.998	0.960	11	6	34	28	71	65	1.5	-	0.10
1.3	1.270	1.244	1.422	1.372	16	11	44	39	75	69	1.5	-	0.14
1.5	1.500	1.470	1.690	1.640	14	13	45	43	78	76	1.5	-	0.14
2	2.000	1.970	2.250	2.200	16	15	50	48	83	81	2.0	-	0.14
2.5	2.500	2.470	2.820	2.770	18	17	56	53	90	86	2.5	-	0.14
3	3.000	2.960	3.399	3.340	20	18	63	60	100	97	3.0	-	0.18
4	4.000	3.960	4.532	4.470	24	23	70	66	106	102	4.0	-	0.24
5	5.000	4.960	5.690	5.630	28	26	80	76	118	114	5.0	-	0.30
6	6.000	5.950	6.828	6.760	32	30	90	86	140	136	6.0	-	0.36
8	8.000	7.950	9.136	9.030	36	34	100	95	160	155	8.0	-	0.49
10	10.000	9.950	11.470	11.340	40	38	112	106	170	164	10.0	-	0.62
12	12.000	11.950	13.764	13.590	45	43	125	119	212	206	12.0	-	0.76
14	14.000	13.930	16.058	15.880	56	53	140	133	236	229	14.0	-	0.85
17	17.000	16.930	19.499	19.300	63	60	160	152	250	242	17.0	-	1.04
19	19.000	18.930	21.793	21.580	70	67	180	171	280	271	19.0	-	1.16
22	22.000	21.930	25.234	25.000	80	76	200	190	335	325	22.0	-	1.36
24	24.000	23.930	27.525	27.240	90	86	224	213	375	364	24.0	-	1.49
27	27.000	26.870	30.969	30.710	100	95	250	238	-	-	27.0	100.0	1.68
32	32.000	31.840	36.704	36.430	125	119	315	300	-	-	32.0	100.0	1.99
36	36.000	35.840	41.292	40.900	140	133	355	338	-	-	36.0	100.0	2.25

Bits smaller than 27mm are available, but lengths have not been standardized.

NOTES FOR TABLE 48

1. ENDS. Each end shall be perpendicular to the axis of the respective arms of the keys and the longitudinal axis of bits within 4° and the edges may be sharp, radiused or chamfered at the option of Holo-Krome, the chamfer not to exceed K.

2. ANGLE OF BEND. The angle of bend between the axis of the short arm and the axis of the long arm shall be 90°, ±2°.

3. PLATED PRODUCT. For plated wrenches and bits, all dimensions are before plating.

4. INTERCHANGEABILITY. The user is cautioned that ISO metric keys and bits of the same nominal size may not be able to perform adequately due to variations in size tolerances which may cause reaming. The use of Allen Metric Hexagon keys and bits is strongly recommended.

Applicable Standards and Specifications
ASME/ANSI B18.3.2M

TABLE 49 METRIC ALLEN SPLINE KEYS AND BITS

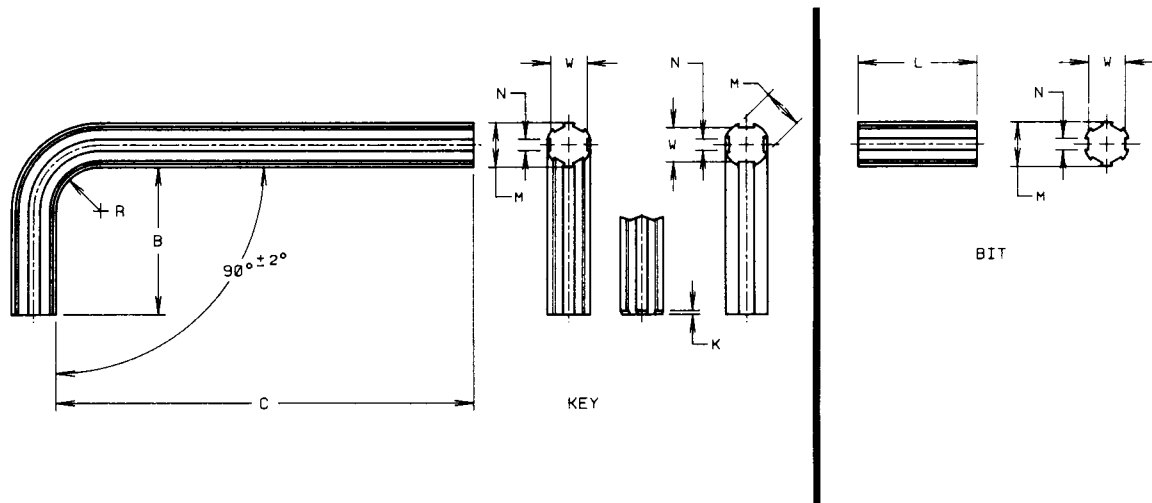

TABLE 49 DIMENSIONS (2)

NOMINAL KEY OR BIT SIZE	M		W		NO. OF SPLINES	N		B		C				R	K
	MAJOR DIAMETER		MINOR DIAMETER			WIDTH OF SPACE	LENGTH OF SHORT ARM		LENGTH OF LONG ARM				RADIUS OF BEND	CHAMFER	
	MAX.	MIN.	MAX.	MIN.			MAX.	MIN.	SHORT SERIES		LONG SERIES				
									MAX.	MIN.	MAX.	MIN.			
0.838	0.838	0.813	0.635	0.635	4	0.356	0.330	7.925	3.175	33.325	28.575	-	-	1.575	0.076
1.219	1.219	1.194	0.965	0.965	6	0.330	0.305	11.125	6.350	33.325	28.575	-	-	1.575	0.102
1.524	1.524	1.499	1.245	1.245	6	0.406	0.381	15.875	11.913	44.450	39.675	-	-	1.575	0.152
1.829	1.829	1.803	1.575	1.575	6	0.483	0.457	16.662	11.913	46.838	42.062	-	-	1.575	0.203
2.438	2.438	2.413	2.007	2.007	6	0.610	0.584	17.856	13.106	50.013	45.237	-	-	1.981	0.203
2.819	2.819	2.794	2.388	2.388	6	0.711	0.686	19.050	14.275	53.188	48.412	-	-	2.388	0.229
3.378	3.378	3.327	2.896	2.896	6	0.864	0.813	20.244	15.469	56.363	51.588	92.863	88.113	3.175	0.356
3.683	3.683	3.645	3.150	3.150	6	0.902	0.864	21.438	16.662	59.538	54.763	97.638	92.863	3.175	0.381
4.267	4.267	4.216	3.658	3.658	6	1.041	0.991	22.631	17.856	62.713	57.938	102.388	97.638	3.962	0.406
4.648	4.648	4.610	4.013	4.013	6	1.118	1.080	23.825	19.050	65.888	61.113	107.163	102.388	3.962	0.406
5.4686	5.4686	5.448	4.674	4.674	6	1.397	1.359	26.187	21.438	72.238	67.463	116.688	111.913	-	-
6.375	6.375	6.337	5.436	5.436	6	1.664	1.626	28.575	23.825	78.588	73.813	126.213	121.438	5.563	0.610
7.391	7.391	7.353	6.248	6.248	6	1.969	1.930	30.963	26.187	84.938	80.163	135.738	130.963	6.350	0.762
9.449	9.449	9.411	7.874	7.874	6	2.477	2.438	34.138	29.362	97.638	92.863	154.788	150.013	7.925	0.813
11.532	11.532	11.494	9.576	9.576	6	3.010	2.972	37.313	32.537	110.228	105.563	173.838	156.363	9.525	1.118
15.113	15.113	15.075	12.700	12.700	6	3.708	3.670	43.663	38.887	135.738	130.963	211.938	207.163	12.700	1.270
15.748	15.748	15.685	13.310	13.310	6	4.102	4.039	46.838	42.062	148.438	143.663	230.988	226.213	12.700	1.346
17.729	17.729	17.666	15.062	15.062	6	4.585	4.521	46.838	42.062	148.438	143.663	-	-	14.275	1.397
20.066	20.066	20.003	17.120	17.120	6	5.017	4.953	50.013	45.237	161.138	156.363	-	-	15.875	1.778

Bits are available, but lengths have not been standardized.

NOTES FOR TABLE 49

1. ENDS. Each end shall be perpendicular to the axis of the respective arms of the keys and the longitudinal axis of bits with 4° and the edges may be sharp, radiused, or chamfered at the option of Holo-Krome, the chamfer not to exceed K.

2. PLATED PRODUCT. For plated keys and bits, all dimensions are before plating.

3. SOFT CONVERSION. The spline keys and bits are soft conversions from the inch system, and are therefore interchangeable with Inch product.

TABLE 50 HOLO-KROME METRIC DOWEL PINS

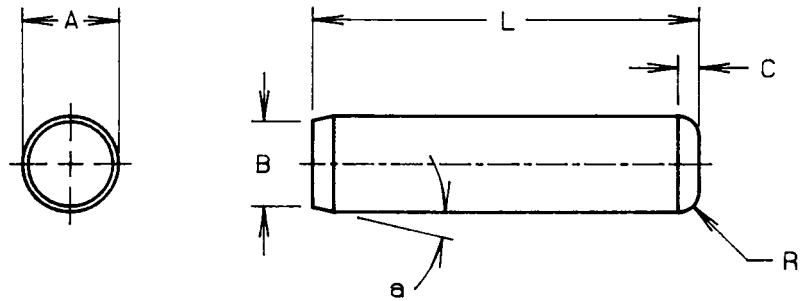

a = 4° - 8° for lengths L₁ and longer.
 a = 10° - 16° for lengths shorter than L₁.

TABLE 50 DIMENSIONS OF METRIC DOWEL PINS

NOMINAL SIZE OR NOMINAL PIN DIAMETER	A				B		C	R	L ₁
	PIN DIAMETER				POINT DIAMETER		CROWN HEIGHT	CROWN RADIUS	POINT ANGLE TRANSITION LENGTH
	STANDARD SERIES PINS		OVERSIZE SERIES PINS						
	MAX.	MIN.	MAX.	MIN.	MAX.	MIN.	MAX.	MIN.	NOM.
1.5	1.508	1.503	1.530	1.525	1.4	1.2	0.6	0.2	8
2	2.008	2.003	2.030	2.025	1.9	1.7	0.6	0.2	8
2.5	2.508	2.503	2.530	2.525	2.4	2.2	0.7	0.3	8
3	3.008	3.003	3.030	3.025	2.9	2.6	0.8	0.3	8
4	4.008	4.003	4.030	4.025	3.9	3.6	0.9	0.4	10
5	5.008	5.003	5.030	5.025	4.9	4.6	1.0	0.4	10
6	6.009	6.003	6.031	6.025	5.8	5.4	1.1	0.4	12
8	8.009	8.003	8.031	8.025	7.8	7.4	1.3	0.5	12
10	10.009	10.003	10.031	10.025	9.8	8.4	1.4	0.6	16
12	12.009	12.003	12.031	12.025	11.8	11.4	1.6	0.6	20
16	16.009	16.003	16.031	16.025	15.8	15.3	1.8	0.8	20
20	20.009	20.003	20.031	20.025	19.8	19.3	2.0	0.8	25
25	25.009	25.003	25.031	25.025	24.8	24.3	2.3	1.0	25

NOTES FOR TABLE 50

- POINT LENGTH.** The point length is decreased and the point angle increased on short dowel pins.
- EFFECTIVE LENGTH.** The effective length (that portion of the pin between the start of the point angle and the radius point of the crown) on short dowel pins shall not be less than 75% of the overall length of the pin. For short pins, it may be necessary to deviate from the specified dimensions by reducing the crown radius or height, and increasing the point angle, or both.
- STRAIGHTNESS.** Dowel pins shall be straight over the effective length within an accumulative total of 0.013mm per 25mm of length for nominal lengths up to and including 100, and within 0.05mm total for all nominal lengths above 100.
- END CONTOURS>** The ends of hardened ground dowel pins shall be essentially perpendicular to the axis of pin. One end of the pin shall be pointed and the other end crowned to the dimensions specified in Table 50. On the pointed end, the edge formed by the surface of point and the end of pin may be slightly rounded or broken. The center of the pointed end may be flat or concave. See Fig. 1. The crowned end shall be essentially flat to convex.
- POINT CONCENTRICITY.** The diameter of the point may be eccentric with the pin diameter to an extent such that the minimum length of point on the pin is no less than 0.1mm. See Fig. 1.

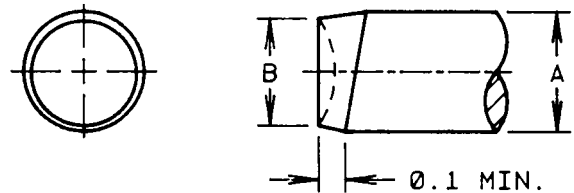

Applicable Standards and Specifications
 ASME B18.8.5M

TABLE 51 HOLO-KROME METRIC SCREW THREAD STANDARDS

Holo-Krome Metric Product is threaded to the requirements of ANSI/ASME B1.13M, Metric Screw Threads, M Profile, coarse series, with a Tolerance Class of 4g6g. Because of the lack of familiarity with the ISO system of tolerance designation, a summary is presented here.

METRIC THREAD DESIGNATIONS AND FITS

ISO Metric threads have a designation system which, like the Inch, provides the ability to define a class of fit to meet the degree of precision necessary to the joint.

The designation applies to both internal and external threads, and is designed to prevent the possibility of interference fit unless specifically

designated. Accommodation is provided to vary the amount of tolerance (tolerance grade) and the location of the tolerance starting position (allowance) for both the pitch diameter and the major diameter on external threads and the pitch diameter and the minor diameter on internal threads. The chart below illustrates these designations.

TOLERANCE GRADE AND TOLERANCE POSITION SYMBOLS USED TO DESIGNATE TOLERANCE CLASSES IN ISO METRIC THREADS.

AMOUNT	EXTERNAL THREADS		TOLERANCE POSITION (ALLOWANCE)	INTERNAL THREADS		TOLERANCE POSITION (ALLOWANCE)
	TOLERANCE GRADE (TOLERANCE)			TOLERANCE GRADE (TOLERANCE)		
	MAJOR DIAMETER	PITCH DIAMETER		MAJOR DIAMETER	PITCH DIAMETER	
0 Small ↓ Large	-	-	h	-	-	H
	-	-		-	-	
	4	4		4	4	
	-	-	g	5	5	G
	6	6		6	6	
	-	-		7	7	
8	8	8	8	-		
-	-	e	-			

To illustrate a complete designation, let us use the example M5 x 0.5 5g6g. This delineates a thread 5 millimeters in nominal diameter, with a pitch of 0.5. This is a fine thread, because a coarse thread (0.8) would be omitted from the designation. In other words, in common practice a coarse thread would be referred to as M5 - 5g6g.

The 5g represents the pitch diameter information - a tolerance grade of 5, which is fairly small, and a tolerance position of g, which indicates an allowance for plating has been built into the size. The 6g represents the same information for the major diameter - a somewhat larger tolerance but also with a plating allowance.

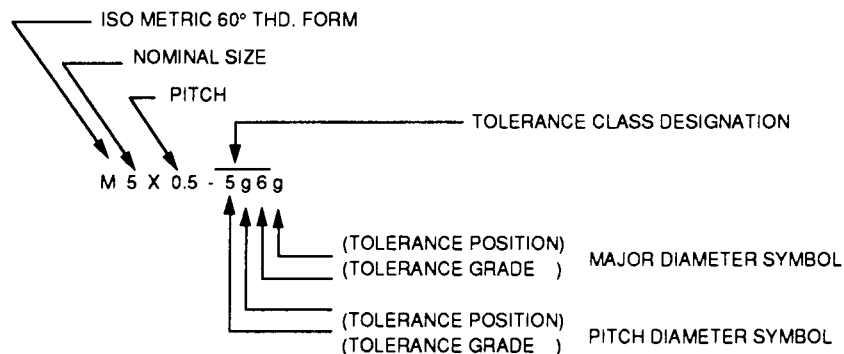

TABLE 52 EXTERNAL THREAD-LIMITING DIMENSIONS M PROFILE

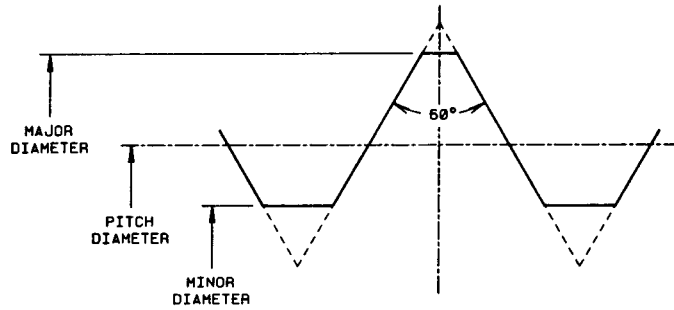
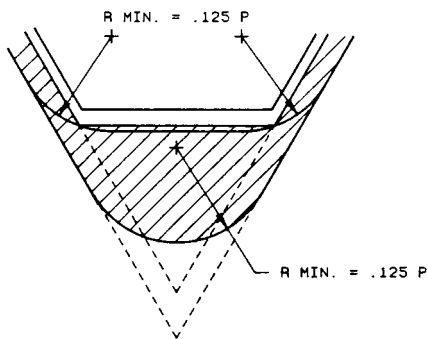

TABLE 52 EXTERNAL THREAD-LIMITING DIMENSIONS M PROFILE

BASIC THREAD DESIGNATION	TOLERANCE CLASS	ALLOWANCE, ES(2)	MAJOR DIAMETER, D		PITCH DIAMETER, D ₂		MINOR DIAM., D ₁ (FLAT FORM) MAX. TOL.	MINOR DIAM., D ₃ (ROUNDED FORM) MIN. (FOR REFERENCE)
			MAX.	MIN.	MAX.	MIN.		
M1.6 x 0.35	4g6g	0.019	1.581	1.496	1.354	0.040	1.202	1.098
M2 x 0.4	4g6g	0.019	1.981	1.886	1.721	0.042	1.548	1.433
M2.5 x 0.45	4g6g	0.020	2.480	2.380	2.188	0.045	1.993	1.866
M3 x 0.5	4g6g	0.020	2.874	2.874	2.655	0.048	2.439	2.299
M4 x 0.7	4g6g	0.022	3.838	3.838	3.523	0.056	3.220	3.036
M5 x 0.8	4g6g	0.024	4.826	4.826	4.456	0.060	4.110	3.904
M6 x 1	4g6g	0.026	5.794	5.794	5.324	0.071	4.891	4.637
M8 x 1.25	4g6g	0.028	7.760	7.760	7.160	0.075	6.619	6.315
M10 x 1.5	4g6g	0.032	9.732	9.732	8.994	0.085	8.344	7.985
M12 x 1.75	4g6g	0.034	11.701	11.701	10.829	0.095	10.072	9.656
M14 x 2	4g6g	0.038	13.682	13.682	12.663	0.100	11.797	11.331
M16 x 2	4g6g	0.038	15.682	15.682	14.663	0.100	13.797	13.331
M20 x 2.5	4g6g	0.042	19.623	19.623	18.334	0.106	17.252	16.688
M24 x 3	4g6g	0.048	23.577	23.577	22.003	0.125	20.704	20.030
M30 x 3.5	4g6g	0.053	29.522	29.522	27.674	0.132	26.158	25.386
M36 x 4	4g6g	0.060	35.465	35.465	33.342	0.140	31.610	30.738

Applicable Standards and Specifications
ANSI/ASME B1.13M, B1.3M



P	ROOT RADIUS 0.125P MIN.	P	ROOT RADIUS 0.125P MIN.
0.2	0.025	1.25	0.156
0.25	0.031	1.5	0.188
0.3	0.038	1.75	0.219
0.35	0.044	2	0.250
0.4	0.050	2.5	0.312
0.45	0.056	3	0.375
0.5	0.062	3.5	0.438
0.6	0.075	4	0.500
0.7	0.088	4.5	0.562
0.75	0.094	5	0.625
0.8	0.100	5.5	0.688
1	0.125	6	0.750
		8	1.000

TABLE 53 DIAMETER/THREAD PITCH COMPARISON

INCH SERIES

METRIC SERIES

SIZE	DIAMETER (IN.)	TPI	SIZE	DIAMETER (IN.)	PITCH (MM)	TPI (APPROX.)
			M1.4	0.055	0.3 0.2	85 127
#0	0.060	80				
			M1.6	0.063	0.35 0.2	74 127
#1	0.073	64 72				
			M2	0.079	0.4 0.25	64 101
#2	0.086	56 64				
			M2.5	0.098	0.45 0.35	56 74
#3	0.099	48 56				
#4	0.112	40 48				
			M3	0.118	0.5 0.35	51 74
#5	0.125	40 44				
#6	0.138	32 40				
			M4	0.157	0.7 0.5	36 51
#8	0.164	32 36				
#10	0.190	24 32				
			M5	0.196	0.8 0.5	32 51
			M6	0.236	1.0 0.75	25 34
1/4	0.250	20 28				
5/16	0.312	18 24				
			M8	0.315	1.25 1.0	20 25
3/8	0.375	16 24				
			M10	0.393	1.5 1.25	17 20
7/16	0.437	14 20				
			M12	0.472	1.75 1.25	14.5 20
1/2	0.500	13 20				
			M14	0.551	2 1.5	12.5 17
5/8	0.625	11 18				
			M16	0.630	2 1.5	12.5 17
			M18	0.709	2.5 1.5	10 17
3/4	0.750	10 16				
			M20	0.787	2.5 1.5	10 17
			M22	0.866	2.5 1.5	10 17
7/8	0.875	9 14				
			M24	0.945	3 2	8.5 12.5
1"	1.000	8 12				
			M27	1.063	3 2	8.5 12.5

**MECHANICAL PROPERTIES
AND
APPLICATION DATA
METRIC PRODUCT**

MECHANICAL PROPERTIES AND APPLICATION DATA, METRIC PRODUCT

MECHANICAL REQUIREMENTS

MATERIALS

Holo-Krome Metric socket products are made from Alloy Steel, containing one or more of the following alloying elements: chromium, nickel, molybdenum or vanadium in sufficient quantity to assure that the specified strength properties are met after oil quenching and tempering at an appropriate tempering temperature. The requirements for Class 12.9 in ASTM F-568 are applied, which is parallel to the ISO specification 898 Part I for strengths of fasteners.

HEAT TREATMENT PRACTICE

Holo-Krome Metric socket screw products are hardened and tempered in atmospherically controlled furnaces and quenched in oil above the specified minimum tempering temperature.

HEADING PRACTICE

Screws from M1.6 to M24 are normally Thermo-Forged® to insure proper grain flow and reduced internal stresses. Screws over M24 nominal size are hot formed.

THREADING PRACTICE

Standard metric socket head cap screws up to M36 can be rolled at Holo-Krome. For thread lengths longer than standard, or special thread pitches, the threads may be rolled or cut. Set screw threads may be rolled, cut or ground.

APPLICATION DATA

Standard Holo-Krome Metric alloy socket products are manufactured from alloy steels designed to obtain the optimum performance characteristics for each product.

Holo-Krome Metric socket screws are Thermo-Forged to insure optimum grain flow without causing fractures, bursts or strain-hardening of the parts. The forming process allows grain lines to flow through the part for greater part strength and head integrity. Socket walls are smooth and flat and the bottom of the socket does not have broaching chips that reduce socket depth and create a possible starting point for corrosion. Dimensional control is also easier to maintain.

WARNING

It is very important that the users of Socket Products, particularly Socket Head Cap Screws, be aware that the practice in Europe and other metric areas, is not to restrict the manufacture of these products to Property Class 12.9.

In the USA, and in inch module parts, it has been customary that the socket head cap screw configuration is always made from alloy steel and always to a high strength level, typically 180,000 psi. Metric countries produce this same configuration in alloy steels in Class 10.9 as well, and in Class 8.8 from carbon steel. It is vitally important that an assembly designed around Class 12.9 cap screws be put together with such screws. Beware of lower strength screws being substituted.

TABLE 54 METRIC SOCKET HEAD CAP SCREWS, MECHANICAL PROPERTIES

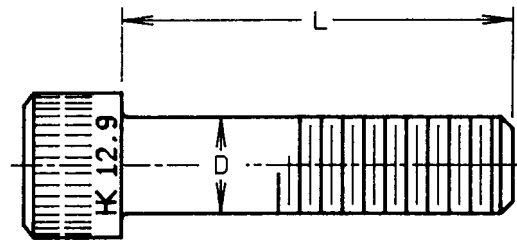

TABLE 54 TENSILE, YIELD, AND SHEAR STRENGTH OF METRIC SOCKET HEAD CAP SCREWS

NOMINAL SIZE AND THREAD PITCH	THREAD STRESS AREA	TENSILE STRENGTH	YIELD* STRENGTH	SINGLE SHEAR STRENGTH	
	(mm ²)	(kN)	(kN)	THD. SEC. (kN)	BODY SEC. (kN)
M1.6 x 0.35	1.27	1.55	1.40	0.96	1.22
M2 x 0.4	2.07	2.53	2.28	1.57	1.99
M2.5 x 0.45	3.39	4.14	3.73	2.57	3.29
M3 x 0.5	5.03	6.14	5.53	3.81	4.70
M4 x 0.7	8.78	10.7	9.63	6.63	8.39
M5 x 0.8	14.2	17.3	15.6	10.7	13.4
M6 x 1	20.1	24.5	22.1	15.2	19.5
M8 x 1.25	36.6	44.6	40.1	27.7	34.8
M10 x 1.5	58.0	70.8	63.7	43.9	55.0
M12 x 1.75	84.3	103	92.7	63.9	79.1
M14 x 2	115	140	126	86.8	108
M16 x 2	157	192	173	119	142
M20 x 2.5	245	299	269	185	222
M24 x 3	353	431	388	267	327
M30 x 3.5	561	684	616	424	506
M36 x 4	817	997	897	618	729

*Determined on machined specimens only

NOTES FOR TABLE 54

The Mechanical Properties listed are for standard metric screws tested at room temperature. In applications where the temperatures are considerably above or below room temperature the effect of the temperature on the properties of the screw must be considered. Short time tensile, creep and stress relaxation should be considered for applications where the temperature exceeds 200° C. Lower ductility, impact strength and fatigue life must be considered for screws subject to temperatures below -29° C.

The materials and heat treatment used for standard Metric Holo-Krome Alloy Steel Socket Products were selected to provide products that would have optimum tensile, impact and fatigue strengths. These materials and heat treatments also meet the requirements of both the USA and ISO specifications for metric products.

Applicable Standards and Specifications
ASTM A 574M

TABLE 55 METRIC SOCKET HEAD CAP SCREWS, TORQUE DATA

TABLE 55 TIGHTENING TORQUE DATA

NOMINAL SIZE AND THREAD PITCH	TENSION INDUCED, (kN)	RECOMMENDED TIGHTENING TORQUE (N•m)
M1.6	0.95	0.34
M2	1.50	0.69
M2.5	2.49	1.43
M3	3.59	2.48
M4	6.36	5.85
M5	10.4	12.0
M6	14.7	20.3
M8	26.5	48.8
M10	42.4	97.5
M12	59.8	165
M14	82.3	265
M16	112	413
M20	179	825
M24	258	1425
M30	402	2775
M36	589	4875

NOTES FOR TABLE 55

These are average values for standard Holo-Krome Metric Socket Head Cap Screws, with standard black finish, tested with hardened steel plates and hardened nuts, with the threads and bearing areas lubricated with plain, medium viscosity machine oil.

The relationship between the torque and the induced tension or preload, can be expressed by the empirical formula $T=KDP$, in which T is the tightening torque in Newton-meters, D is the diameter of the screw in mm, P is the tension in kiloNewtons and K is the torque coefficient. The torque coefficient is not constant, but varies with the material, surface finish and lubricity of the threads and head bearing surface of the screw and the parts being tightened.

For the condition shown above (standard alloy steel black finished screws clamping hardened steel parts), K will range from 0.19 to 0.25. For cadmium plated screws with steel parts, K will usually fall between 0.13 and 0.17. For zinc plated screws, K may fall between 0.30 and 0.34. When the thread and head bearing surfaces are covered with certain types of lubricants, or with anti-seize compounds, K can drop to as low as 0.05. At the other extreme, combinations of certain materials, such as austenitic stainless steel screws and unlubricated parts, can result in K values above 0.35.

Because the induced tension can vary considerably from one type of assembly to another, the above data must be used with caution, particularly in applications where the control of preload is critical and must be obtained by Torque Wrench method. For such applications, the relationship between torque and induced load should be determined experimen-

tally for the actual parts and lubrication practice used.

TIGHTENING TORQUES. At the recommended tightening torques listed, standard Holo-Krome Metric Socket Head Cap Screws, used under the conditions described, will be preloaded to approximately 75% of the tension induced at yield. The bearing stress under the head will be approximately 530 MPa, so indentation should not occur when the clamped parts are made of steel or cast iron with a hardness equal to or greater than HRB 85. With softer materials, washers may be required under the heads of the screws to prevent indentation.

In applications where screws are subject to fatigue from dynamic loading, the importance of proper preloading during assembly can not be over-emphasized. The proper preload is especially important for rigid type (metal-to-metal) joints where it has been found that the use of preload greater than the dynamic external load will usually eliminate the probability of fatigue failure. For this reason, the preferred practice for such assemblies is to preload to 75% of the induced tension at yield.

For flexible type joints, however, and for assemblies exposed to elevated temperatures, much lower preloads may be required. No general recommendations are possible for the wide range of applications and service conditions. Each application must be analyzed individually, because the preload requirements may vary considerably from one application to another. Users who desire suggestions for the preload or tightening torque to be used for a specific application are invited to contact the Holo-Krome Engineering Department.

TABLE 56 DECARBURIZATION AND DISCONTINUITY LIMITS

CARBURIZATION OR DECARBURIZATION

Surface carbon content variations conform to the limits specified in Table when tested in accordance with ASTM A 574M. There should be no complete decarburization nor carburization. Carburization or decarburization can only be measured accurately on a screw that has been sectioned on a plane that is parallel to and passes through the screw axis.

DISCONTINUITIES

SOCKET DISCONTINUITIES

Discontinuities in the socket area allowed to a maximum depth of 0.03D or 0.13 mm (whichever is greater), providing they do not affect the usability and performance of the screw.

Longitudinal discontinuities must not exceed .25T in length. Permissible and nonpermissible discontinuities are shown in Figure 1.

PERMISSIBLE HEAD AND SHANK DISCONTINUITIES

Discontinuities as defined above are permitted in the location illustrated in Figure 1 to the depths described above, with the addition that peripheral discontinuities are permitted a maximum depth = .06D, but not over 1.6mm. These discontinuities are permitted providing they do not affect the usability and performance of the screw. All discontinuities are measured perpendicular to the indicated surface.

When the engineering requirements of the application require that surface discontinuities must be more closely controlled, the purchaser should specify the applicable limits in the original inquiry and in the purchase order.

REJECTION

Rejections should be reported to Holo-Krome within 30 days of receipt of the parts, by the purchaser. The rejection may be in writing to the distributor or directly to the Holo-Krome Sales Department. When no special requirements are specified, industry standards such as ASTM A574M will be used as referee documents.

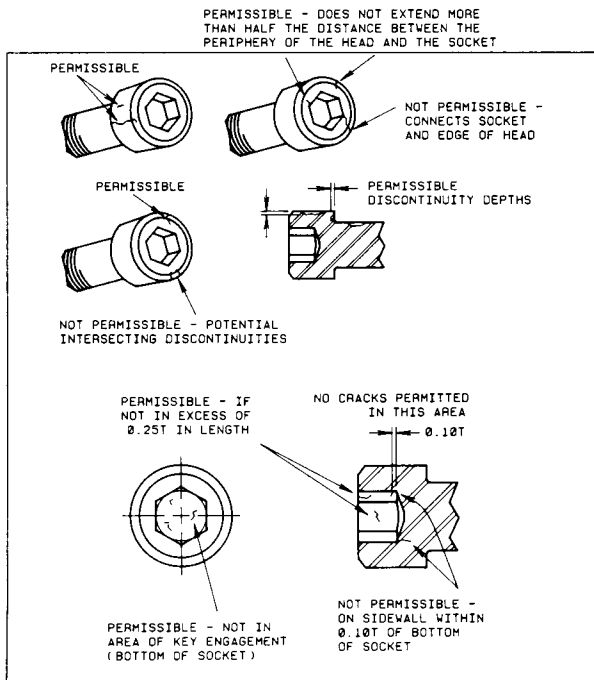
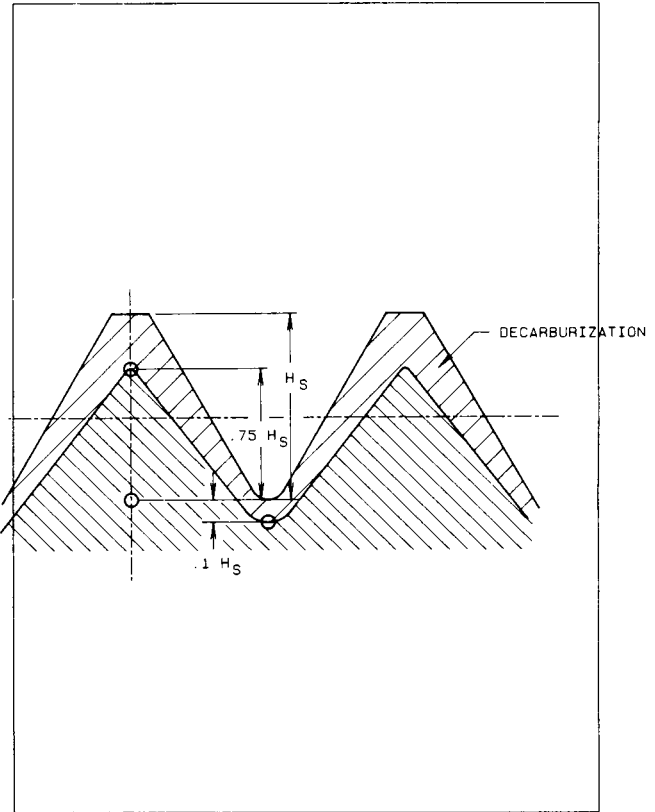

FIGURE 1

T = KEY ENGAGEMENT

TABLE 56 DECARBURIZATION LIMITS

THREAD PITCH mm	THREAD HEIGHT H, mm	0.75 H, FROM ROOT TO CREST, MIN. mm
0.35	0.215	0.161
0.4	0.245	0.184
0.45	0.276	0.207
0.5	0.307	0.230
0.7	0.429	0.322
0.8	0.491	0.368
1.0	0.613	0.460
1.25	0.767	0.575
1.5	0.920	0.690
1.75	1.074	0.806
2	1.227	0.920
2.5	1.534	1.151
3	1.840	1.380
3.5	2.147	1.610
4	2.454	1.841

TABLE 57 HOLO-KROME STAINLESS STEEL METRIC SOCKET HEAD CAP SCREWS

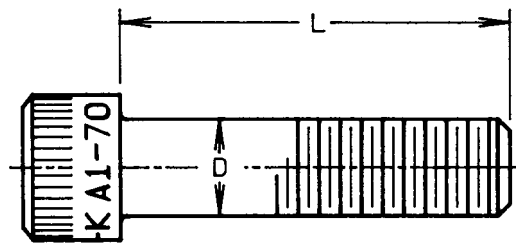

MATERIAL

Standard Holo-Krome Stainless Steel Metric Socket Head cap screws are made from austenitic (18-8) stainless steel. They withstand all ordinary rusting, are immune to all foodstuffs, sterilizing solutions, most of the inorganic chemicals, dyestuffs and a wide variety of inorganic chemicals. They resist nitric acid well, halogen acids poorly and sulfuric acids moderately.

Holo-Krome Stainless Steel Cap Screws are passivated by immersion in a nitric acid bath subsequent to the last manufacturing operation. This rids the surface of contaminants picked up during fabrication that can cause surface staining or rusting.

Holo-Krome Standard Stainless Steel Cap Screws have low magnetic permeability which makes them suitable for electrical applications where non-magnetic parts are required.

TABLE 57 MECHANICAL PROPERTIES OF THREADED TO THE HEAD STAINLESS STEEL METRIC SOCKET HEAD CAP SCREWS

NOMINAL SIZE AND THREAD PITCH	TENSILE STRENGTH	YIELD STRENGTH*	SINGLE SHEAR STRENGTH	TIGHTENING TORQUE
	(kN)	(kN)	THREAD SEC. (kN)	(N-m)
M1.6 x 0.35	.84	.58*	0.55	0.18
M2 x 0.4	1.38	.83*	0.90	0.37
M2.5 x 0.45	2.25	1.37*	1.47	0.76
M3 x 0.5	3.35	2.01*	2.19	1.31
M4 x 0.7	5.84	3.51*	3.80	3.10
M5 x 0.8	9.44	5.68*	6.14	6.36
M6 x 1	13.4	8.04	8.72	10.8
M8 x 1.25	24.3	14.6	15.9	25.9
M10 x 1.5	38.6	23.2	25.2	51.7
M12 x 1.75	56.1	33.7	36.7	87.5

*Yield strength for information only-sizes through M5 are tested for torsional strength only per ASTM F738. Values based on ASTM F837M.

NOTES FOR TABLE 57

Tensile strengths given above are for standard stainless steel metric socket head cap screws tested at room temperatures. When screws are to be exposed to higher temperatures the effect of temperature upon the short time properties and the possibility of plastic deformation, or creep, should be considered. At 425°C, the tensile strength of standard stainless steel screws will be approximately 75% of the room temperature strength, and the screws have good creep resistance. Normally, standard stainless steel screws are not used above 425°C, because above this temperature

the material is subject to intergranular corrosion.

The property class designation for Holo-Krome Stainless Steel Metric Cap Screws is A1-70, as defined by ASTM F738.

Applicable Standards and Specifications
ASTM F837M

TABLE 58 HOLO-KROME METRIC BUTTON HEAD AND FLAT COUNTERSUNK HEAD SOCKET CAP SCREWS

MECHANICAL PROPERTIES

Standard Metric Holo-Krome Alloy Steel Button and Flat Countersunk Head Cap Screws are manufactured from Holo-Krome analysis high grade alloy steel, hardened and tempered to provide the following mechanical properties.

The tensile strength of the screws, because of head configuration are based on 980 MPa as shown in ASTM F 835M.

Tensile Strength * 1220 MPa
 Yield Strength* 1100 MPa
 Elongation in 2 inches* 8%
 Reduction of Area* 35%
 Hardness 38 Rockwell C min.
 *Apply to cylindrical test specimens only.

TABLE 58 HOLO-KROME METRIC BUTTON HEAD AND FLAT COUNTERSUNK HEAD SOCKET CAP SCREWS

NOMINAL SIZE AND THREAD PITCH MM	THREAD STRESS AREA (mm ²)	TENSILE STRENGTH (kN)	SINGLE SHEAR STRENGTH (THREAD SEC.) (kN)
M3 x 0.5	5.03	4.93	3.81
M4 x 0.7	8.78	8.60	6.65
M5 x 0.8	14.2	13.9	10.7
M6 x 1	20.1	19.7	15.2
M8 x 1.25	36.6	35.9	27.7
M10 x 1.5	58.0	56.8	43.9
M12 x 1.75	84.3	82.6	63.9
M16 x 2	157	155	119
M20 x 2.5	245	240	185

NOTES FOR TABLE 58

BUTTON HEAD CAP SCREWS ARE DESIGNED FOR LIGHT FASTENING APPLICATIONS ONLY, SUCH AS SHEETMETAL COVERS, PLASTIC GUARDS, ETC. THEY SHOULD NOT BE USED IN CRITICAL HIGH STRENGTH APPLICATIONS WHERE SOCKET HEAD CAP SCREWS SHOULD BE USED.

The mechanical properties listed are for screws tested at normal room temperatures. In applications where the temperature are considerably

above or below room temperature the effect of the temperature on the screw strength must be considered. Short time tensile, creep and stress relaxation should be considered for applications where the temperature exceeds 204° C. Lower ductility, impact strength and fatigue life must be considered for screws subject to temperatures below -29° C.

Applicable Standards and Specifications
 ASTM F 835M

TABLE 59 TIGHTENING TORQUE - N•m

NOMINAL SIZE AND THREAD PITCH MM	BUTTON HEAD		FLAT COUNTERSUNK HEAD
	HEX KEY SIZE (mm)	MAX. TIGHTENING TORQUE (N•m)	MAX. TIGHTENING TORQUE (N•m)
M3 x 0.5	2	1.25	1.85
M4 x 0.7	2.5	2.9	3.4
M5 x 0.8	3	5.9	6.9
M6 x 1	4	10	12
M8 x 1.25	5	24	28
M10 x 1.5	6	48	56
M12 x 1.75	8	84	99
M16 x 2	10	207	246
M20 x 2.5	12		400

Torque to tighten screw with key, not by turning nut.

These torques apply to standard black screws in rigid joints, when torqued with standard hex keys or bits.

TABLE 60 HOLO-KROME METRIC SHOULDER SCREWS

SHOULDER SCREWS

Shoulder screws, commonly referred to as stripper bolts, are used in a variety of applications. In die sets, they can be used for stripper springs and as guides. They are used as pivots for linkages, pulleys and sprockets and as hinges.

Holo-Krome metric socket shoulder screws are made from alloy steel. Holo-Krome step grinds the shoulder and roll thread diameter in one operation after heat treatment to assure concentricity.

MECHANICAL PROPERTIES

Tensile Strength 1100 MPa*
 Hardness 36 Rockwell C min
 *Based on stress area of the thread neck.

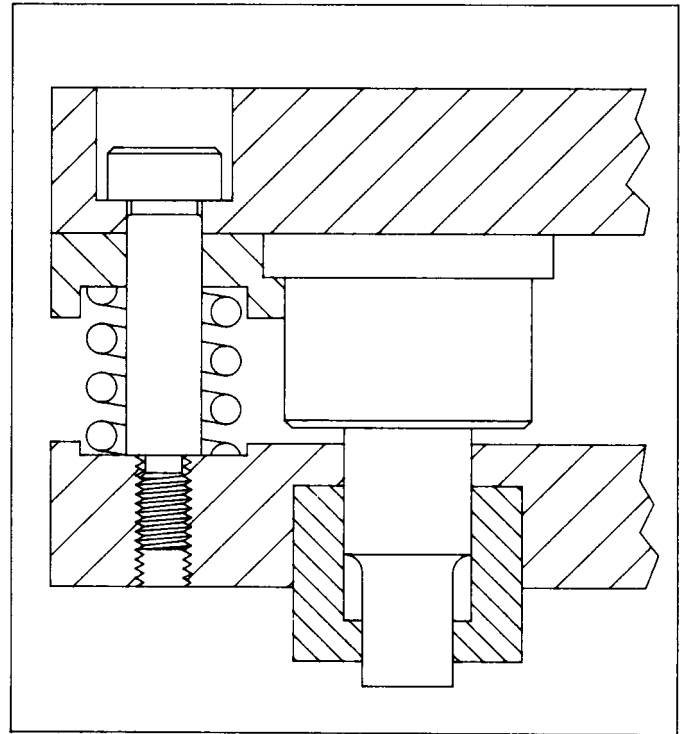

TABLE 60 MECHANICAL PROPERTIES

NOMINAL SHOULDER DIAMETER (mm)	NOMINAL THREAD SIZE (MM)	THREAD NECK SECTION TENSILE STRENGTH (kN)	SINGLE SHEAR STRENGTH (kN)		HEX KEY SIZE (mm)	TIGHTENING TORQUE** (Nm)
			THREAD NECK	SHOULDER		
6.5	M5 x 0.8	11.7	7.0	21.6	3	6.9
8	M6 x 1	15.2	10.0	32.7	4	12
10	M8 x 1.25	28.6	18.9	51.3	5	28
13	M10 x 1.5	51.1	30.7	86.8	6	56
16	M12 x 1.75	75.5	45.3	13.1	8	99
20	M16 x 2	145	87.1	206	10	250
25	M20 x 2.5	230	137	322	12	400

** It is recommended that tightening torque be limited to these values when screws are to be tightened or loosened with standard keys or bits.

TABLE 61 HOLO-KROME METRIC SOCKET SET SCREWS - AXIAL HOLDING POWER

AXIAL HOLDING POWER OF CUP POINT SET SCREWS (ALLOY STEEL)

NOMINAL SIZE (mm)	HEX KEY SIZE (mm)	TIGHTENING TORQUE (N•m)	AXIAL HOLDING POWER (N)
1.6	.7	0.1	44
2	.9	0.2	87
2.5	1.3	0.6	306
3	1.5	1.0	880
4	2.0	2.1	1570
5	2.5	4.7	2400
6	3.0	7.7	3380
8	4.0	17.8	5800
10	5.0	35	9360
12	6.0	55	13,300
16	8.0	125	23,100
20	10.0	250	34,700
24	12.0	425	51,500

NOTE:

The values above have been developed experimentally by assembling steel collars to cold finished steel bars (Rockwell B 80-100) with standard Holo-Krome Metric alloy steel Cup Point Set Screws with the black finish. The set screws were all as long as or longer than their nominal diameter. The axial holding power listed above was the average force required to cause .125 mm movement of the collar along the shaft after tightening the set screw to the listed torque. For specific applications, values may vary as much as ±30 percent from values shown.

Giving a cup point a relative holding power of 1, the holding power of a cone point is 1.07, a flat point or dog point 0.92 and an oval point 0.9.

For torsional holding power, multiply the axial holding power value by the shaft radius.

SET SCREW HOLDING POWER

FIG. A.

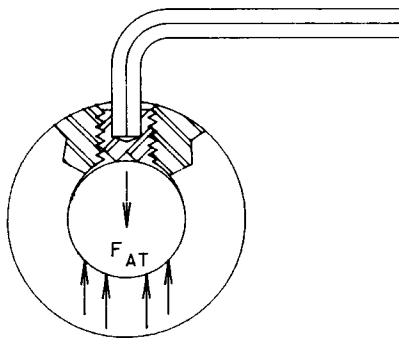

AXIAL THRUST = F_{AT}

FIG. B

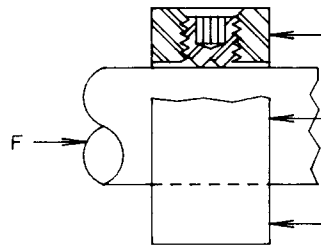

AXIAL HOLDING POWER = F

FIG. C

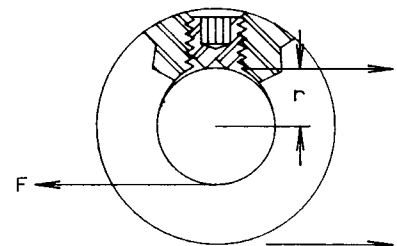

TORSIONAL HOLDING POWER
 $T = Fr$

Applicable Standards and Specifications

ASTM F 912M

INTRODUCTION. Set screws, unlike most other fasteners, are basically compression fasteners. Because studies made of tension fasteners do not apply and because of the complex nature of this type of joint, the holding power of a set screw is more difficult to predict and control than the typical cap screw joint. Many variables introduced by a particular application may affect the holding power performance of a set screw. It is therefore important for the designer to understand set screw holding power and the nature of the variables involved when designing a set screw joint.

HOLDING POWER. The forces which a set screw assembled joint can transmit or withstand without relative displacement of the two parts is a measure of the holding power of the screw. This holding power can best be described in terms of the forces acting to cause relative

movement between the assembled parts.

1. **AXIAL HOLDING POWER.** Using a simple shaft collar application as an illustration, the force acting on the collar to move it along the shaft is called the axial force. The ability of the set screw to withstand this force without relative displacement is called its Axial Holding Power.

2. **TORSIONAL HOLDING POWER.** Using a shaft pulley or gear application as an example, the force (F) acting to rotate or slip the pulley around the shaft is frequently called the rotational force. The ability of a set screw to withstand these forces tending to rotate the part on the shaft without relative movement of the two parts is called its Torsional Holding Power.

NOTE. For further discussion of holding power see page 38.

TABLE 62 METRIC ALLEN WRENCHES AND BITS

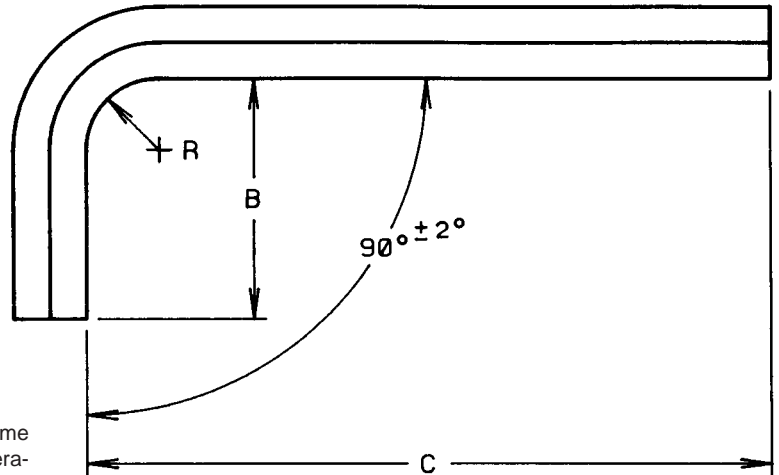

MECHANICAL PROPERTIES

Standard Allen Wrenches and Bits are manufactured from Holo-Krome Alloy Steel, hardened by quenching in oil from the hardening temperature and tempered to a hardness range of HRC 50-57 for keys 2.5mm to 12mm, HRC 45-53 for 14mm and larger, and Knoop 565-685 for sizes 2mm and smaller, to provide the following torsional properties.

TABLE 62 METRIC ALLEN WRENCHES

MECHANICAL

NOMINAL SIZE mm	TORQUE RATING (Nm)
0.7	0.1
0.9	0.2
1.3	0.6
1.5	1.0
2	2.1
2.5	4.7
3	7.7
4	17.8
5	35
6	57
8	126
10	252
12	420
14	670
17	1180
19	1670
22	2450
24	3200
27	4300
32	6800
36	10,000

APPLICATION DATA

NOMINAL SIZE mm	CAP SCREWS	FLAT COUNTERSUNK HEAD CAP SCREWS	BUTTON HEAD CAP SCREWS	SHOULDER SCREWS	SET SCREWS
		NOMINAL SCREW SIZES			
0.7	—	—	—	—	M1.6
0.9	—	—	—	—	M2
1.3	—	—	—	—	M2.5
1.5	M1.6	—	—	—	M3
2	M2.5	M3	M3	—	M4
2.5	M3	M4	M4	—	M5
3	M4	M5	M5	6.5	M6
4	M5	M6	M6	8	M8
5	M6	M8	M8	10	M10
6	M8	M10	M10	13	M12
8	M10	M12	M12	16	M16
10	M12	M16	M16	20	M20
12	M14	M20	—	25	M24
14	M16	—	—	—	—
17	M20	—	—	—	—
19	M24	—	—	—	—
22	M30	—	—	—	—
24	—	—	—	—	—
27	M36	—	—	—	—

TORQUE RATING-Standard Allen Wrenches cut into bits for use in torque wrenches will transmit the above torques. These torque values are 90% of average torque required to develop a permanent visible twist in bits which have 25mm of hexagon exposed between the torque wrench and the socket. These are also the torque values which keys transmit when the short arm is inserted in a socket and the long arm is

deflected or bent through an angle of 25 to 30° by the application of force near the end of the long arm.

Applicable Standards and Specifications
ASME/ANSI B18.3.2M

TABLE 63 HOLO-KROME METRIC DOWEL PINS

MECHANICAL PROPERTIES

Standard Holo-Krome Metric Dowel Pins are manufactured from Holo-Krome analysis High Grade Alloy Steels heat treated to a core hardness of HRC 47-58 for toughness and strength and a surface hardness of HRC 60 minimum for wear resistance.

CAUTION: Holo-Krome recommends dowel pins be inserted by application of a constant pressure, with the pin being shielded in case of fracture. A striking force can cause the pin to shatter.



TABLE 63 HOLO-KROME METRIC DOWEL PINS

NOMINAL SIZE mm	MINIMUM CASE DEPTH mm	SINGLE SHEAR STRENGTH (kN)	DOUBLE SHEAR STRENGTH (kN)	RECOMMENDED HOLE SIZE mm	
				MAX.	MIN.
1.5	0.25	1.85	3.7	1.500	1.487
2.0	0.25	3.3	6.6	2.000	1.987
2.5	0.25	5.15	10.3	2.500	2.487
3.0	0.25	7.4	14.8	3.000	2.987
4.0	0.25	13.2	26.4	4.000	3.987
5.0	0.38	20.6	41.2	5.000	4.987
6.0	0.38	29.7	59.4	6.000	5.987
8.0	0.38	52.5	105	8.000	7.987
10.0	0.38	82.5	165	10.000	9.987
12.0	0.38	119	238	12.000	11.987
16.0	0.38	211	422	16.000	15.987
20.0	0.38	330	660	20.000	19.987
25.0	0.38	515	1030	25.000	24.987

